

Maintenance for HV and Auxiliary Batteries

Service Category General

Section Maintenance

Market USA

Lexus Supports
ASE Certification 

Applicability

YEAR(S)	MODEL(S)	ADDITIONAL INFORMATION
2018 - 2019	ES300H, LC500H, LS500H, NX300H, RX450H	
2018	GS450H	

REVISION NOTICE

May 10, 2018 Rev1:

- **Applicability has been updated to include 2019 model year vehicles. Any previous printed versions of this bulletin should be discarded.**

Introduction

Hybrid vehicles are equipped with two types of batteries:

- Hybrid Vehicle (HV) battery
- Auxiliary (12V) battery

If the vehicle is put into storage, the State-Of-Charge (SOC) of its HV battery and auxiliary battery will gradually decrease. To prevent the auxiliary battery from becoming discharged during storage, proper maintenance is necessary.

Perform the following maintenance service for the HV battery and 12V auxiliary battery.

NOTE

- Before disconnecting the auxiliary battery, confirm the shift lever is in the "P" position and apply the parking brake completely. The shift lever cannot be shifted from the "P" position with the 12V auxiliary battery disconnected.
- If the negative (–) terminal of the auxiliary battery is reconnected, even if the power switch is selected to the Start mode, the hybrid system may not start. In this case, push the Power switch to select Start again to start the hybrid system (the Ready light is ON). If the hybrid system still does not start (the Ready light is OFF), refer to the Repair Manual.
- If the vehicle is equipped with VGRS, the system must be initialized after the auxiliary battery has been reconnected. Refer to the applicable Service Bulletin for instructions.

Maintenance for HV and Auxiliary Batteries

Maintenance Items

CONDITION*	MAINTENANCE OPERATION
Before Delivery	Fully charge the 12V auxiliary battery. Fast charge is NOT recommended on the 12V battery in order to prevent battery damage. (Deliver the vehicle to the customer after it is fully charged to 12.6V.)
To Store for 30 Days or More	Disconnect the negative (-) terminal of the 12V auxiliary battery to prevent the SOC of the auxiliary battery from decreasing during storage due to parasitic current.
Just After Unloading and Every 2 Months	Keep the Hybrid System ON for 30 minutes with the transmission in the "P" position (in order to charge the HV battery and the auxiliary battery).

*The condition also corresponds with the section titles in this Service Bulletin.

Warranty Information

OP CODE	DESCRIPTION	TIME	OFF	T1	T2
N/A	Not Applicable to Warranty	-	-	-	-

Required Tools & Equipment

SPECIAL SERVICE TOOLS (SST)	PART NUMBER	QTY
GR8 Battery Diagnostic Station*	00002-MCGR8	1

* Essential SST.

NOTE

Additional SSTs may be ordered by calling 1-800-933-8335.

Before Delivery

1. BEFORE charging the auxiliary battery, turn OFF ALL lights and accessories.
2. Locate the 12V auxiliary battery.

Maintenance for HV and Auxiliary Batteries

Before Delivery (continued)

3. Remove the positive (+) terminal cover.

Figure 1.

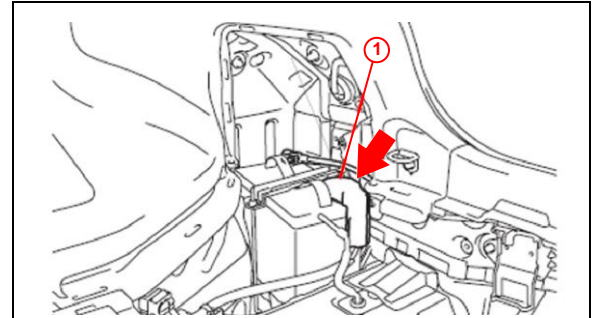

1	Positive (+) Terminal Cover
----------	------------------------------------

4. Check the battery SOC.
 - If the battery voltage is **LESS THAN** 12.6V, continue to step 5.
 - If the battery voltage is 12.6V or **MORE**, replace the positive (+) terminal, close the battery cover, install the luggage compartment floor mat, and close the trunk.

CAUTION

If measuring the voltage with the negative (–) terminal connected, verify IG/OFF, and turn the headlights ON for 60 seconds or more. This will remove the surface charge.

5. Test the 12V auxiliary battery using the GR8 Battery Diagnostic Station.

If charging is required, the GR8 will automatically start to charge.

- A. Connect the red charger clamp to the positive (+) battery terminal and the black charger clamp to the negative (–) battery terminal.
- B. Plug the charger into a grounded 110V outlet and flip the power switch to the ON position.

Figure 2. GR8 Battery Diagnostic Station

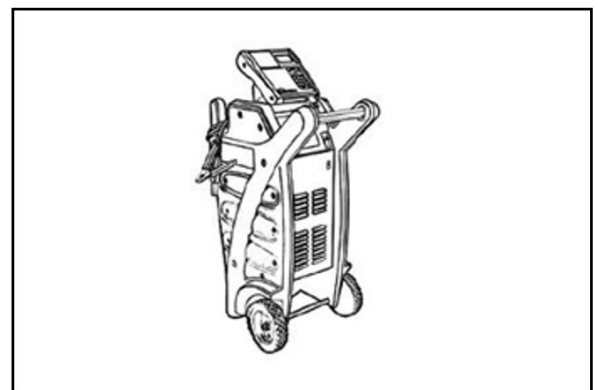

Maintenance for HV and Auxiliary Batteries

Before Delivery (continued)

- C. Once the charger is properly turned ON, perform a diagnostic charge (make sure to select the appropriate vehicle model). The GR8 Battery Diagnostic Station will indicate results when complete. If the battery tests bad (“Replace Battery”), replace the auxiliary battery.

NOTE

- If the vehicle model is NOT listed in the model list, charge by battery stock code. To charge by stock code, refer to the Lexus Battery Stock Number Chart located on *TIS – Diagnostics – Tools & Equipment – Battery Diagnostics*.
- If the auxiliary battery was stored at 32°F (0°C) or below, charge the auxiliary battery in a room above 32°F (0°C).

CAUTION

- **Charge in a well-ventilated area.**
- **Do NOT allow sparks or fire near the auxiliary battery.**

6. If the GR8 Battery Diagnostic Station is NOT available, you may charge the 12V battery by turning the vehicle to Ready ON.
- Run time will vary depending on the SOC.
 - If this method is used, you MUST confirm that the battery is charged to 12.8V using a DVOM.

To Store for 30 Days or More

Disconnect the Negative (–) Terminal:

1. Turn OFF ALL lights and accessories.
2. Disconnect the negative (–) terminal.

NOTE

When it is necessary to move the vehicle, reconnect the negative (–) terminal.

Figure 3.

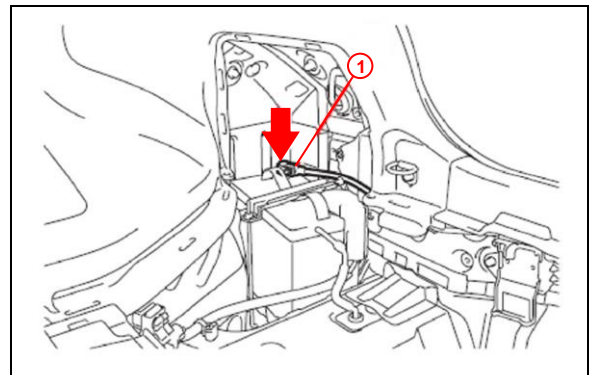

1 Negative (–) Terminal Cover

Maintenance for HV and Auxiliary Batteries

Every Two Months

Cycle Vehicle to Ready ON:

NOTE

- When the remaining capacity of the HV battery is low, the gasoline engine automatically starts and the HV battery is charged. The 12V auxiliary battery is also charged by the HV battery regardless of the gasoline engine operation.
- Make sure to reconnect the negative (-) terminal of the auxiliary battery BEFORE performing this procedure.

1. Park the vehicle in open air, or connect the exhaust extraction hose to the exhaust pipe.
2. Apply the parking brake.
3. With the brake pedal depressed, push the Power switch and check that the Ready light in the meter illuminates when the hybrid system starts (the Ready light is ON).

Figure 4.

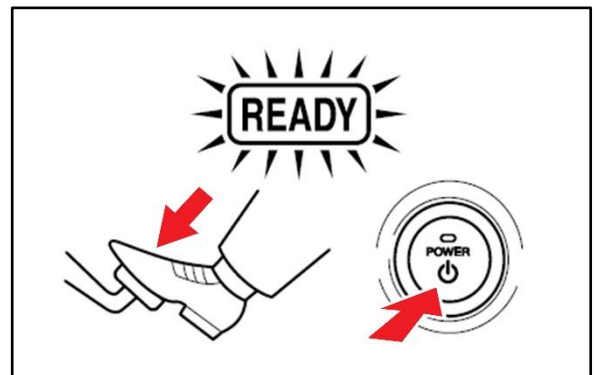

4. Turn OFF ALL lights and accessories.
5. Check that the shift lever is in the “P” position.

Maintenance for HV and Auxiliary Batteries

Every Two Months (continued)

Cycle Vehicle to Ready ON:

- Keep the Ready light ON and charge the HV battery for 30 minutes.

NOTE

- If the amount of charging energy is small, the display may NOT indicate the energy flow.
- Ensure there is a sufficient amount of fuel for the vehicle to run for 30 minutes.

Figure 5.

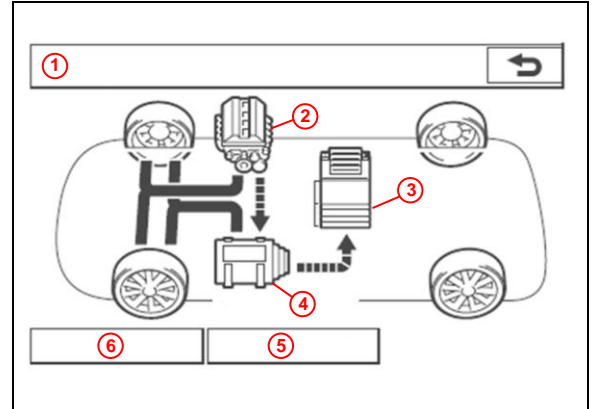

1	Energy Monitor
2	Engine
3	Battery
4	Electric Motor
5	Past Record
6	Consumption