

- ATTENTION:**
- GENERAL MANAGER
 - PARTS MANAGER
 - CLAIMS PERSONNEL
 - SERVICE MANAGER

IMPORTANT - All Service Personnel Should Read and Initial in the boxes provided, right.

© 2018 Subaru of America, Inc. All rights reserved.



QUALITY DRIVEN® SERVICE

SERVICE BULLETIN

APPLICABILITY: 2015-2016MY Impreza 4-Door
2015-2018MY WRX

NUMBER: 12-241-18

DATE: 05-10-18

SUBJECT: Trunk Lid Lock Assembly Interchangeability Information

INTRODUCTION:

This bulletin announces a change made to the trunk lid lock (latch) assembly. The purpose of this change is to improve parts integration (or “commonality”) between models. This change is not intended to address any specific customer concern. The Owner’s Manuals are currently being revised with the new part images.

PRODUCTION CHANGE INFORMATION:

The new “T-Handle” style trunk lid lock was incorporated into production starting with VIN **F9828714**.

PART INFORMATION:

The new “LOCK ASSEMBLY-TRUNK LID” part number is **57530FJ020**.

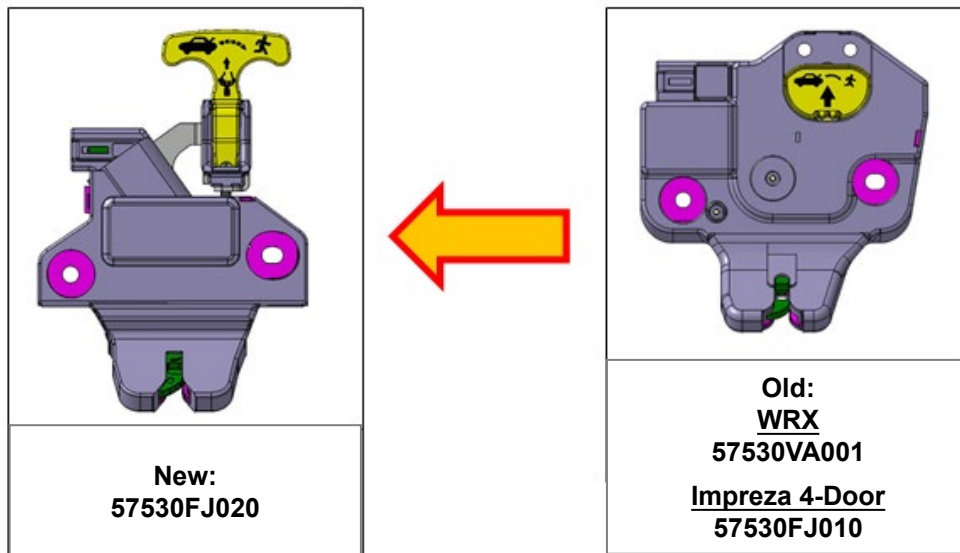

Continued...

CAUTION: VEHICLE SERVICING PERFORMED BY UNTRAINED PERSONS COULD RESULT IN SERIOUS INJURY TO THOSE PERSONS OR TO OTHERS.

Subaru Service Bulletins are intended for use by professional technicians ONLY. They are written to inform those technicians of conditions that may occur in some vehicles, or to provide information that could assist in the proper servicing of the vehicle. Properly trained technicians have the equipment, tools, safety instructions, and know-how to do the job correctly and safely. If a condition is described, DO NOT assume that this Service Bulletin applies to your vehicle, or that your vehicle will have that condition.

Subaru of America, Inc. is ISO 14001 Compliant

ISO 14001 is the international standard for excellence in Environmental Management Systems. Please recycle or dispose of automotive products in a manner that is friendly to our environment and in accordance with all local, state and federal laws and regulations.

SERVICE PROCEDURE / INFORMATION:

The Service procedure for removal and installation of the new trunk lid lock assembly is unchanged. Please refer to the applicable Service Manual.

NOTE: Never use an “Old-style” (p.n. 57530VA001 or 57530FJ010) assembly to replace a T-Handle style lock.

IMPORTANT:

Whenever installing a new T-Handle -type trunk latch assembly, a copy of the updated operating instructions **MUST ALWAYS** be printed out and supplied to the customer to use as an insert for their Owners Manual. All the applicable Owners Manuals have been updated on STIS with this new information which is located near the end of **Section 2**.

WARRANTY / CLAIM INFORMATION:

For vehicles within the Basic New Car Limited Warranty period or covered by an active Subaru Added Security Gold plan, this repair may be submitted using the following claim information:

Labor Description	Labor Operation #	Labor Time	Fail Code
TRUNK LATCH ASSEMBLY R&R	A915-330	0.4	SCL-48

IMPORTANT REMINDERS:

- SOA strongly discourages the printing and/or local storage of service information as previously released information and electronic publications may be updated at any time.
- Always check for any open recalls or campaigns anytime a vehicle is in for servicing.
- Always refer to STIS for the latest service information before performing any repairs.