

- ATTENTION:**
- GENERAL MANAGER
 - PARTS MANAGER
 - CLAIMS PERSONNEL
 - SERVICE MANAGER

IMPORTANT - All Service Personnel Should Read and Initial in the boxes provided, right.

© 2018 Subaru of America, Inc. All rights reserved.



QUALITY DRIVEN® SERVICE

SERVICE INFORMATION BULLETIN

APPLICABILITY: All BRZ Models with 6MT
SUBJECT: Pilot Bearing Change

NUMBER: 03-80-18
DATE: 05/10/18

INTRODUCTION:

This Service Information bulletin announces a change to the flywheel (pilot) bearing to a “environmentally friendly” type which is compliant with the REACH (Registration, Evaluation, Authorization and restriction of CHEMicals) guidelines being used in the European Union (EU). This change is not intended to address any specific customer concern.

PRODUCTION CHANGE INFORMATION:

A starting VIN for the flywheel / bearing will be provided when it becomes available.

PART INFORMATION:

Description	Part Number
FLYWHEEL ASSEMBLY (includes “Green” bearing)	12310AA403
BALL BEARING	806212060

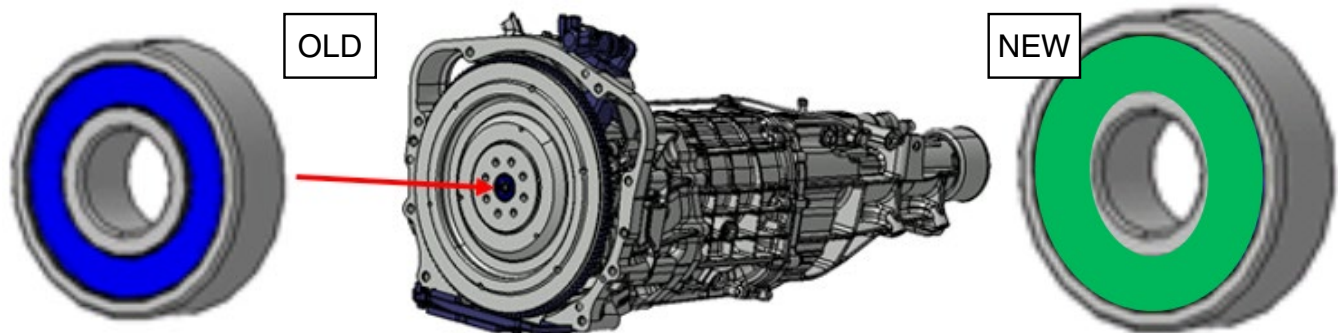

The seal portion of the bearing was changed from blue (old) to GREEN (new) for easy identification.

Continued...

CAUTION: VEHICLE SERVICING PERFORMED BY UNTRAINED PERSONS COULD RESULT IN SERIOUS INJURY TO THOSE PERSONS OR TO OTHERS.

Subaru Service Bulletins are intended for use by professional technicians ONLY. They are written to inform those technicians of conditions that may occur in some vehicles, or to provide information that could assist in the proper servicing of the vehicle. Properly trained technicians have the equipment, tools, safety instructions, and know-how to do the job correctly and safely. If a condition is described, DO NOT assume that this Service Bulletin applies to your vehicle, or that your vehicle will have that condition.

Subaru of America, Inc. is ISO 14001 Compliant

ISO 14001 is the international standard for excellence in Environmental Management Systems. Please recycle or dispose of automotive products in a manner that is friendly to our environment and in accordance with all local, state and federal laws and regulations.

SERVICE PROCEDURE / INFORMATION:

Service procedures for replacement are unchanged. Please refer to the applicable Service Manual.

NOTE: A Blue bearing can be replaced with either Blue or Green but a Green bearing should only be replaced with Green.

IMPORTANT REMINDERS:

- SOA strongly discourages the printing and/or local storage of service information as previously released information and electronic publications may be updated at any time.
- Always check for any open recalls or campaigns anytime a vehicle is in for servicing.
- Always refer to STIS for the latest service information before performing any repairs.