

Classification:

ST08-002f

Reference:

ITB08-046f

COPYRIGHT© NISSAN NORTH AMERICA, INC.

Date:

May 14, 2018

DIAGNOSIS OF VEHICLE PULL (DRIFT) AND/OR STEERING WHEEL OFF CENTER

This bulletin has been amended. Changes have been made throughout. You must read the entire bulletin to properly perform a diagnosis. Please discard previous versions of this bulletin.

APPLIED VEHICLES: All Infiniti

SERVICE INFORMATION

If a customer reports their "vehicle pulls" or the "steering wheel is off-center," use the Diagnostic Flow Chart on page 4 and the other information in this bulletin to diagnose and correct the issue.

Infiniti Bulletins are intended for use by qualified technicians, not 'do-it-yourselfers'. Qualified technicians are properly trained individuals who have the equipment, tools, safety instruction, and know-how to do a job properly and safely. NOTE: If you believe that a described condition may apply to a particular vehicle, DO NOT assume that it does. See your Infiniti retailer to determine if this applies to your vehicle.

General Information

Customers may report that their vehicle's steering wheel is "off-center" because the steering wheel spokes are tilted to the left or right when the vehicle continues straight ahead on a straight flat road (see example in Figure 1).

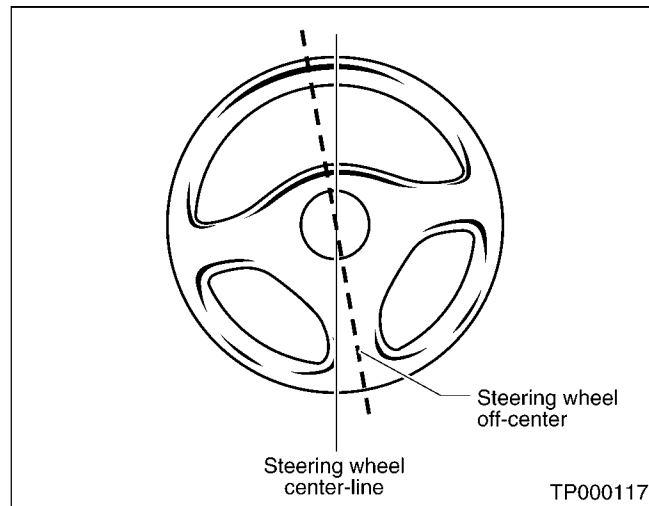

Figure 1

If a vehicle's steering wheel spokes are slightly off center while driving straight, it may be the normal result of road crown. Most roads in the United States are built with a "crown" to help rain water drain from the road surface. The slope of the road crown varies from place to place.

Vehicles have a natural tendency to drift to the low side of the crown. The greater the slope of the crown, the faster the vehicle will drift in that direction.

Tires and vehicles are designed to counteract the effect of typical road crown, but may not fully counteract the effect of a highly crowned road.

Some freeways slope to both the left and right from the center. When driving on a freeway that slopes in both directions, a vehicle may exhibit a small amount of drift to the left when driving in the left lane and a small amount of drift to the right when driving in the right lane.

This bulletin does not address road crown issues because they are not vehicle related, although the customer may incorrectly perceive them to be.

APPLICABLE WARRANTY

- Vehicle alignment is currently covered by the adjustment Warranty for 12 months/12,000 miles, whichever occurs first, from the vehicle's in-service date.
- Warranty application is limited to correction of a problem based upon a customer's specific complaint.
- If an alignment adjustment to correct a vehicle pull or off-center condition is performed, alignment data needs to be printed out and stored at the dealer.

NOTE: Infiniti may request this stored alignment data to support Warranty Claim.

Road Test

Determine if the vehicle has a pull or steering wheel off-center issue that requires repair.

IMPORTANT:

- If the vehicle has any tire issues, such as:
 - Tires that are different sizes (except when specified from the factory).
 - Significant difference in the amount of wear between any of the tires.
 - Any other tire irregularity or damage to any tire and/or wheel.
- Replace the tire(s) or use known good tires from another vehicle for all road tests and diagnostics in this bulletin.
- Make sure the tire pressure in all of the vehicle's tires are set to the correct pressure specification when cold.

1. Install the following measuring tools on the vehicle:

- Steering Wheel Offset Gauge
- Road Crown Gauge

NOTE: See pages 13 and 14 for a description of these tools and an explanation of their use.

2. Obtain a watch with a second hand (preferably a stopwatch) to use during the road test.

3. Take the vehicle for a road test and confirm the customer's concern.

- Select a flat road where the vehicle can be driven in a straight line at a preferred speed of 60 mph.
- During the road test make sure the vehicle is pointing straight. Don't worry about steering wheel position during the road test.

NOTE:

- If you adjusted the tire pressure or changed the tires before the road test, the issue may have been resolved.
- If there are cross winds strong enough to affect the vehicle's straight line movement, then diagnosis cannot be performed.

4. Determine the vehicle's issue – refer to the definitions of "Pull" on page 5 and Steering Wheel "Off-center" on page 8.

5. When the road test is completed, remove the Road Crown Gauge, leave the Steering Wheel Off-Set Gauge in place until the Service Procedure is complete.

6. Refer to the Flow Chart on page 4 for the next step.

Diagnostic Flow Chart

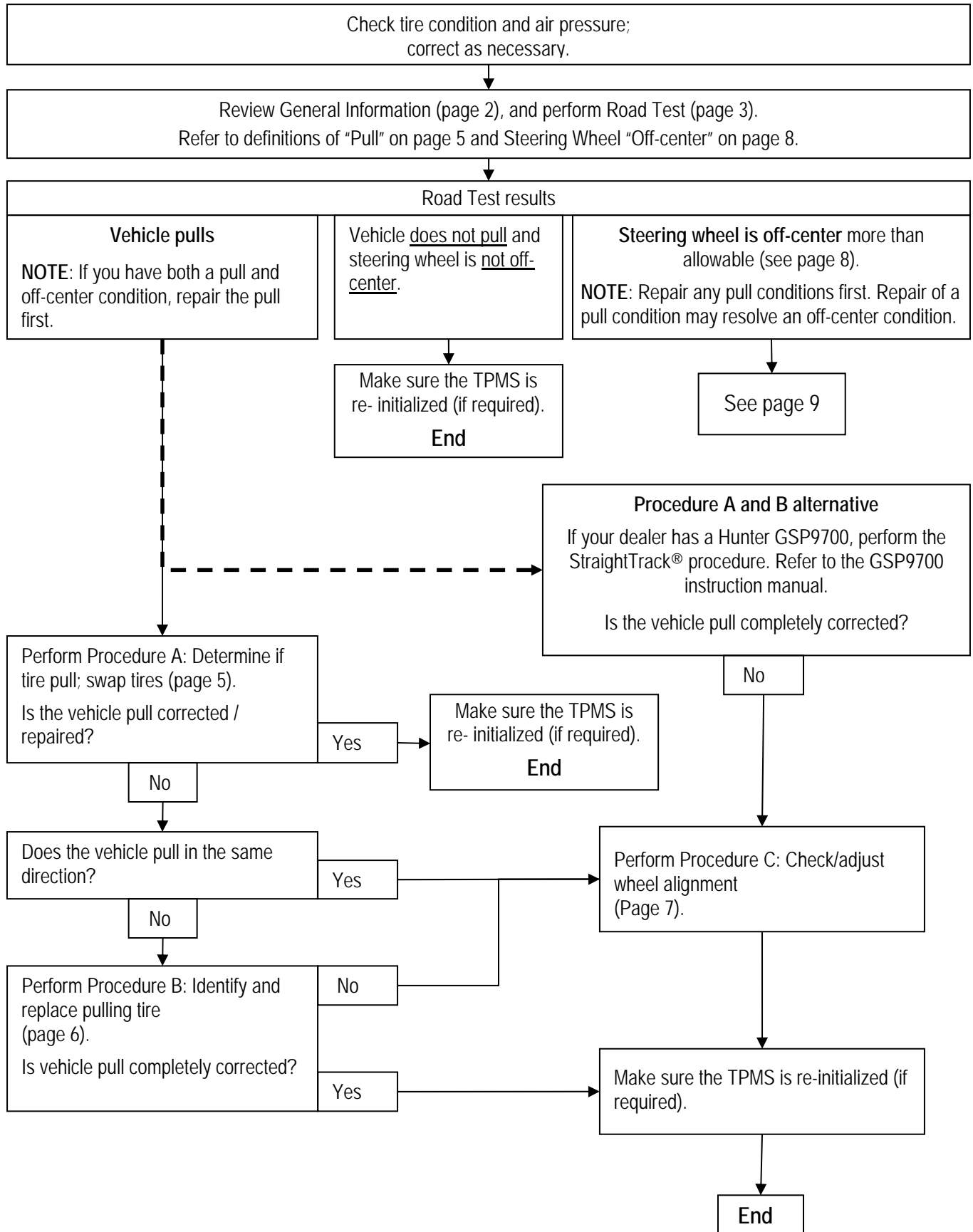

Vehicle Pull or Drift

Description/Definition of a Vehicle "Pull" Condition

The vehicle consistently drifts to one side while driving at a constant speed on a straight, flat road.

- A vehicle is said to "pull" if it completes a lane change in less than 7 seconds (with no steering correction from the driver) when driving at 60 MPH on a road with less than 1.5 degrees road crown slope. All four wheels must pass into the other lane during this time (7 seconds).

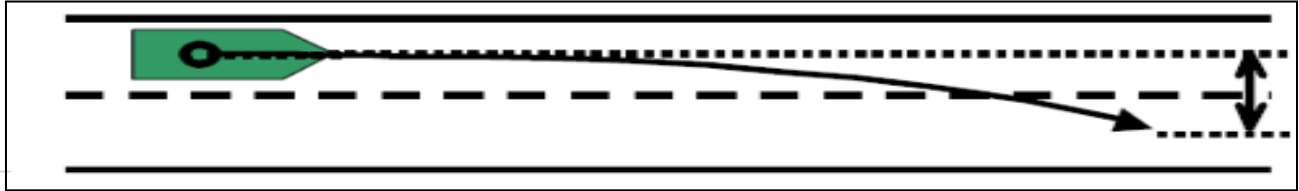

PROCEDURE A (Determine if a pull condition is caused by a tire)

- Always torque wheel lug nuts using a torque wrench to the specified torque. Refer to the appropriate Service Manual for torque specifications.
 - Make sure the tire pressure is set to the correct specification.
 - If the TPMS warning light comes ON, ignore it for now.
1. Swap the front tires side to side (Left to Right and Right to Left).
 2. Swap the rear tires side to side (Left to Right and Right to Left).
 3. Road test the vehicle.
 4. Refer back to the Repair Flow Chart on page 4 for the next step.

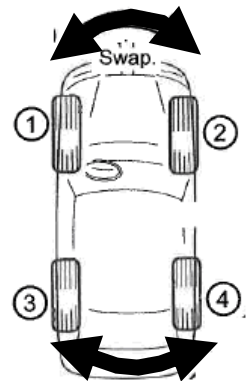

Figure 2

For vehicles with "directional" tires (tires designed to rotate in only one direction):

- a. Swap all four tires from a known good vehicle (known good tires).
- b. Make sure to mark the tires to indicate their original side of the vehicle (left or right).
- c. Road test the vehicle.
- d. If the pull goes away or is reduced, perform Procedure B on the next page to determine which tire was causing the pull.
- e. If the pull is the same, go to Procedure C on page 7.

PROCEDURE B (Determine which tire is causing the pull)

- Procedure B is done only if there is a tire pull issue.
- The steps in Procedure B should identify which tire is causing the pull.
- Make sure the tire pressure in all of the vehicle's tires are set to the correct pressure specification when cold.
- Always torque wheel lug nuts using a torque wrench to the specified torque (refer to the appropriate Service Manual for torque specifications).
- If the TPMS warning light comes ON, ignore it for now.

1a. For vehicles equipped from the factory with tires that are different sizes between the front and rear, or vehicles with "directional" tires:

- A. Put all of the tires/wheels back to original positions. The vehicle should now pull the same as it did on your first road test.
- B. Install / swap only one tire with known good, and road test.
- C. Repeat step B for each tire until the pull goes away or is reduced.
- D. Replace the tire that reduced or eliminated the pull.

NOTE: Make sure directional tires are reinstalled on the same side of the vehicle from which they were removed.

1b. For all other vehicles:

- A. Rotate tires 2 and 4 on the passenger side (see Figure 3) and road test.
 - Pull goes away or is reduced; replace tire 2 (which is now on the rear).
 - Pull gets worse; replace tire 4 (which is now on the front).
 - No change; put tires 2 and 4 back to their original positions.
- B. Rotate tires 1 and 3 on the driver side (see Figure 2) and road test.
 - Pull goes away or is reduced; replace tire 1 (which is now on the rear).
 - Pull gets worse; replace tire 3 (which is now on the front).
 - No change; put tires 1 and 3 back to their original positions.

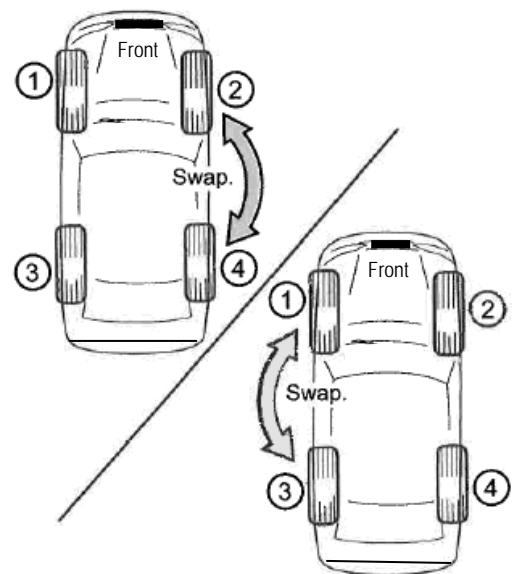

Figure 3

NOTE: When replacing a tire, if there is significant tread wear it is good practice to replace tires in sets (both front, both rear, or all 4).

2. Procedure B should have been done only if there is a **tire pull** issue:
 - If an incident tire was identified and replaced, go to step 3.
 - If an incident tire was not identified, diagnostics were not done correctly. Go back to the Flow Chart on page 4 and start over.
3. After replacing a tire, road test the vehicle.
 - You may have completely corrected the pull or you may have only reduced the pull.
4. Return to the Repair Flow Chart on page 4 for the next step.

PROCEDURE C (Check adjust wheel alignment)

1. Check the vehicles four-wheel alignment using accurate and properly calibrated computerized alignment equipment.
 - A copy of the yearly alignment machine calibration certification must be held on file in the Service Dept.
 - Reference the appropriate Service Manual for alignment specification.
2. If any of the alignment measurements are out of specification, inspect the suspension and chassis for any damage. Repair the damaged components before continuing.
3. Adjust any front and/or rear adjustable alignment components that are out of specification.
 - Always perform rear adjustment first.
 - Reference the appropriate Service Manual for information regarding the proper steps to adjust the alignment.
 - Make sure the steering wheel is straight when adjusting the front wheel toe.

HINT: The Steering Wheel Offset Gauge (or masking tape) can be used to center the steering wheel while standing outside of the car during the alignment process.
4. If necessary, use CONSULT-III plus (C-III plus) to adjust the Steering Angle Sensor.
 - Refer to the appropriated Electronic Service Manual (ESM) to determine if this adjustment is necessary.

Steering Wheel off Center

Description/Definition of Steering Wheel "Off-center" Condition

The steering wheel spokes are tilted to the left or right more than allowable (see example in Figure 4) when driving straight ahead on a straight flat road at 30 MPH.

Allowable specification for steering wheel off-center

- All Infiniti: 2 mm or less.

When driving straight on a highly crowned road, the steering wheel may be turned (off-center) to counteract the effect of the road crown. When road testing for an off-center condition, the vehicle should be driven on a straight flat road at 30 MPH.

Although the vehicle does not pull in either direction, the customer may perceive that the vehicle pulls because it will respond if he or she tries to bring the steering wheel back to center.

- This condition can occur if the tie rod length is uneven (not adjusted correctly) from side to side.

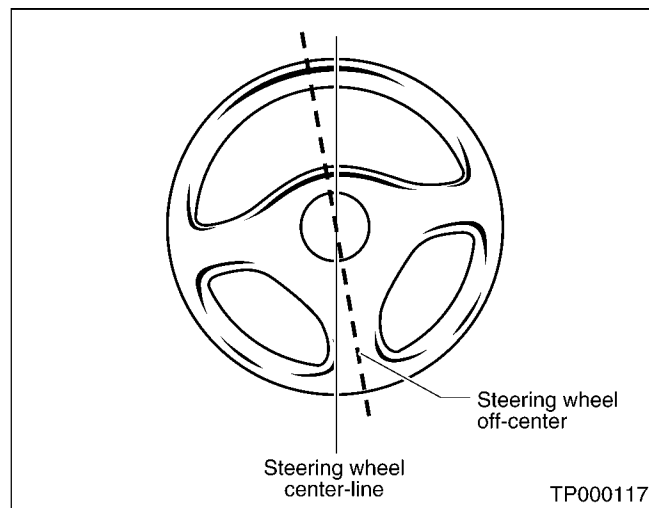

Figure 4

NOTE: Install the following measuring tools onto the vehicle.

- Steering Wheel Offset Gauge.
- Road Crown Gauge.
 - See pages 13 and 14 for a description of these tools and an explanation of their use.

Adjust/correct steering wheel off-center

1. Check the vehicles front toe alignment using accurate and properly calibrated computerized alignment equipment.
 - A copy of the yearly alignment machine calibration certification must be held on file in the Service Dept.
 - Reference the appropriate ESM for alignment specification.
2. If alignment measurements are out of specification, inspect the suspension and chassis for any damage. Repair the damaged components before continuing.
3. Adjust alignment to correct the off-center condition.
 - Reference the appropriate ESM for information regarding the proper steps to adjust the alignment.
 - Make sure the steering wheel is straight when adjusting the front wheel toe.

HINT: The Steering Wheel Offset Gauge (or masking tape) can be used to center the steering wheel while standing outside of the car during the alignment process.
4. Road test to confirm the steering wheel is straight (not off-center 2 mm or more).
5. Remove the steering wheel off-set gauge.
6. Attach to the Repair Order a copy of the alignment machine printout showing the BEFORE and AFTER alignment readings. Write on the print-out the amount of steering wheel off-center (in millimeters) before and after the alignment.
7. If necessary, use C-III plus to adjust the Steering Angle Sensor.
 - Refer to the appropriate ESM to determine if this adjustment is necessary.

NOTE:

- If wheel alignment is performed, attach a copy of the alignment machine print-out showing the Before and After alignment readings.

CLAIMS INFORMATION

Submit a Primary Operation (PO) line claim using the following claims coding:

IF REQUIRED:

DESCRIPTION	OP CODE	SYM	DIA	FRT
Procedure A: Swap front and rear tires (side to side) and re-initialize TPMS	PX35AA	CA	44	0.5 hrs.

IF REQUIRED:

DESCRIPTION	OP CODE	SYM	DIA	FRT
Procedure B: Swap tires per procedure B, perform up to two test drives, and re-initialize TPMS.	PX36AA	CA	02	0.9 hrs.

OR

For vehicles with different size tires or directional tires.

DESCRIPTION	OP CODE	SYM	DIA	FRT
Procedure B: Swap tires per procedure B, perform test drive and re-initialize TPMS.				
If 1 tire is swapped use	PX37AA	CA	02	0.4 hrs.
If 2 tires are swapped use	PX38AA	CA	02	0.8 hrs.
If 3 tires are swapped use	PX39AA	CA	02	1.1 hrs.
If 4 tires are swapped use	PX40AA	CA	02	1.5 hrs.

IF REQUIRED:

DESCRIPTION	OP CODE	SYM	DIA	FRT
Alternative Procedure A and B Wheel Balance	WD52AA	CA	44	(1)

(1) Reference the current Infiniti Warranty Flat Rate Manual and use the indicated FRT.

OR:

DESCRIPTION	OP CODE	SYM	DIA	FRT
Procedure C: Adjust wheel alignment	(2)	CA	44	(3)

(2) Reference the WD-Chassis Adjustment section in the current Infiniti Warranty Flat Rate Manual, use the OP-CODE that matches the vehicle and operation performed.

(3) Reference the current Infiniti Warranty Flat Rate Manual and use the indicated FRT.

IF REQUIRED:

For tire replacement claims information, reference the current Infiniti Warranty Flat Rate Manual.

Submit a Primary Operation (PO) line claim using the following claims coding:

DESCRIPTION	OP CODE	SYM	DIA	FRT
Steering Wheel Off-Center – Adjust	WD34AA	EC	44	(1)

(1) Reference the current Infiniti Warranty Flat Rate Manual and use the indicated FRT.

NOTE: If wheel alignment is performed, attach a copy of the alignment machine print-out showing the Before and After alignment readings.

Appendix

Relationship of alignment settings to vehicle pull:

Camber:

The camber thrust direction will be to the side with the "most positive" camber setting.

EXAMPLE: If the left camber is significantly higher (more positive) than the right, the vehicle will tend to drift or pull to the left.

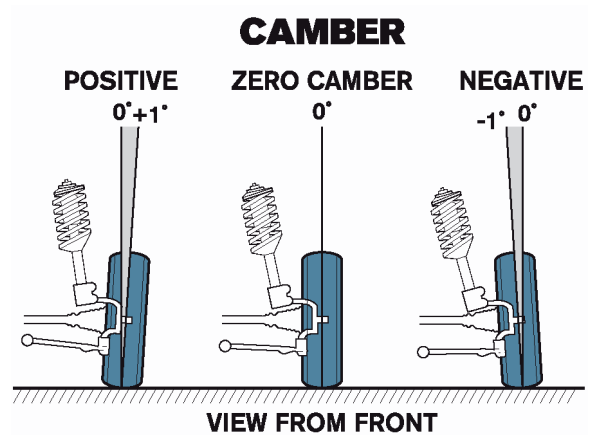

Figure 5

Caster:

The caster thrust direction will be to the side with "most negative" caster setting.

EXAMPLE: If the left caster is significantly higher (more positive) than the right, the vehicle will tend to drift or pull to the right.

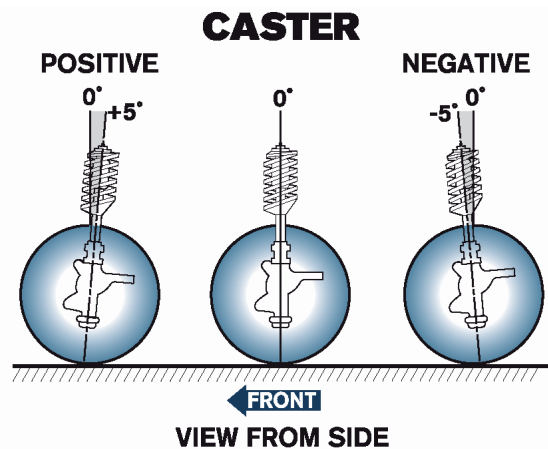

Figure 6

Thrust Angle:

The rear Thrust Angle should be close to 0. Excessive thrust angle may cause the steering wheel to be off-center.

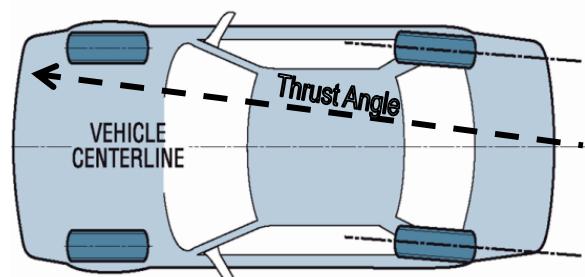

Figure 7

Appendix: (continued)

Caster Camber adjustment

There are no provision provided for adjusting caster and camber on many Nissan/Infiniti models, but some adjustment may be achieved by the following methods:

Strut Suspension Camber Adjustment

- a. Raise the vehicle and remove the front tires.
- b. Loosen the upper steering knuckle bolts and nuts.
- c. Adjust the camber by moving the steering knuckle within the range of the free play of the bolts.
- d. Tighten the bolts to the specified torque (refer to the Service Manual).
- e. Reinstall the front wheels and lower the vehicle. Jounce (bounce) the front and rear of the vehicle several times to stabilize the suspension.

Strut Suspension Camber & Caster Adjustment

- a. Raise the vehicle and remove the front wheels.
- b. Loosen the upper strut mount bolts.
- c. Adjust camber and caster by moving the upper strut mount within the range of the free play of the bolts.
- d. Tighten the bolts to the specified torque (refer to the Service Manual).
- e. Reinstall the front wheels and lower the vehicle. Jounce (bounce) the front and rear of the vehicle several times to stabilize the suspension.

Cradle Camber & Caster Adjustment

- a. Loosen all of the cradle bolts. (DO NOT remove any of these bolts.)
- b. Adjust camber and caster by moving the cradle within the range of the free play of the bolts. (Side to side movement will change Camber and SAI; Fore-Aft movement will change Caster).
- c. Tighten the bolts to the specified torque (refer to the Service Manual).
- d. Jounce (bounce) the front and rear of the vehicle several times to stabilize the suspension.

SPECIAL TOOLS

Steering Wheel Offset Gauge (Stickers) – Tool # J-49286-3

The Steering Wheel Offset Gauge is a set of one-time use stickers that are attached to the steering wheel and the steering column cover.

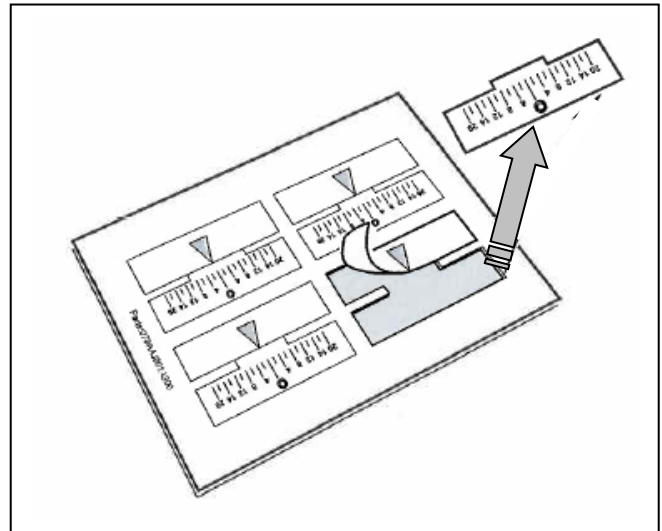

Figure 8

Tool Use

Turn / adjust the steering wheel to the straight position (spokes of steering wheel are straight across).

Attach the sticker with numbers on the steering column cover.

Attach the arrow sticker on the steering wheel. Make sure the arrow lines up with the 0 (zero) mark.

When you road test the vehicle you can read how many millimeters the steering wheel is off-center.

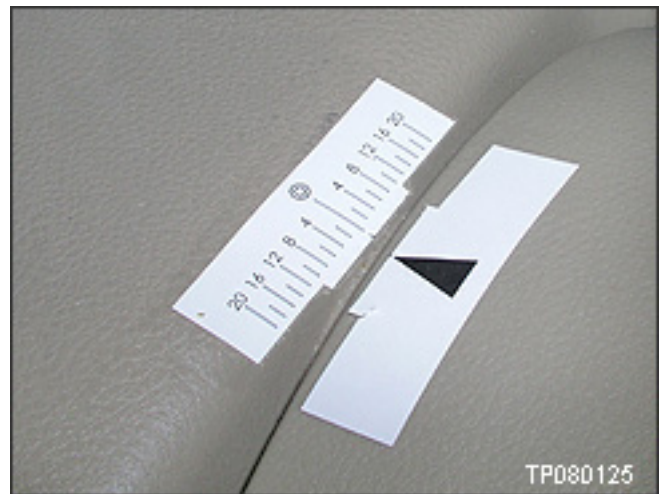

Figure 9

NOTE: If stickers are not available, use a piece of masking tape on the steering wheel and on the steering column. Mark where the steering wheel is centered and a maximum mark to either side (refer to page 8 for vehicle maximum allowable offset).

- Additional tools can be ordered from TECH-MATE at 1-800-662-2001.

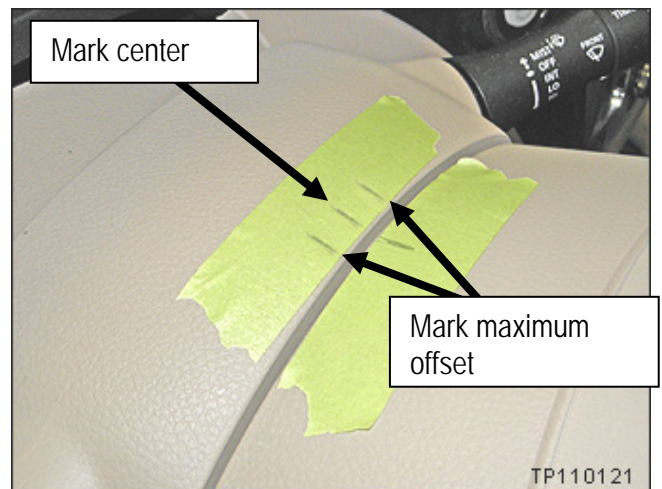

Figure 10

Road Crown Gauge – Tool # J-49286-2

The Road Crown Gauge measures the amount of road crown in degrees.

The suction cup is used to attach the Road Crown Gauge to a secure spot on the vehicle dash.

Tool Use

Before the road test, calibrate the gauge:

NOTE: The gauge must be calibrated with the same weight in the vehicle as there will be during the road test. For example, if you plan to have an assistant in the vehicle during the road test, calibrate the gauge while both of you are sitting in the vehicle.

There are two ways to calibrate the gauge:

- Preferred method: Park the vehicle on a level surface, such as an alignment rack and calibrate the gauge by moving the gauge until the ball is on the zero mark.
- If you do not have a perfectly flat level surface:
 - a. Park the vehicle on a reasonable flat level surface and note the gauge reading.
 - b. Turn the vehicle 180 degrees so the vehicle is in the same spot but facing the opposite direction and note the gauge reading.
 - c. Move / calibrate the gauge so it reads half the difference between the two readings.

For example; if the first reading is -1 and the second reading (after moving the vehicle) is +3, half way between is +1.

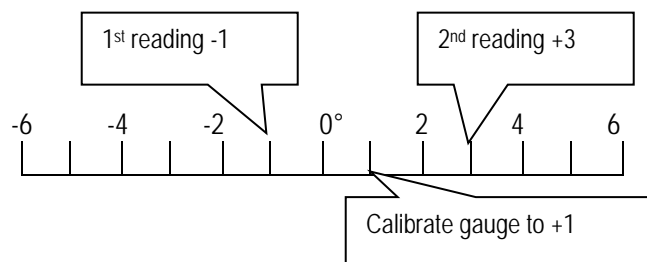

Figure 11



Figure 12