



INSTRUCTION TO SERVICE

ITS: 6830	
SECTION:	580 Wheelchair Ramp
WRITTEN BY:	Dwayne Peters
SUBJECT:	Add a Wheelchair Ramp Pull Handle

ITS6830

THIS DOCUMENT AND THE CONTENTS DISCUSSED HEREIN ARE THE CONFIDENTIAL AND PROPRIETARY INFORMATION OF NEW FLYER INDUSTRIES CANADA ULC AND NEW FLYER OF AMERICA INC. AND ARE DISCLOSED BY NEW FLYER IN CONFIDENCE. THIS DOCUMENT AND THE CONTENTS HEREIN ARE NOT TO BE DISCLOSED BY THE INTENDED RECIPIENT WITHOUT THE PRIOR WRITTEN AUTHORIZATION OF NEW FLYER. ANY UNAUTHOIZED DISCLOSURE, REPRODUCTION OR OTHER DISTRIBUTION OF THIS DOCUMENT OR INFORMATION IS STRICTLY PROHIBITED AND MAY RESULT IN ACTION BEING TAKEN AGAINST THE PARTY MAKING THE UNAUTHORIZED DISCLOSURE. THIS DOCUMENT AND ALL COPIES HEREOF MUST BE RETURNED TO NEW FLYER UPON REQUEST.



NEW FLYER

PROCEDURE:

1. Turn the main battery disconnect switch to the "OFF" position.
2. Apply NF 101156 to tool as shown in figure 1.
3. Apply NF 101157 to NF 101156 and trim to fit.

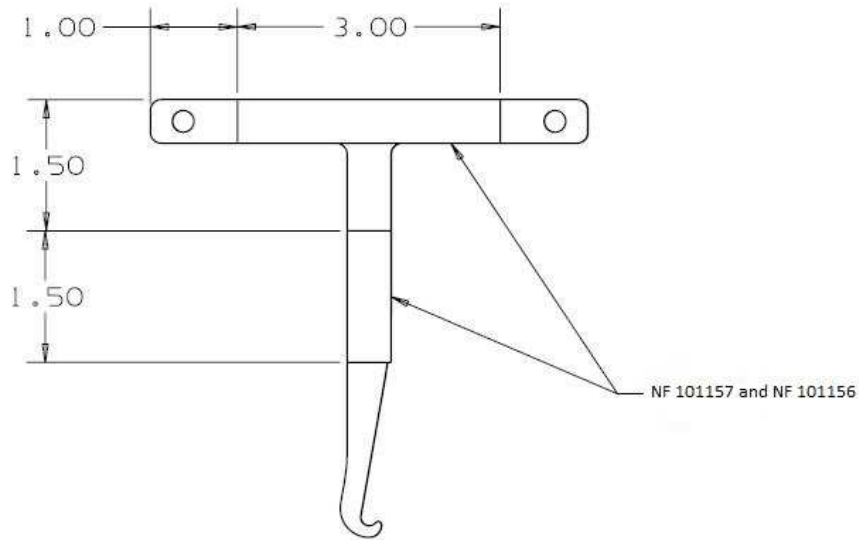

Figure 1: Velcro Location

4. Install NF 561760 tool containing NF 101156 and NF 101157 in the driver's storage box as shown in figure 2.

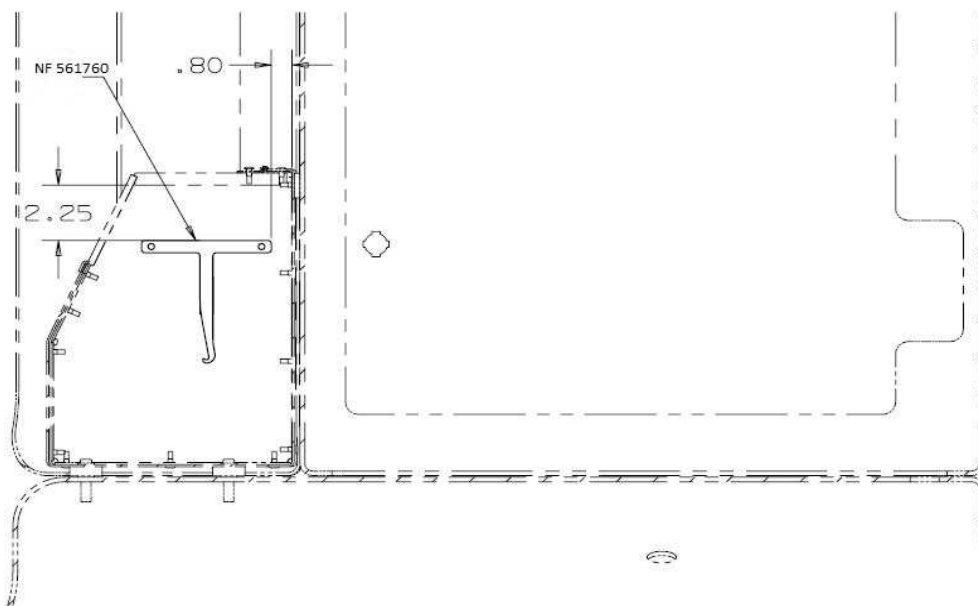

Figure 2: Tool location

5. Turn the main battery disconnect switch to the "ON" position.



NEW FLYER

LABOUR ESTIMATE

	Operation	Men	Hours	Labour Time M X HR
1	Install Wheelchair ramp pull handle	1	0.5	0.5

PARTS REQUIRED

Item	Part Number	Description	Qty. per Coach	Units	Notes
1	561760	LATCH-HANDLE W/C RAMP	1	EA	
2	101157	TAPE-VELCRO 1.0 WIDE HOOK	0.375	FT	
3	101156	TAPE-VELCRO 1.0 WIDE LOOP	0.375	FT	