



INSTRUCTION TO SERVICE

ITS: 6790	
SECTION:	304 Paint and Decals
WRITTEN BY:	Troy Stutsky
SUBJECT:	Add two CNG diamond decals

ITS6790

THIS ITS DOCUMENT SHOULD BE RETAINED AND REFERED TO FOR FUTURE MAINTENANCE UNTIL THE NEW FLYER PARTS AND/OR SERVICE MANUAL IS UPDATED TO REFLECT WORK DONE AS A RESULT OF THIS DOCUMENT. ENSURE THAT THIS DOCUMENT IS AVAILABLE FOR PARTS AND MAINTENANCE STAFF GOING FORWARD.

THIS DOCUMENT AND THE CONTENTS DISCUSSED HEREIN ARE THE CONFIDENTIAL AND PROPRIETARY INFORMATION OF NEW FLYER INDUSTRIES CANADA ULC AND NEW FLYER OF AMERICA INC. AND ARE DISCLOSED BY NEW FLYER IN CONFIDENCE. THIS DOCUMENT AND THE CONTENTS HEREIN ARE NOT TO BE DISCLOSED BY THE INTENDED RECIPIENT WITHOUT THE PRIOR WRITTEN AUTHORIZATION OF NEW FLYER. ANY UNAUTHOIZED DISCLOSURE, REPRODUCTION OR OTHER DISTRIBUTION OF THIS DOCUMENT OR INFORMATION IS STRICTLY PROHIBITED AND MAY RESULT IN ACTION BEING TAKEN AGAINST THE PARTY MAKING THE UNAUTHORIZED DISCLOSURE. THIS DOCUMENT AND ALL COPIES HEREOF MUST BE RETURNED TO NEW FLYER UPON REQUEST.

PROCEDURE:

1. Turn the main battery disconnect switch to the “OFF” position.
2. Clean the locations on the CS and SS side screen panel where the new decals (NF PN 065959) will be installed. Use a lint free cloth moistened with isopropyl alcohol (NF PN 134336) and wipe the area clean. Allow 5 mins to flash off. See Figure 1 for locations.
3. Install the new decals in the locations shown in Figure 1.

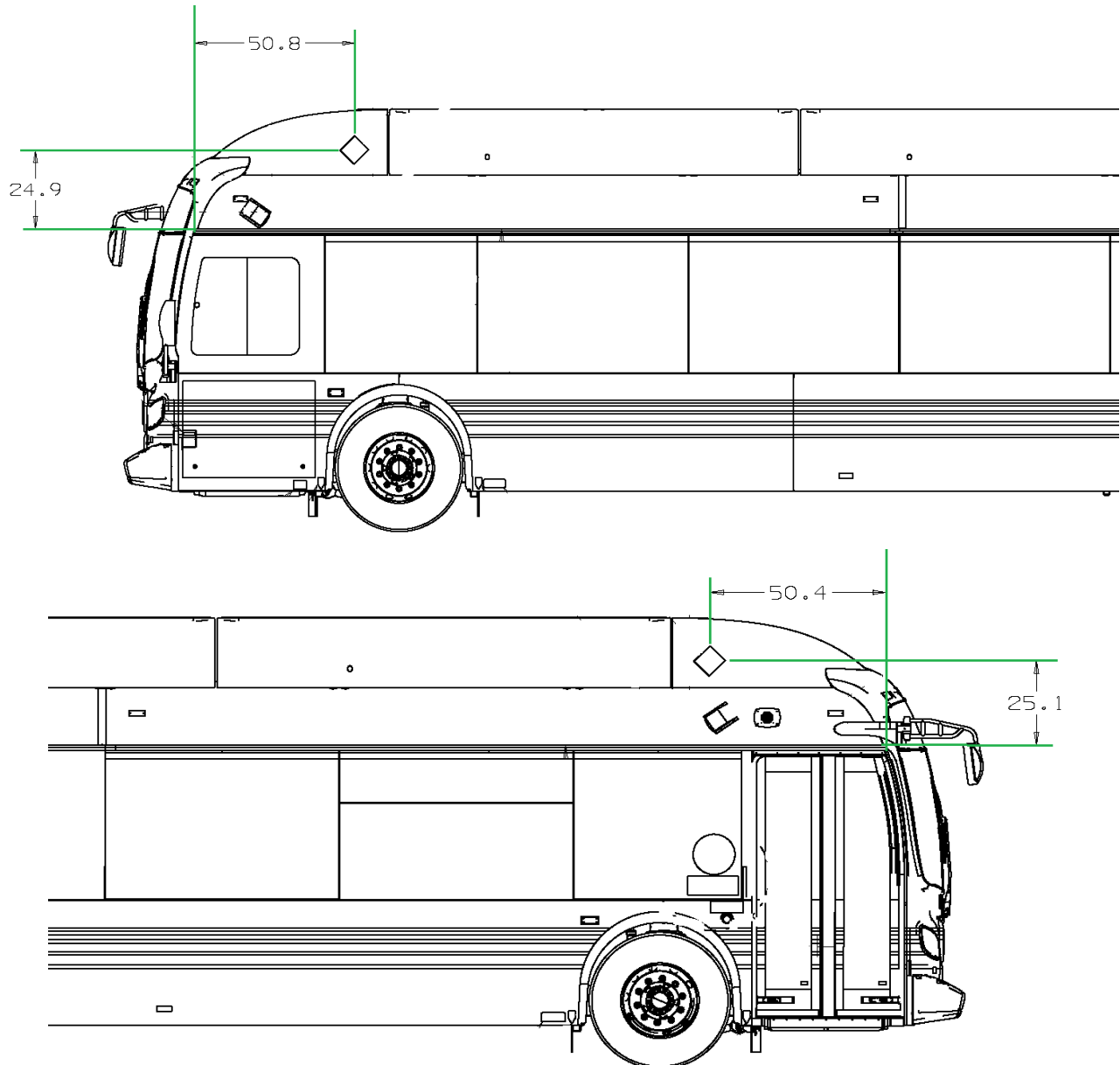

Figure 1: New CNG decal locations

4. Remove all tools and debris and return the bus to service condition.
5. Turn the main battery disconnect switch to the “ON” position.



NEW FLYER

LABOUR ESTIMATE

	Operation	Men	Hours	Labour Time M X HR
1	Install two new CNG diamond decals	1	0.25	0.25

PARTS REQUIRED

Item	Part Number	Description	Qty. per Coach	Units	Notes
1	065959	DECAL-CNG(REFL) PREMASK	2	EA	
2	134336	ISOPROPYL-ALCOHOL	0.01	EA	Source Locally