

**ISSUE:** LANDING GEAR MOUNT/BRACE WERE BENDING IN SERVICE

**MATERIAL REQUIRED:**

SEE BOM

**REPAIR INSTRUCTIONS:**

1. SUPPORT KING PIN AREA ON A SUITABLE SAWHORSE TO SAFELY ALLOW THE LANDING GEAR TO BE REMOVED
2. UNBOLT AND REMOVE THE EXISTING LANDING GEAR AND BRACES. KEEP THE LEGS FOR REUSE. DISCARD THE BRACE PIPES. KEEP THE BOLTS. (SEE FIGURE 2)
3. USING A DISK GRINDER AND ABRASIVE CUT OFF DISK, REMOVE THE MOUNTING PADS ON THE MAIN BEAM WEBS AND ON THE CROSS CHANNEL BETWEEN THE LEGS.
4. USING THE SAME GRINDER TO REMOVE THE ATTACHMENT EARS FROM THE BOTTOM OF EACH LANDING GEAR LEGS.
5. GRIND SMOOTH ALL AREA THAT HAVE BEEN CUT OFF FROM LANDING GEAR AND TRAILER
6. USE JIG 98AA1315 TO INSTALL NEW LANDING GEAR TABS ON CURBSIDE & 98AA1316 TO INSTALL THE TAB ON ROADSIDE LANDING GEAR
  - I. PLACE JIG AT THE BOTTOM OF THE UPPER PART OF THE LANDING GEAR SO IT WOULD BE FACING THE REAR OF THE TRAILER AND INWARDS (SEE FIGURE 1)
  - II. TEMPORARILY BOLT THE TABS ITEM ③ AND ④ TO THE JIG, ITEM ③ WILL BE FACING THE REAR WHILE ITEM ④ WILL BE FACING INWARDS
  - III. WELD ITEM ③ AND ④ IN PLACE ON THE LANDING GEAR; 1/4" WELD
  - IV. REMOVE JIG AND WELD THE OTHERSIDE OF ITEM ③ AND ④ WITH 1/4" WELDS
  - V. TOUCH UP WELDED AREAS WITH PRIMER AND PAINT THAT HAVE BEEN WELDED
  - VI. REPEAT WITH OTHER SIDE
7. PLACING STIFFENER BAR AT THE LANDING GEAR MOUNT ATTACHED TO THE WEB (SEE FIGURE 2)
  - I. CHECK MOUNT TO SEE IF THERE ARE ANY CRACK IN IN THE WELDS
  - II. IF THERE ARE GRIND THEM OUT AND REWELD THE MOUNT
  - III. ADD ITEM ⑦ TO MOUNT AND WEB INSTALL THE WAY YOU SEE IN FIGURE 2 & SECTION A-A-
  - IV. WELD STIFFENER AS PER FIGURE 2 & SECTION A-A
  - V. TOUCH UP PART WITH PRIMER AND PAINT WHERE THE PART HAS BEEN WELDED
8. REINSTALL THE LANDING GEAR LEGS ONTO THEIR MOUNTS, REUSING THE ORIGINAL BOLTS/NUTS.
9. INSTALLING BRACE AND MOUNT (SEE FIGURE 3)
  - I. BOLT ITEM ② AND HAND TIGHTEN PART TO INSIDE LANDING GEAR ITEM ④ AND ALSO BOLT ITEM ⑦ TO ITEM ⑥ DO THE SAME ON THE OTHER SIDE
  - II. TACK ITEM ⑥ TO THE LANDING GEAR CROSSMEMBER
  - III. REMOVE BRACE SO YOU CAN WELD UP ITEM ⑥ FULLY TO THE LANDING GEAR CROSSMEMBER
  - IV. BOLT ITEM ② WITH ITEM ③ AND ITEM ② WITH ITEM ①
  - V. MATCH DRILL THE 1/2" BOLT HOLE IN ITEM ① TO THE WEB
  - VI. REPEAT STEP IV AND V IN THIS SECTION FOR OTHER SIDE
  - VII. REMOVE BRACES TO TOUCH UP PAINT IN ALL THE WELDED AND DRILL AREAS
  - VIII. INSTALL THE NEW MOUNTS. ITEM ①, USING 1/2" BOLTS IN THE KIT.
  - IX. INSTALL ALL OF THE NEW BRACES TUBES USING NEW BOLTS IN THE KIT.
  - X. TIGHTEN ALL OF THE BOLTS AND VERIFY THEY SECURITY OF THE LANDING GEAR TO THE TRAILER
10. CRANK THE LANDING GEAR UP TO LIFT THE TRAILER FRAME OFF THE SUPPORTING SAW HORSE.
11. VERIFY THAT THE NEW BRACES AND MATING STRUCTURE ARE WORKING CORRECTLY AND SAFELY BEFORE PUTTING THE TRAILER BACK INTO SERVICE

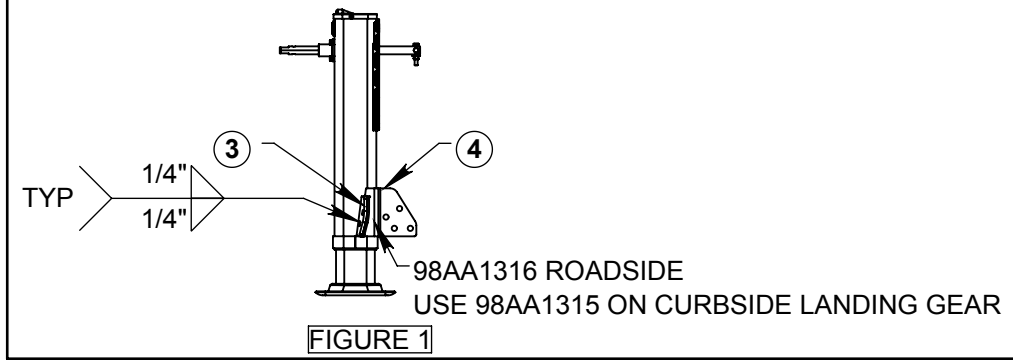
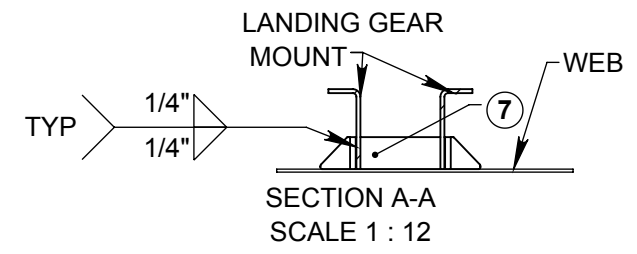
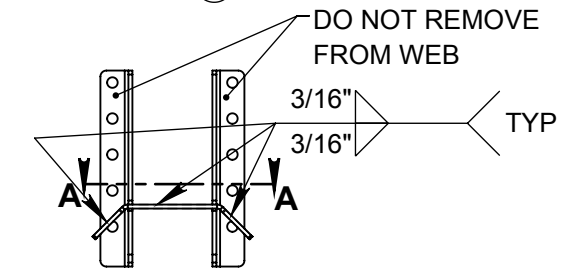
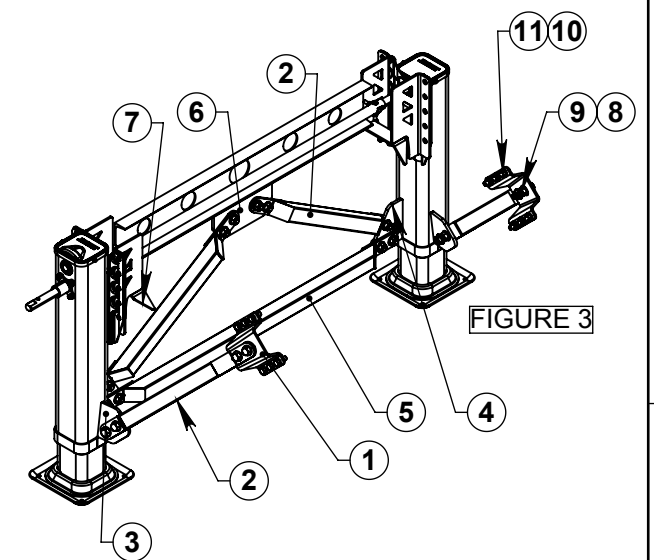

**APPLICATION NOTE:**

1. THIS UPDATE INTENDED FOR TRAILERS WITH VIN ENDING 64829 THRU 64841

Mass = lbs

REV.	ECO NO.	BY	DATE	DESCRIPTION
1	113789	MM	18-Apr-2018	ISSUE

ITEM NO.	QTY.	PART NO.	DESCRIPTION
1	2	35AC0558	MOUNT, LANDING GEAR
2	4	35AB0226	LANDING GEAR BRACE ASY
3	2	35AC0555	TAB, LANDING GEAR
4	2	35AC0556	TAB, LANDING GEAR
5	1	35AB0227	LANDING GEAR BRACE ASY
6	1	35AC0557	TAB, LANDING GEAR
7	2	35AC0559	STIFFENER, LANDING GEAR
8	20	12124129	BOLT 5/8 X 1 1/2 GR 8 UNC MAGNI 565
9	20	12124326	HEX NUT-FLG X 5/8-UNC-GR8-565
10	12	12124094	BOLT 1/2 X 1 1/4 GR8 UNC MAGNI 565
11	12	12124304	NUT 1/2 UNC GR-G TOPLOCK MAGNI 565

MATERIAL NO	MATERIAL DESCR
DRAWN MM 18-Apr-2018	DWG FILE: W:\LK25\Field Service Bulletins\FS201805\FS201805 MODEL FILE: W:\LK25\Models\LG\Tyson.LG.LG-Asy
UNLESS OTHERWISE SPECIFIED DIMENSIONS ARE IN INCHES. TOLERANCES ARE: FRACTIONS DECIMALS ANGLES	
± 1/16 X.XX ± 0.06 ± 1°	
X.XXX ± 0.031	
DRAWING TITLE	
<b>REPLACEMENT OF LANDING GEAR BRACES</b>	
THIS DRAWING CONTAINS PROPRIETARY INFORMATION. ITS CONTENTS MUST NOT BE DISCLOSED IN WHOLE OR IN PART WITHOUT THE PRIOR WRITTEN CONSENT OF LODE KING INDUSTRIES.	SCALE: 1:24
SIZE: B	SHEET: 1 OF 1
DWG. NO. <b>FS201805</b>	REV. <b>A</b>

