

DWG. NO. FS201804	REV. A	SHEET 1 OF 1
-----------------------------	------------------	-------------------------------

ISSUE:

RECENTLY CUSTOMERS HAVE BEEN FINDING BROKEN FLOORING SCREWS ON THEIR PRESTIGE TRAILERS FLAT DECKS AND STEP DECKS EQUIPPED WITH ALUMINUM FLOORING. THE PROBLEM HAS BEEN TRACED BACK TO A QUALITY PROBLEM DURING THE MANUFACTURE OF THE SCREWS. REMEDIAL ACTION IS NEEDED TO REMOVE THE DEFECTIVE FLOORING SCREWS AND REPLACE THEM WITH GOOD QUALITY SCREWS. THIS FIELD SERVICE BULLETIN ADDRESSES THIS ISSUE.

APPLICATION:

ANY FLAT DECK OR STEP DECK (PFL, PFK, SDF, SDG MODELS) WITH A 1 5/16" THICK ALUMINUM FLOORING WHERE BROKEN SCREWS ARE OBSERVED. PRESTIGE TRAILERS' ALL ALUMINUM DECKS (PFR AND SDR MODELS) DO NOT USE THESE FLOORING SCREWS AND ARE NOT AFFECTED.

REMOVAL OF SCREWS FOR REPLACEMENT:

DUE TO THE INFERIOR QUALITY OF THE FASTENERS ALL ALUMINUM DECKING SCREWS MUST BE REMOVED AND REPLACED. FOR SCREWS THAT ARE NOT BROKEN REMOVE THE FLOORING SCREW USING A TORX DRIVER BIT. IF ANY DECKING SCREWS HAVE BROKEN THE THREADED PORTION WILL BE STUCK IN THE TRAILERS CROSSMEMBERS. TO REMOVE THE BROKEN SCREWS EITHER THREAD THE SCREW OUT FROM THE BOTTOM OF THE CROSSMEMBERS USING PLIERS FROM UNDERNEATH THE TRAILER OR DRILL OUT THE CENTER OF THE FLOORING SCREW USING A 1/4" LEFT HANDED DRILL BIT.

SCREWS USED TO FASTEN THE WOODEN NAILING STRIPS DO NOT NEED TO BE REMOVED AND REPLACED.

BROKEN SCREW REPLACEMENT PROCEDURE:

ONCE THE ALUMINUM FLOORING SCREWS ARE REMOVED THEY MUST BE REPLACED WITH SCREWS PROVIDED BY PRESTIGE TRAILERS (P/N 12121605) OR APPROVED BY PRESTIGE TRAILERS. SEE SCREW NOTES BELOW FOR SCREW DETAILS. WHEN REPLACING THE ALUMINUM FLOORING SCREWS APPLY MEDIUM STRENGTH LOCTITE (BLUE) TO THE THREADS BEFORE INSERTING INTO THE EXISTING HOLES. TORQUE THE NEW FLOOR SCREWS TO 16 LB-FT.

IF AFTER EXTRACTING THE OLD FLOORING SCREWS THE THREADS IN THE CROSSMEMBERS ARE NO LONGER SUFFICIENT TO HOLD THE SCREW IN PLACE ADD A WASHER AND LOCKING NUT TO THE BOTTOM OF THE SCREW AND TORQUE TO 16 LB-FT.

SCREW NOTES:

1. PRESTIGE TRAILERS SCREW P/N 12121605 IS A 5/16-18x2" PAN HEADED SINGLE START SELF TAPPING SCREW.
2. NEW ALUMINUM FLOORING SCREWS ARE AVAILABLE FROM PRESTIGE TRAILERS' WARRANTY DEPARTMENT.

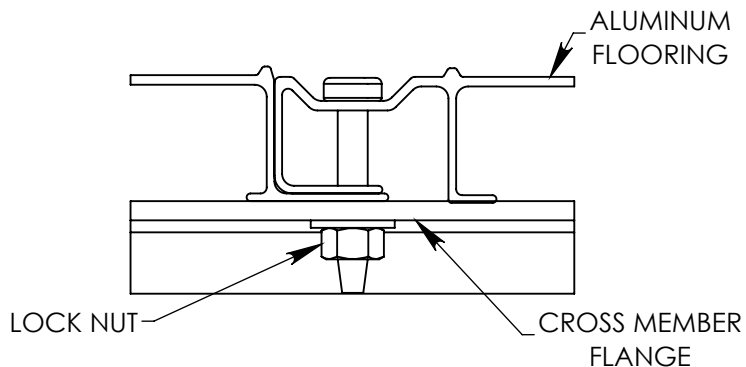

NOTE: LOCK NUT ONLY REQUIRED IF EXISTING THREADS IN CROSSMEMBERS ARE DAMAGED.

LABOR ALLOWANCE: 4 HOURS	
MATERIAL NO	MATERIAL DESCR
DRAWN SV 19-Mar-2018	DWG FILE: A:\LK25\Field Service Bulletins\FS201804\FS201804 MODEL FILE: A:\LK25\Field Service Bulletins\FS201802\al floor detail
UNLESS OTHERWISE SPECIFIED DIMENSIONS ARE IN INCHES. TOLERANCES ARE: FRACTIONS DECIMALS ANGLES ± 1/16 .XXX ± 0.06 ± 1° .XXX ± 0.031	
 BOX 1146 WINKLER MANITOBA CANADA R6W 4B2	
ALUMINUM FLOORING SCREW REPLACEMENT	

	113698	SV	19-Mar-2018	ISSUE	THIS DRAWING CONTAINS PROPRIETARY INFORMATION. ITS CONTENTS MUST NOT BE DISCLOSED IN WHOLE OR IN PART WITHOUT THE PRIOR WRITTEN CONSENT OF TRIPLE E CANADA.	SCALE 2:1	SIZE A	SHEET 1 OF 1	DWG. NO. FS201804	REV. A
	REV.	ECO NO.	BY	DATE						