



Service Bulletin

R1701

Section

42- Coolant

Description

Model Year 2017 Retrofit - Surge Tank

Release Date

4/27/2018

Introduction

Peterbilt has determined that certain pre-production vehicles equipped with PACCAR MX-11 and MX-13 GHG2017 MY2017 engines and built between 11/15/2016 and 12/08/2016 must be updated to production levels. R1701 involves replacing pre-production surge tank parts with a production level surge tank.

Resolution

Campaign

The chassis may require more than one of the campaigns noted below. Ensure that the customer is aware of the complete extent of work that will be performed on their particular chassis.

1. Review the attached chassis list for your dealer code and schedule your customer(s) for service if their chassis is on the list.
2. Confirm with the customer that your dealership will be the repairing location before ordering parts.
3. Prepare an inventory of the parts needed and **ensure all required parts have arrived prior to scheduling the chassis for the retrofit.**
4. Review the DWWC or SIR for "Complete" next to the "R1701" campaign code prior to performing this repair.
5. Follow the procedures below to replace the pre-production surge tank with production parts.

Perform this repair as soon as possible to avoid possibility of civil fines.

NOTE: See DWWC/SIR if one or more of the following campaigns also apply to a given chassis: R1701, R1702, R1703, R1704, R1705, R1706, R1707, R1708, R1709, R1710, R1711, R1712, R1713, R1714, R1715, R1716, R1717, R1718, and R1719.

Warranty

There is no time or mileage limit for this campaign. Peterbilt will pay for parts at dealer net plus applicable mark-up and labor:

- 0.6 hours labor to replace the surge tank. File a long form claim and reference "**R1701**" in the claim.

For Kenworth Trucks:

NOTE: Peterbilt dealers may perform E1701 repairs on Kenworth chassis. For Kenworth chassis repairs, use the long claim input form in DWWC selecting "Draft/Offline Claims," the "General" tab, and in the "Type of Claim" drop down box, select "PACCAR Engine Claim," then manually enter claim codes (Campaign #, Failure type, and SRT).

For Field...	Enter...
Failure Location	042-002-009
Failure Type	700
Claim Type	A
SRT 042-025	0.6 Hours Labor to R&R the surge tank

Parts

Parts are available from PACCAR Parts.

Surge tank parts are listed below:

Quantity	Part Number	Description
1	2141023	DAF Engine Side Adapter
1	DR104004	Surge Tank Assy
1	F50-2050	EPA/HOSE ASSY
1 Gal	EC3501	Coolant for top off

PARTS ORDERING PROCEDURE

Confirm with the customer that your dealership will be the repairing location before ordering parts and obtain the chassis number. **All orders** must be requested **through SupportLink**. Please refer to the following instructions for how to submit a SupportLink case:

1. SupportLink Case—Customer Service|Chassis Specific Orders|Other and in the **Other*** field enter "2017 QV Retrofit".
2. Enter **all** part numbers that are needed based on the Retrofit bulletins associated with the specific chassis number.
 - If a list of part numbers is not provided in the case, the order will not be placed.** It will not be assumed all parts on the bulletins are needed since some could already be in dealer inventory. Only the

- part numbers provided will be ordered.
3. Enter the chassis number in its designated field. **This is required for the order to be placed to validate participation in the retrofit.**
 4. Provide shipping method.
 5. PPD will ship these requested parts for the specific chassis:

Contents: retrofit parts per chassis (as provided in step #2)

Shipping method: as provided in step #4

Delivery time: depends on instruction

Packing slip will include:

- Dealer Order Number as: "RETRO CH [ChassisNumber]"
 - Packing List (this may or may not match the Chassis\Parts List attached to this bulletin depending on availability of parts).
 - Secondary shipments will be identified on the order number with a suffix number, e.g. [ChassisNumber]-2. This applies to parts that are not available at the time of the initial TIB posting.
6. Ensure both the Parts and Service Managers are aware of the chassis specific order.
 7. **Ensure your dealership has all parts on hand before scheduling retrofit work.**

Procedure

R1701 Procedure:

1. Drain the coolant into a clean container. The coolant will be reused.
2. Remove the surge tank.
3. Install the new surge tank.
4. Install the adapter on the surge tank as shown in the following images.

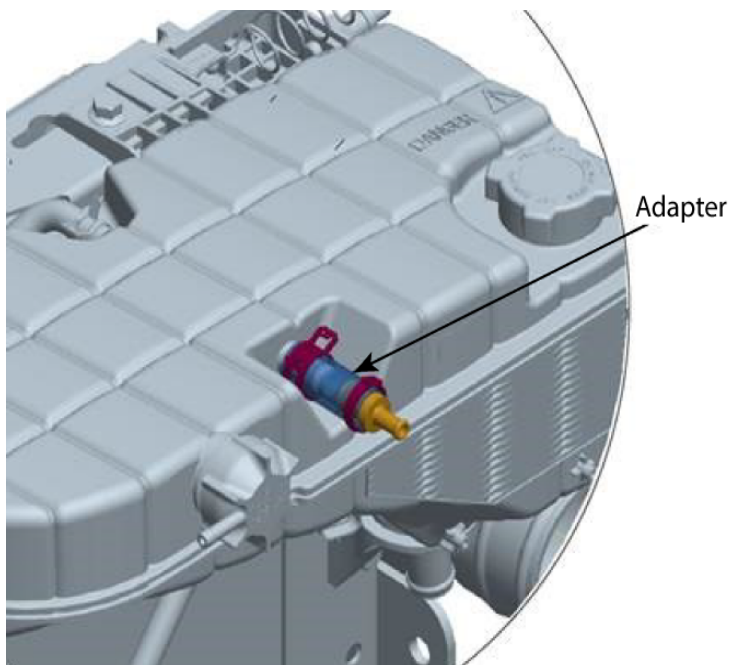

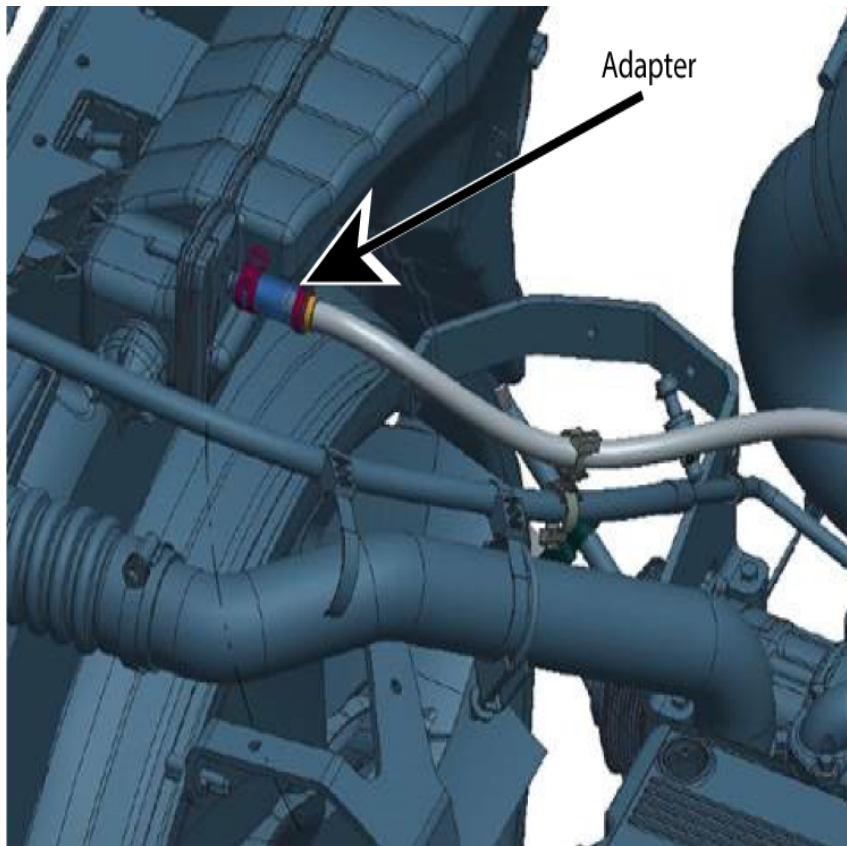

5. Connect the hose from the engine to the adapter on the surge tank.
6. Fill the cooling system with the removed coolant.

Attachments

[R1701 Chassis List](#)

Access to PACCAR's Enterprise Portal is provided as a benefit of doing business with PACCAR. All applications and content accessed through this system are confidential and proprietary and the property of PACCAR Inc and its suppliers, and must be kept strictly confidential pursuant to the contract licensing such access. Disclosure, publication, release or distribution of any material found on PACCAR systems to any person other than employees with a need to know such information is strictly prohibited. All activity on this system is monitored. If PACCAR suspects or discovers any unauthorized activity, access may be immediately terminated without prior notification. Violators may be subject to legal action.

© Copyright 2018 PACCAR Inc. All rights reserved. We welcome your [feedback](#) on this page. For technical questions or concerns about this page, please contact the [DealerNet Webmaster](#).