

Date	Expiration	Release	Page
03.2018	03.2019	4	1(11)

Revision: D	Warranty Material Return Tag added.	03-22-2018
-------------	-------------------------------------	------------

DRAG LINK REPLACEMENT

Prevost vehicles

DESCRIPTION

On the vehicles affected by this bulletin, proceed to the replacement of the drag link.

MODEL YEAR(S) AND VEHICLES INVOLVED

<i>NOTICE TO SERVICE CENTERS</i>	
<i>Verify vehicle eligibility by checking warranty bulletin status with SAP or via ONLINE WARRANTY SYSTEM available on Service / Warranty tab of Prevost website.</i>	
Model	VIN
X3-45 coaches Model Year : 2008 - 2010	From 2PCG334908C72 <u>9426</u> up to 2PCG33499AC72 <u>9866</u> incl.
X3-45 coaches Model Year : 2011 - 2014	From 2PCG33491BC73 <u>5050</u> up to 2PCG33495EC73 <u>5525</u> incl.
H3-45 coaches Model Year : 1999, 2000, 2005	<p><u>Early model year(s):</u> 2PCH33491<u>X</u>101<u>2855</u></p> <p> 2PCH33491<u>X</u>101<u>2861</u></p> <p> 2PCH33490<u>Y</u>101<u>3772</u></p> <p> 2PCH33495<u>Y</u>101<u>3802</u></p> <p> 2PCH33497<u>Y</u>101<u>3820</u></p> <p><u>Late model year(s):</u> 2PCH33493<u>5</u>101<u>0232</u></p>
<p>This bulletin does not necessarily apply to all the above-mentioned vehicles, some vehicles may have been modified before delivery.</p>	

Date	Expiration	Release	Page
03.2018	03.2019	4	2(11)

MATERIAL NEEDED

Order the following kit:

Part No.	Description	Qty
660699	DRAG LINK ASSEMBLY	1
502104	COTTER PIN 5/32X2	2
IS-13009	INSTRUCTION SHEET	1
FI-13009	FEUILLE D'INSTRUCTIONS	1

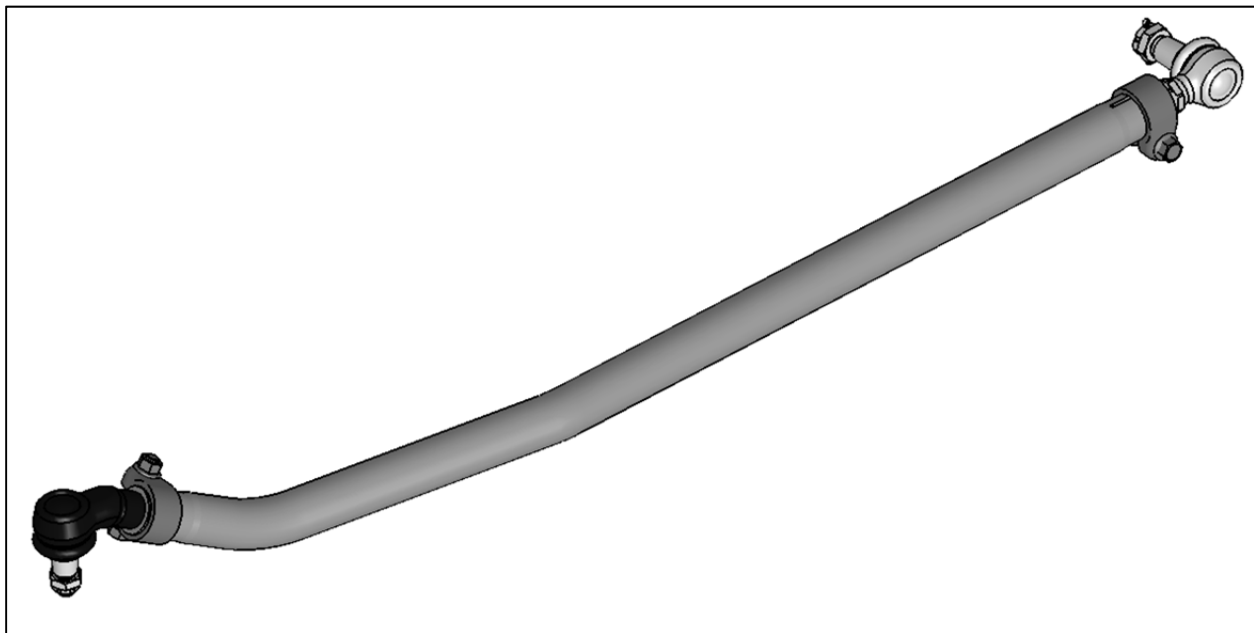

PART NO 660699

NOTE

Material can be obtained through regular channels.

PROCEDURE



DANGER

Park vehicle safely, apply parking brake, stop engine. Prior to working on the vehicle, set the ignition switch to the OFF position and trip the main circuit breakers equipped with a trip button. On Commuter type vehicles, set the battery master switch (master cut-out) to the OFF position.

Date	Expiration	Release	Page
03.2018	03.2019	4	3(11)

PRECAUTIONS



PINCH HAZARD

Keep hands and fingers clear of pinch zones around pitman arm.

Pinch zones are between pitman arm and clamp, and between front of pitman arm and vehicle structure.

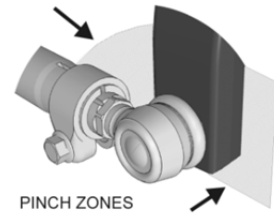

REMOVAL OF EXISTING DRAG LINK

1. Raise the vehicle by the wheels using mobile column lifts. Doing so will prevent a change in direction of the knuckles and preserve the relative positions of the steering components involved in this procedure.
2. Remove cotter pin and nut from drag link ball joint stud at pitman arm.
3. Disconnect drag link from pitman arm, using jaw style pullers (pressure screw type).



CAUTION

Heating of components to aid in disassembly is not allowed because it has a detrimental effect on axle components and steering linkages.

4. Remove cotter pin and nut from drag link ball joint stud at the steering arm (near knuckle) and then disconnect the drag link.

ADJUSTING THE DRAG LINK TO PROPER LENGTH - ELBOW BALL JOINT (KNUCKLE SIDE)

5. Check if the pre-adjusted length of the drag link is correct. To do so, try to install it between the steering arm and the pitman arm. If the length is not adequate, it must be adjusted to the required length. Use dimension "A" to adjust the length of the replacement drag link or you may use the replaced drag link for length reference.

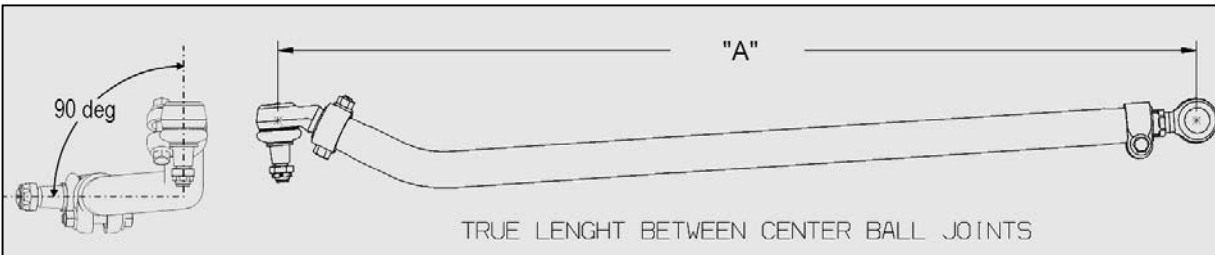

FIGURE 1

X3 series

length A = 52" 3/8" ± 1/16" (1330mm ± 2mm)

H3 series early model years (see MODEL YEAR(S) AND VEHICLES INVOLVED table)

length A = 52" 3/8" ± 1/16" (1330mm ± 2mm)

H3 series late model years (see MODEL YEAR(S) AND VEHICLES INVOLVED table)

length A = 53" 3/8" ± 1/16" (1356mm ± 2mm)

6. Screw the drag link elbow ball joint (knuckle side) fully in drag link tube.



FIGURE 2

Date	Expiration	Release	Page
03.2018	03.2019	4	5(11)

X3 AND EARLY MODEL YEARS H3 ONLY

7. Unscrew the drag link elbow ball joint back out (**not more than 1 turn**) so the tapered shank points down as shown on FIGURE 1.



FIGURE 3

X3 AND EARLY MODEL YEARS H3 ONLY

8. Unscrew the drag link elbow ball joint back out **one (1) full turn**. The tapered shank must point down as shown on FIGURE 1.

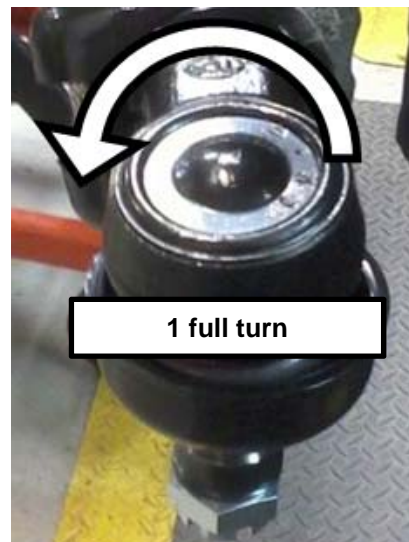

FIGURE 4

LATE MODEL YEARS H3 ONLY

The limits of the adjustment sleeve do not provide enough extension.

- Unscrew the drag link elbow ball joint out **1 inch**. The tapered shank must point down as shown on FIGURE 1.

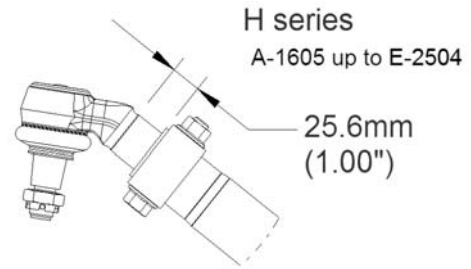

FIGURE 5

- To prevent interference between the ball joint clamp bolts and other components of the steering system, the clamp bolt must be positioned vertically as shown on FIGURE 6. **Tighten the clamp nut to 118-133 lbf-ft.**



CAUTION

Do not re-use clamp hardware.

Bolt and nut should be replaced every time they are unscrewed. While assembling the clamp, make sure the bolt does not touch the drag link tube.

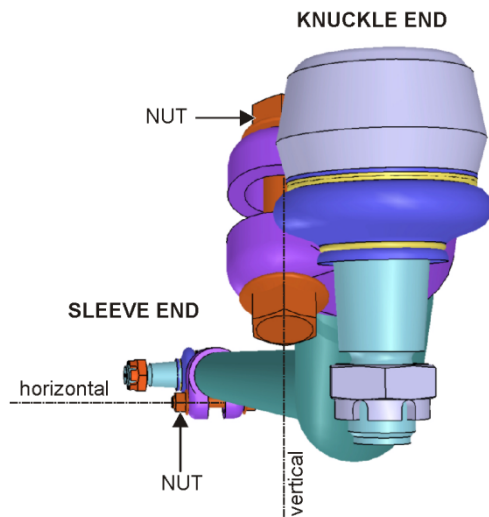
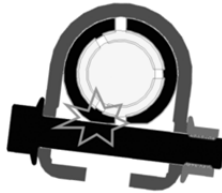

FIGURE 6: NOTE THE VERTICAL ORIENTATION OF THE CLAMP BOLT AT THE NUCKLE END AND ON WHICH SIDE THE NUT MUST BE POSITIONED

SLEEVE ADJUSTMENT PARAMETERS

- On the drag link front end you will find an adjustment sleeve which has internal and external left and right threads.

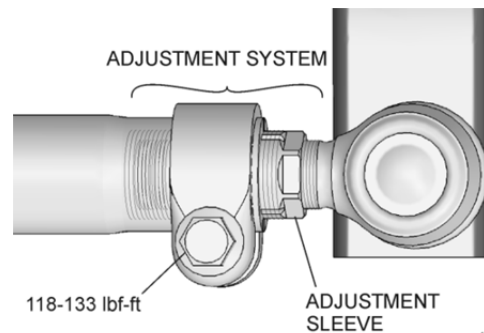

FIGURE 7

12. Fine adjustment of the drag link length if required should be performed exclusively by turning the adjustment sleeve while preventing the tube and joint from rotating.

The only part rotating should be the sleeve

- To extend, turn the sleeve clockwise.
- To retract, turn counter clockwise.

TURN ADJUSTMENT SLEEVE
COUNTER CLOCKWISE TO
REDUCE LENGTH

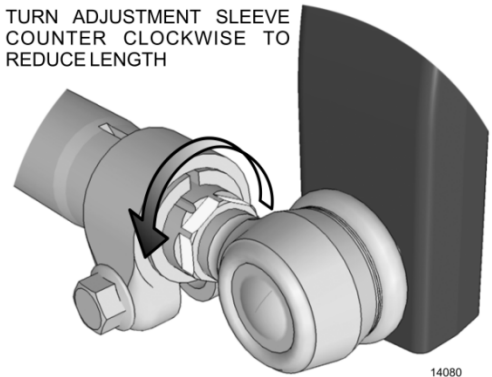

FIGURE 8

GENERAL LIMITATIONS OF THE ADJUSTMENT SLEEVE

Do not exceed the following maximum thread lengths and values.

- Max dimension **V** : 5/8" (16mm) ± 1 thread pitch
- Max dimension **W** : 5/8" (16mm) ± 1 thread pitch
- Max dimension **X** : 1" (25mm)
- Dimension **V** and **W** should be equal. ($V/W = 1$)

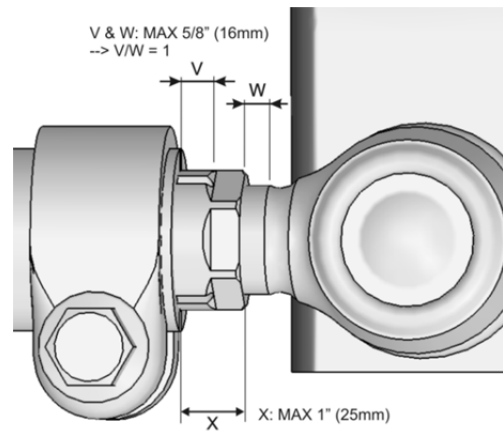

FIGURE 9

SLEEVE ADJUSTMENT

X3 AND EARLY MODEL YEARS H3 ONLY

13. Adjust sleeve to the values of FIGURE 10.
14. Once the proper length adjustment is done, tighten the front end ball joint clamp. To prevent interference between the ball joint clamp bolts with other components of the steering system, the clamp bolt must be positioned horizontally as shown on FIGURE 11. **Tighten the clamp nut to 118-133 lbf-ft.**

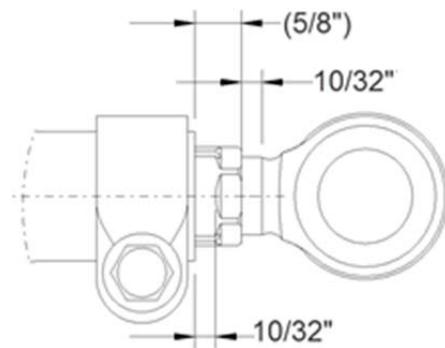

FIGURE 10

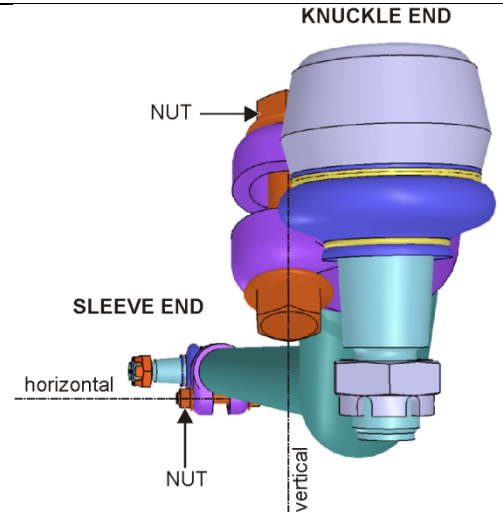

FIGURE 11: NOTE THE HORIZONTAL ORIENTATION OF THE CLAMP BOLT AT THE SLEEVE END AND ON WHICH SIDE THE NUT MUST BE POSITIONED

LATE MODEL YEARS H3 ONLY

15. Adjust sleeve to the values of FIGURE 12.
16. Once the proper length adjustment is done, tighten the front end ball joint clamp. To prevent interference between the ball joint clamp bolts with other components of the steering system, the clamp bolt must be positioned horizontally as shown on FIGURE 13. **Tighten the clamp nut to 118-133 lbf-ft.**

H series: A-1605 up to E-2504

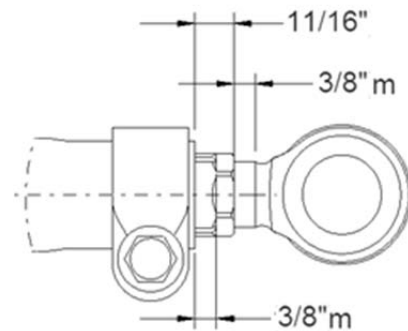

FIGURE 12

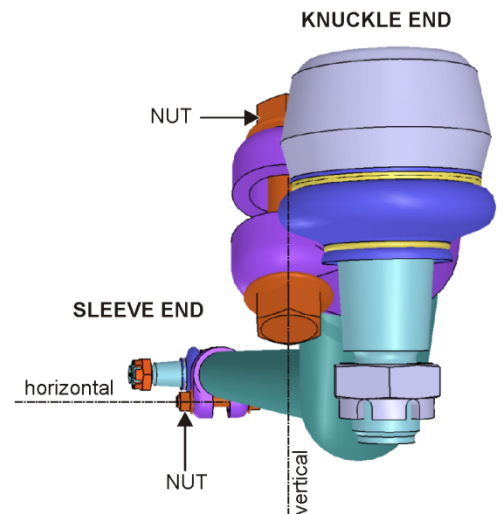

FIGURE 13: NOTE THE HORIZONTAL ORIENTATION OF THE CLAMP BOLT AT THE

Date	Expiration	Release	Page
03.2018	03.2019	4	9(11)

SLEEVE END AND ON WHICH SIDE THE NUT
MUST BE POSITIONED

DRAG LINK INSTALLATION

17. Install the drag link.
18. Ball joint castellated nut on both ends should be tightened to **150-200 lbf-ft**.
19. Install cotter pin **p/n 502104** and bend to lock bolt in place (see an example of a correct installation of a cotter pin on the image below).
20. Apply a small amount of anti-seize compound on all exposed threads for corrosion protection. Be sure to avoid smearing the ball joint boot.

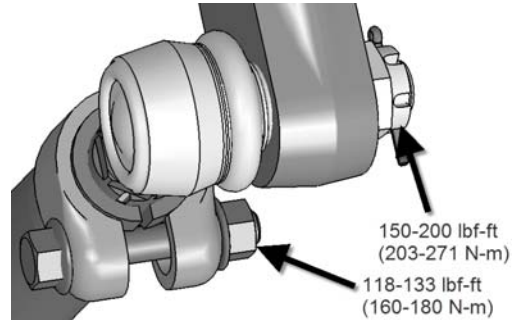
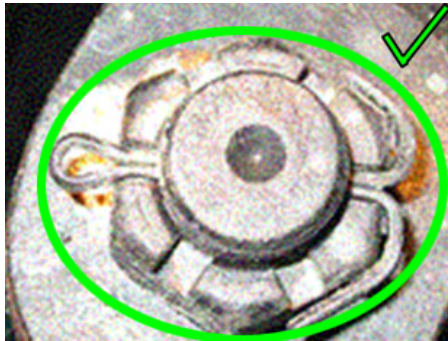

FIGURE 14



21. **VERY IMPORTANT.** The old drag links are subject to analysis and therefore, must be returned to Prevost. Please, fill the **WARRANTY MATERIAL RETURN TAG** found on the last page and join to the returned part.

Date	Expiration	Release	Page
03.2018	03.2019	4	10(11)

PARTS DISPOSAL

All replaced parts **must be returned to Prevest** according to the Return Shipping Instructions available on <https://www.prevestcar.com/content/warranty-documents> for full reimbursement.

WARRANTY

This modification is covered by Prevest's normal warranty. We will reimburse you the parts and 2 ½ hours (2.5) of labor upon receipt of the parts and a warranty claim. Please submit claim via our Online Warranty System, available at www.prevestcar.com (under Service \ Warranty section).

OTHER

VBC Bulletin	N/A
Fail Code	14.04
Defect Code	09
Syst. Cond	B
Causal Part	160932

Access all our Service Bulletins on <http://techpub.prevestcar.com/en/>
or scan the QR-Code with your smart phone.



Prevest engages in a continuous program of testing and evaluating to provide the best possible product. Prevest, however, is not committed to, or liable for updating existing products.

Date	Expiration	Release	Page
03.2018	03.2019	4	11(11)

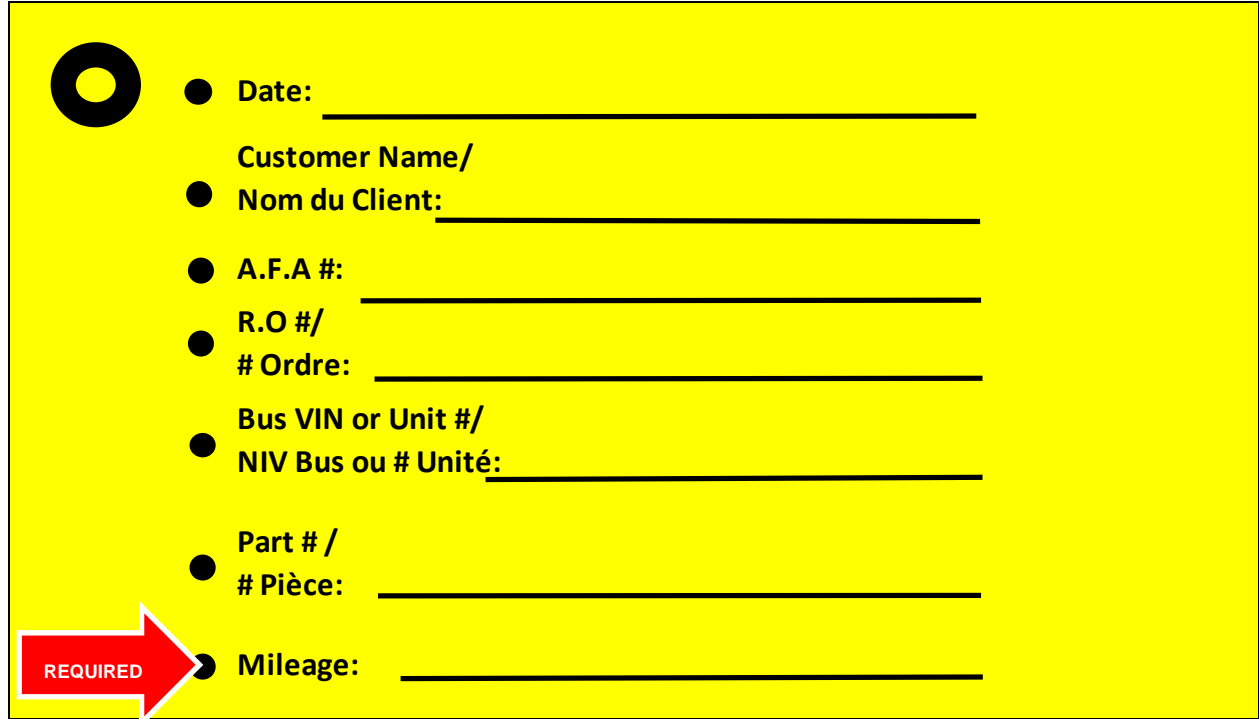

- Date: _____
- Customer Name/
● Nom du Client: _____
- A.F.A #: _____
- R.O #/
● # Ordre: _____
- Bus VIN or Unit #/
● NIV Bus ou # Unité: _____
- Part # /
● # Pièce: _____
- Mileage: _____



WARRANTY MATERIAL RETURN TAG Prevost, Nova Bus and Volvo 9700 brand buses	ÉTIQUETTE DE RETOUR DE MATÉRIEL SOUS GARANTIE Autobus de marques Prevost, Nova Bus et Volvo 9700
--	---

This tag is orderable free of charge at Prevost as part # **QF230237**
Cet étiquette peut être commandé sans frais chez Prevost - Pièce # **QF230237**

QF230237 rev 1