



# Technical Service Bulletin

---

## 38 Transmission cooler line leaks

38 18 12 2018289/5 March 12, 2018. Supersedes Technical Service Bulletin Group 38 number 10-04 dated August 11, 2010 for reasons listed below.

Model(s)	Year	VIN Range	Vehicle-Specific Equipment
Q7	2008	000001 – 024700	Not Applicable

## Condition

REVISION HISTORY		
Revision	Date	Purpose
5	-	Revised <i>Service</i> (Removed Technical Assistance Contact Requirement) Revised <i>Warranty</i> (Added Claim Types)
4	08/11/2010	Revised <i>Condition</i> (To correct typographical error)
3	06/15/2010	Revised header data (Corrected display issues in Elsa)

### Customer states:

- Transmission fluid leaking from automatic transmission cooler lines between gearbox and ATF cooler.
- Affects all Audi Q7 with an automatic gearbox (09D and 0AT).

## Technical Background

Seals in the area of the oil temperature regulator can be damaged due to burrs in the connection and may develop transmission fluid leaks.

## Production Solution

The radiuses of the connections were changed for the oil temperature regulator in production.



# Technical Service Bulletin

## Service

1. If there is leakage on the connections with the oil temperature regulator (no. 3/4/5/6), then please replace both the oil temperature regulator and the seals.
2. If the leakage is not in the area of the oil temperature regulator, please diagnose the location of the leak and this TSB does not apply.

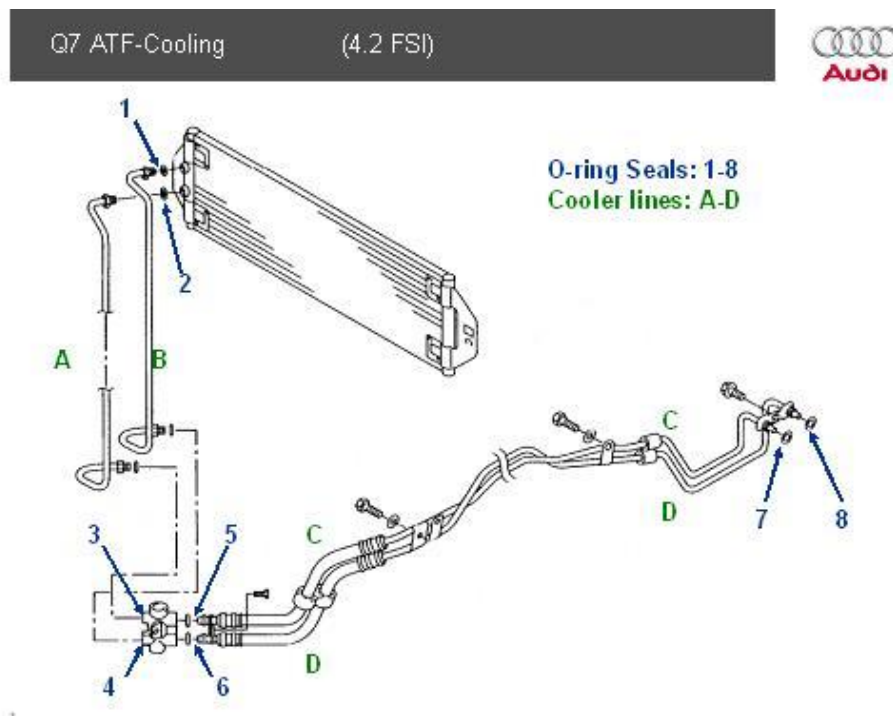
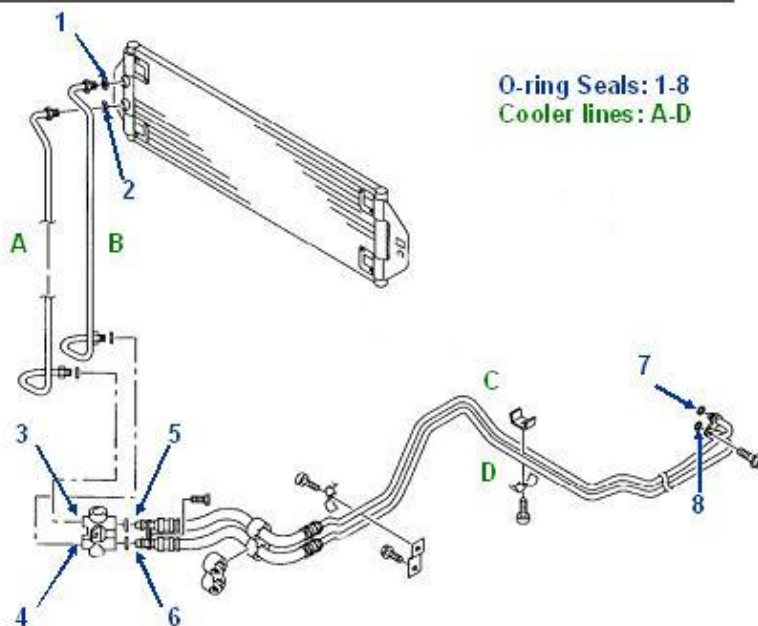

**Figure 1.** The ATF cooling lines of a 4.2L FSI Audi Q7.



# Technical Service Bulletin

Q7 ATF-Cooling (3.6FSI)



**Figure 2.** The ATF cooling lines of a 3.6L FSI Audi Q7.



# Technical Service Bulletin

---

## Warranty

<b>Claim Type:</b>	<ul style="list-style-type: none"><li>• 110 up to 48 Months/50,000 Miles.</li><li>• G10 for CPO Covered Vehicles – Verify Owner.</li><li>• If vehicle is outside any warranty, this Technical Service Bulletin is informational only.</li></ul>		
<b>Service Number:</b>	3862		
<b>Damage Code:</b>	0050		
<b>Labor Operations:</b>	Replace oil temperature regulator and seals	3862 5199	130 TU
	ATF inspect + add	3702 3550	30 TU
<b>Diagnostic Time:</b>	GFF	No allowance	0 TU
	Road test prior to service procedure	No allowance	0 TU
	Road test after service procedure	0121 0004	10 TU
<b>Claim Comment:</b>	As per TSB #2018289/5		

All warranty claims submitted for payment must be in accordance with the *Audi Warranty Policies and Procedures Manual*. Claims are subject to review or audit by Audi Warranty.

## Required Parts and Tools

Please use ETKA for the latest parts information for the VIN of the vehicle you are working on.

## Additional Information

All parts and service references provided in this TSB (2018289) are subject to change and/or removal. Always check with your Parts Department and service manuals for the latest information. Please check the Repair Manual for fasteners, bolts, nuts, and screws that require replacement during the repair.

©2018 Audi of America, Inc. All rights reserved. Information contained in this document is based on the latest information available at the time of printing and is subject to the copyright and other intellectual property rights of Audi of America, Inc., its affiliated companies and its licensors. All rights are reserved to make changes at any time without notice. No part of this document may be reproduced, stored in a retrieval system, or transmitted in any form or by any means, electronic, mechanical, photocopying, recording, or otherwise, nor may these materials be modified or reposted to other sites without the prior expressed written permission of the publisher.