



Maserati Technical Bulletin

Date: April 17, 2018
Bulletin No. MAS001520 – HVAC Actuator Software
Supersedes: MAS001332
Section: Heat / AC - S/W Updates

MASERATI

MODELS: Model Years 2014 through 2016, Quattroporte (M156) and Ghibli (M157)

SUBJECT: New HVAC Software to prevent sticking Actuators

DESCRIPTION

Maserati Quattroporte and Ghibli vehicles, from the start of production up to and including MY16, could intermittently experience one of the HVAC actuators getting stuck.

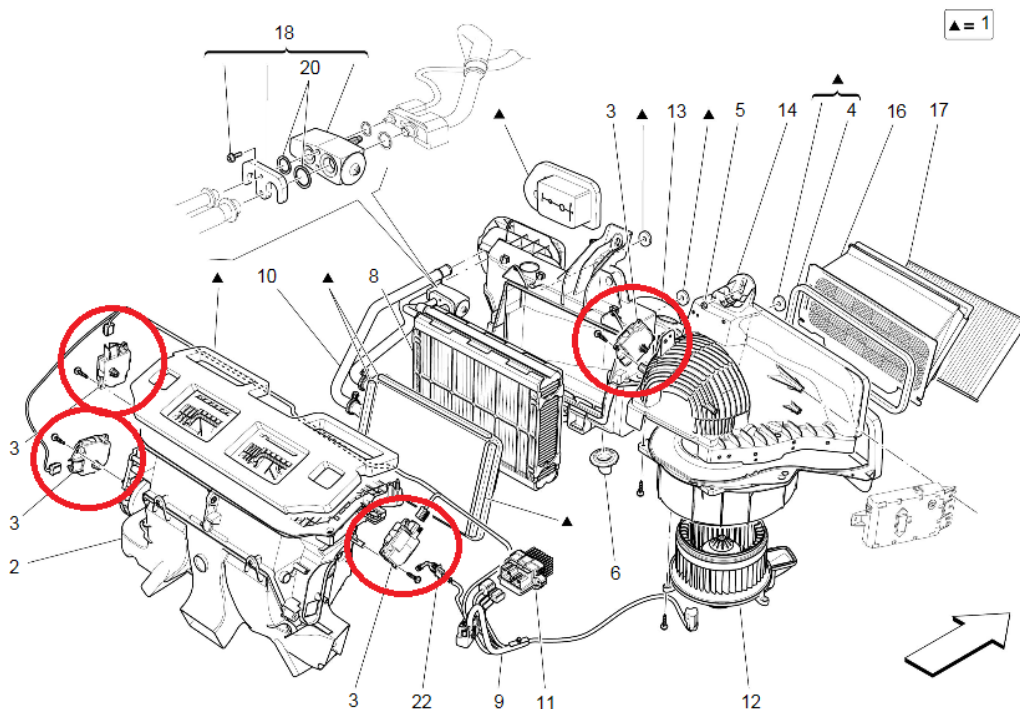

To resolve this issue, a new software version for the HVAC ECU is now available. The new software will improve the motor management for the air flow control actuators to help prevent them from getting stuck.

The new software version is 16.52.00 (or higher depending on production date).

MY17 and newer vehicles already have the latest software.

OPERATING PROCEDURE

1. Verify that the actuator(s) are not stuck in a fixed position.
2. If an actuator motor is stuck in a fixed position, do not replace the actuator, manually unlock it.
3. Next, connect the MD/MDEVO to the vehicle and perform the HVAC software update.
4. Finally, perform a functional test of the HVAC system to ensure that the air flow is directed as requested.
5. If the air flow is directed as requested, the procedure is complete.
6. If the air flow complaint is not resolved, open a BOL for a "Support Request" and wait for an approval before replacing an actuator.

WARRANTY INFORMATION

Downloading the S/W:

- Cost Code 16
- Defect Code 063
- Component Code 8.49.008
- Operation Code 8.49.008.9 (0.3h)

Nicola Rosciano
Manager Technical Support
Maserati North America, Inc.

Luis Sanchez
Technical Director
Maserati North America, Inc.