 <b>HYUNDAI</b> <b>Technical Service Bulletin</b>	GROUP	NUMBER
	<b>AUTOMATIC TRANSMISSION</b>	<b>18-AT-006</b>
	DATE	MODEL
	<b>APRIL, 2018</b>	Accent (RB/HC), Azera (TG/HG), Elantra (UD/MD/GD/JK/AD/PD), Kona (OS), Santa Fe (CM/AN/NC), Sonata (YF/YF HEV/LF/LF HEV/PHEV), Tucson (LM/TL), Veloster (FS)
<b>SUBJECT:</b>	<b>AUTOMATIC TRANSAXLE SHIFT LEVER DIAGNOSIS (6-SPEED)</b>	

***This TSB supersedes 16-AT-006-1 to add 2017~19 models.***

**Description:** The shift lever on some 6-speed vehicles may intermittently not shift out of Park. This bulletin provides the diagnostic procedures to correct this condition.

<b>Applicable Vehicles</b>	
2012~17	Accent (RB)
2018~	Accent (HC)
2011	Azera (TG)
2012~17	Azera (HG)
2011~16	Elantra (MD/UD)
2017~	Elantra (AD/ADa) 2.0L
2013~14	Elantra Coupe (JK)
2013~ 17	Elantra GT (GD)
2018~	Elantra GT (PD) 2.0L
2018~	Kona (OS) 2.0L
2010~12	Santa Fe (CM)
2013~18	Santa Fe Sport (AN)
2013~	Santa Fe (NC)
2011~14	Sonata (YF)
2015~	Sonata (LF) 2.0T/2.4L
2011~15	Sonata Hybrid (YF HEV)
2016~	Sonata Hybrid (LF HEV/PHEV)
2010~15	Tucson (LM)
2016~	Tucson (TL) 2.0L
2013~15	Veloster Turbo (FS)

**SUBJECT: AUTOMATIC TRANSAXLE SHIFT LEVER DIAGNOSIS (6-SPEED)****Parts Information:**

Model	Engine	Shift Lever	BCM or IPM
2012~17 Accent (RB)	1.6L	46700-*****	95400-*****
2018~ Accent (HC)	1.6L	46700-*****	95400-*****
2011 Azera (TG)	3.3L/3.8L	46700-*****	95400-*****
2012~17 Azera (HG)	3.3L	46700-*****	95400-*****
2011~16 Elantra (MD/UD)	1.8L	46700-*****	95400-*****
2017~ Elantra (AD/ADa)	2.0L	46700-*****	95400-*****
2013 Elantra Coupe (JK)	1.8L	46700-*****	95400-*****
2014 Elantra Coupe (JK)	2.0L	46700-*****	95400-*****
2013 Elantra GT (GD)	1.8L	46700-*****	95400-*****
2014~17 Elantra GT (GD)	2.0L	46700-*****	95400-*****
2018~ Elantra GT (PD)	2.0L	46700-*****	95400-*****
2018~ Kona (OS)	2.0L	46700-*****	95400-*****
2010-12 Santa Fe (CM)	2.4L/3.5L	46700-*****	95400-*****
2013~18 Santa Fe Sport (AN)	2.0T/2.4L	46700-*****	95400-*****
2013~ Santa Fe (NC)	3.3L	46700-*****	95400-*****
2011~ 14 Sonata (YF)	2.0L/2.4L	46700-*****	95400-*****
2015~ Sonata (LF)	2.0T/2.4L	46700-*****	95400-*****
2011~15 Sonata Hybrid (YF HEV)	2.4L	46700-*****	95400-*****
2016~ Sonata Hybrid (LF HEV/PHEV)	2.0L	46700-*****	95400-*****
2010~15 Tucson (LM)	2.4L	46700-*****	95400-*****
2011~15 Tucson (LM)	2.0L	46700-*****	95400-*****
2016~ Tucson (TL)	2.0L	46700-*****	95400-*****
2013~15 Veloster Turbo (FS)	1.6L Turbo	46700-*****	95400-*****

**NOTE:** The BCM for HG and FS is included in the Interior Junction Box or IPM Unit

**Warranty Information: Shift Lever**

Model	Op Code	Operation	Op Time	Causal Part	Nature Code	Cause Code
2012~17 Accent (RB)	43721R00	A/T change lever assembly	Refer to WEBLTS for current LTS time	See parts information	T33	ZZ3
2018~ Accent (HC)						
2011 Azera (TG)						
2012~17 Azera (HG)						
2011~16 Elantra (MD/UD)						
2017~ Elantra (AD/ADa) 2.0L						
2013~14 Elantra Coupe (JK)						
2013~ Elantra GT (GD)						
2018~ Elantra GT (PD) 2.0L						
2018~ Kona (OS) 2.0L						
2010~12 Santa Fe (CM)						
2013~18 Santa Fe Sport (AN)						
2013~ Santa Fe (NC)						
2011~14 Sonata (YF)						
2015~ Sonata (LF) 2.0T/2.4L						
2011~15 Sonata Hybrid (YF HEV)						
2016~ Sonata Hybrid (LF HEV/PHEV)						
2010~15 Tucson (LM)						
2016~ Tucson (TL) 2.0L						
2013~15 Veloster Turbo (FS) 1.6T						
All	43721RQ0	GDS				

**SUBJECT: AUTOMATIC TRANSAXLE SHIFT LEVER DIAGNOSIS (6-SPEED)**

**Warranty Information: Body Control Module (BCM) or IPM Unit/Interior Junction Box**

Model	Op Code	Operation	Op Time	Causal Part	Nature Code	Cause Code
2012~17 Accent (RB)	95415R00	Body control module				
2018~ Accent (HC)						
2011 Azera (TG)						
2012~17 Azera (HG)	91810R00	IPM Unit				
2011~16 Elantra (MD/UD)	95415R00	Body control module	Refer to WEBLTS for current LTS time	See parts information	T33	ZZ3
2017~ Elantra (AD/ADa) 2.0L						
2013~14 Elantra Coupe (JK)						
2013~17 Elantra GT (GD)						
2018~ Elantra GT (PD) 2.0L						
2018~ Kona (OS) 2.0L						
2010~12 Santa Fe (CM)						
2013~18 Santa Fe Sport (AN)						
2013~ Santa Fe (NC)						
2011~14 Sonata (YF)						
2015~ Sonata (LF) 2.0L/2.4L						
2011~15 Sonata Hybrid (YF HEV)						
2016~ Sonata Hybrid (LF HEV/PHEV)						
2010~15 Tucson (LM)						
2016~ Tucson (TL) 2.0L						
2013~15 Veloster 1.6L Turbo (FS)	91810R00	IPM Unit				

**NOTE:** BCM for HG and FS is included in the Interior Junction Box or IPM Unit.

**Service Procedure:**

1. If the symptom is “Key will not come out of the ignition”, refer to the ETM and check the voltage to the Key solenoid. If not, continue below.

Confirm the shift knob is fully installed on the shift lever by pushing down firmly on the shift knob.

- If not correctly installed, push the shift knob fully on the shift lever. The service is completed.
- If correctly installed, go to Step 2 and continue the diagnosis.



2. Turn the ignition key to the **ON** position or depress the Start/Stop Button two times and depress the brake pedal. Confirm the shift lever moves smoothly into all gear positions.

If not, remove the shift knob and press down on the white plastic rod.

- Moves out of Park, replace the shift knob.
- Does not move out of Park, reinstall the shift knob and go to Step 3.



3. Use the ignition key or a screwdriver to engage the shift-lock override. Move the shift lever through all gear positions to confirm that it operates properly.

- If the shift lever does not move out of Park, replace the shift lever.
- If the shift lever moves out of Park, go to Step 4.



4. Attach a GDS and check for any DTCs in the “Automatic Transaxle” menu. **Record the DTCs and the descriptions.** Delete the DTCs. If any DTCs are found, refer to the appropriate shop manual and follow the repair procedure. Go to Step 5.

**SUBJECT: AUTOMATIC TRANSAXLE SHIFT LEVER DIAGNOSIS (6-SPEED)**

5. From the GDS home page, select **Data Analysis** and **A/T** menu and confirm proper operation of the following parameters.
- If OK, the brake switch and shift lever are currently operating correctly. Go to Step 6.
  - If not, refer to the table below for repair guidance.

Parameter	Proper Operation	If <b>NOT</b> Proper Operation
Brake Switch	<b>ON</b> when brake pedal is pressed	Go to Step 6.
Shift Lever Switch	<b>P</b> when in Park position	Go to Step 10 and replace the shift lever assembly.
Sports Mode Select	<b>ON</b> when the shift lever is moved to Sports Mode	
Sports Mode Up Switch	<b>ON</b> when the shift lever is moved up (+)	
Sports Mode Down Switch	<b>ON</b> when the shift lever is moved down (-)	

6. From the GDS home page, select **Data Analysis** and **BCM** menu and confirm proper operation of the following parameters.
- If OK, go to Step 7.
  - If not, refer to the table below for repair guidance.

Parameter	Proper Operation	If <b>NOT</b> Proper Operation
Brake switch	<b>ON</b> when brake pedal is pressed	Replace the brake switch.
ATM solenoid	<b>ON</b> when brake pedal is pressed	Go to Step 7.

7. Turn the ignition switch to the ON position and place the shift lever in P and N. Confirm the indicator lights in the dash cluster show the correct gear in P and N.
- If P and N are displayed, go to Step 8.
  - If P or N are not displayed, check the alignment of the inhibitor switch according to TSB 17-AT-005. Replace the inhibitor switch if the adjustment is correct.
  - If P and N are not displayed after inhibitor switch adjustment, go to Step 8.



8. Check the TCU and TCU2 fuse in the junction box in the engine compartment:
- Check the fuse for an open circuit.
  - Check the fuse for correct capacity.
  - Check the fuse holder for a tight fit.
  - Check for loose or damaged wires.

If damage or an open circuit is found, repair or replace the junction box (PNC 91-912).

For Elantra (UD/MD), replace the EMS Block (91951-3X100) and retest.

If no damage or open circuit is found, go to Step 9.

9. Attach GDS Mobile and select **Data Analysis**, VIN and **Cluster** menu. Confirm the GDS indicates **Battery Voltage on CLU** is above 12v. If not, check for an open circuit.

For Elantra UD/MD/GD/JK only: Confirm the **P Inhibit Output** is ON:

- If ON: Go to Step 10.
- If OFF: Check the cluster for the cause of the condition or exchange the cluster from a known good vehicle. Replace the cluster, if necessary (PNC 91-940).

10. Use a plastic trim tool to remove the garnish.

Remove the shift knob and center console cover to gain access to the shift lever.

11. Move the shift lever to Park and turn the ignition switch ON. Depress the brake pedal and monitor the shift lock solenoid to determine if the solenoid releases the shift lever from Park. If the solenoid:
- Releases the shift lever, go to Step 12.
  - Does not release the shift lever, replace the shift lever.

Proper Gap Between Terminals



Loose Fit Between Fuse terminals

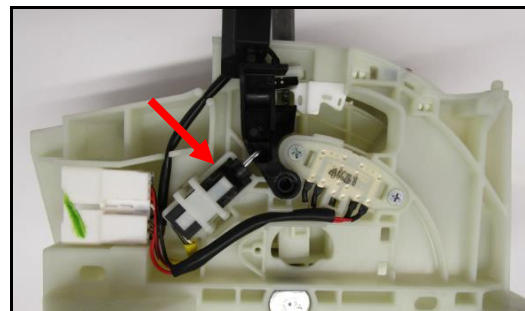
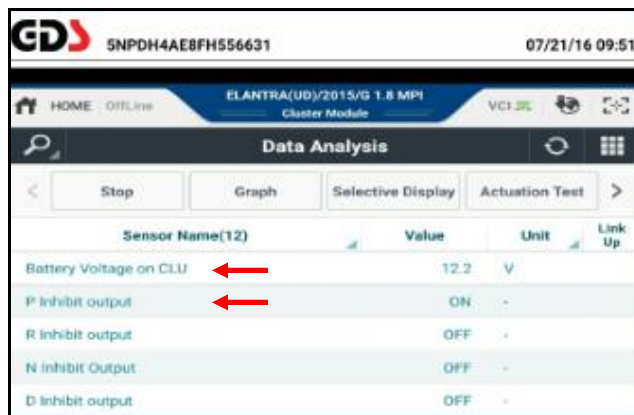

# SUBJECT: AUTOMATIC TRANSAXLE SHIFT LEVER DIAGNOSIS (6-SPEED)

12. Use a DVOM to test the circuit:
  - a. Check for 12V at the shift lock solenoid (A) – (See Step 14 diagram).
    - If not 12V, check the fuse and the harness from the fuse to the shift lock solenoid (A) for an open/short circuit. Repair as necessary.
    - If 12V, go to Step 12b.
  - b. Depress the brake pedal and check for 0V at the shift lock solenoid (B).
    - If 0V, the BCM is functioning correctly. Replace the shift lever (includes ATM solenoid).
    - If not 0V, go to Step 13.

13.
  - Refer to the shop manual and locate the BCM or IPM. Disconnect the connector to the BCM/IPM that provides ground for the shift lock solenoid (C).
  - Use a small pin to probe the harness side of the connector and connect to ground. If the shift lever:
    - Releases from Park, the solenoid and shift lever are functioning properly.
    - Does not release from Park: Inspect the harness between the shift lock solenoid (B) and BCM/IPM (C) for an open/short circuit. If OK, go to Step 14.



14. **For HG and FS:** Exchange the IPM Unit (IPS Control Module) from a known good vehicle and reconnect the connector. If the shift lever moves out of Park, replace with a new IPM.

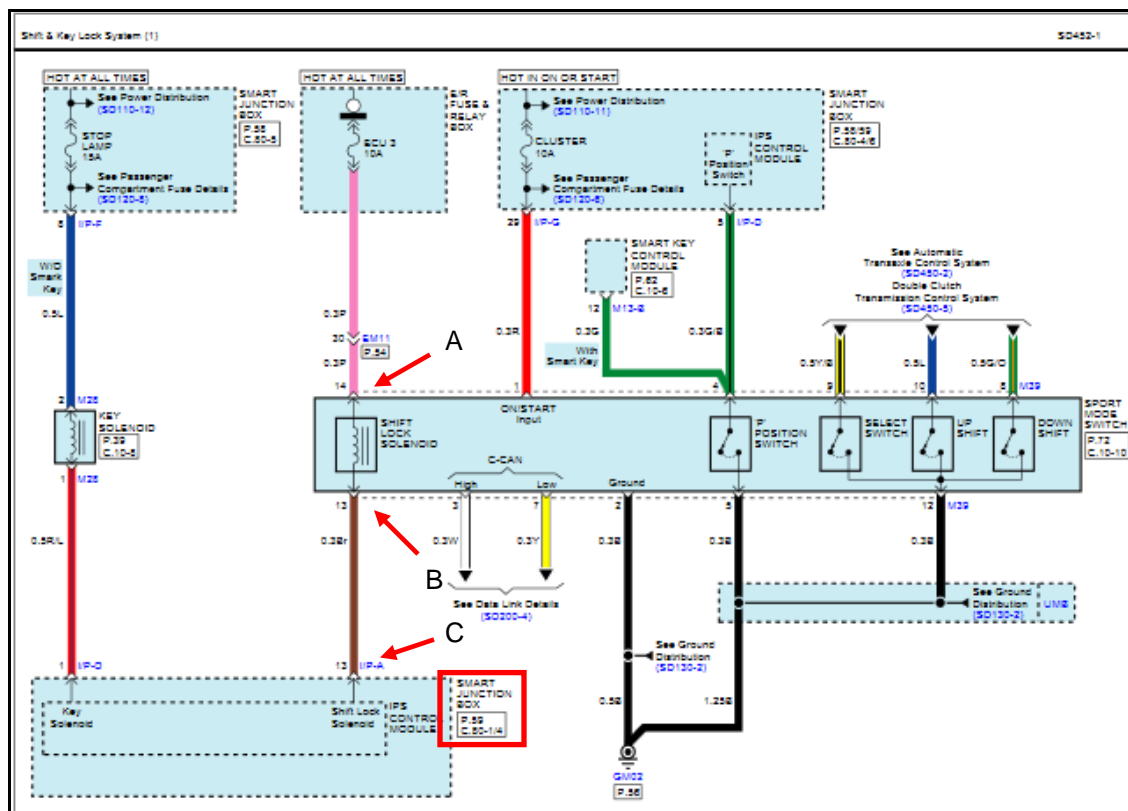



**For all other models:** Exchange a BCM from a known good vehicle and reconnect the connector. If the shift lever moves out of Park, replace with a new BCM.

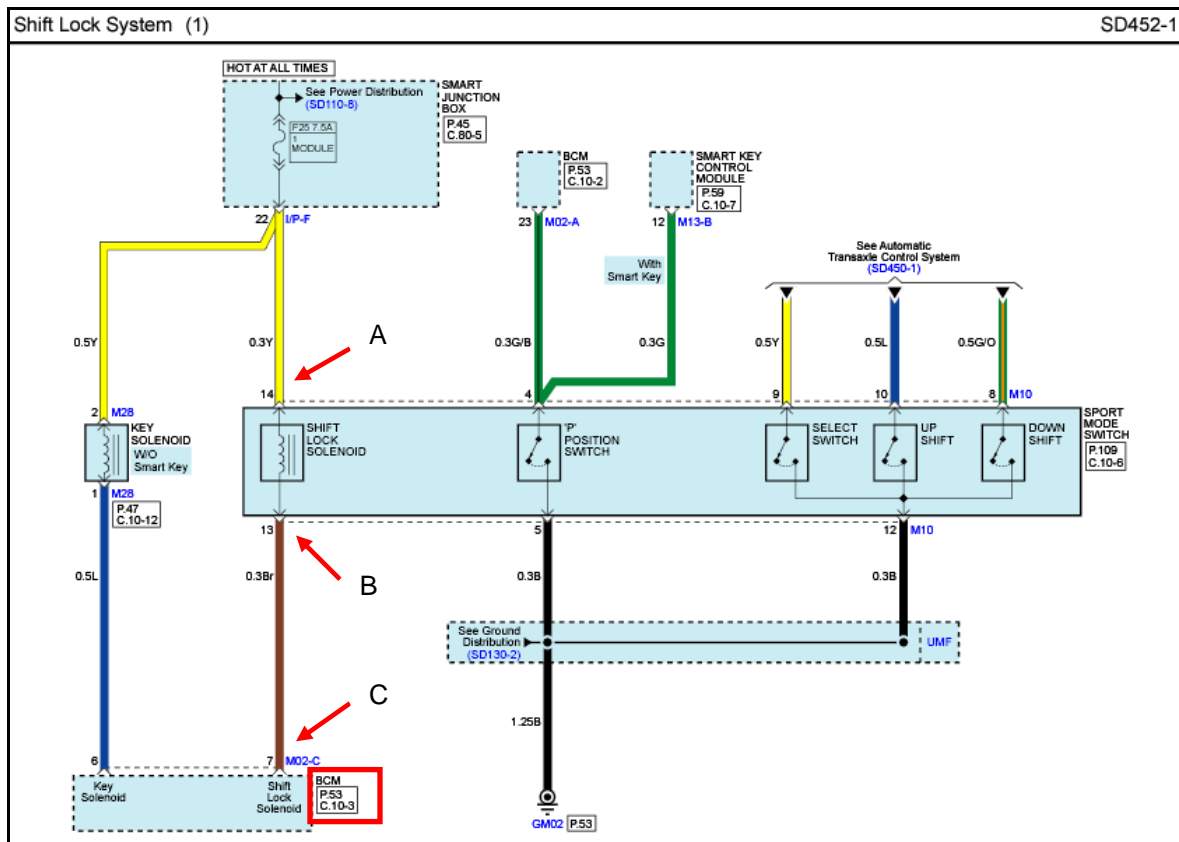

15. Reinstall the removed parts in the reverse order of removal.
16. Move the shift lever through all gear positions and confirm the shift lever and shift indicator lights function correctly.
17. Confirm the engine starts in Park and Neutral.