



Service Bulletin

File in Section: -

Bulletin No.: 16-NA-405

Date: February, 2018

TECHNICAL

Subject: Poor Engine Performance in Extremely Cold Weather Conditions, PCV Bypass Hose and Charge Air Cooler Icing for LUV Engines, Malfunction Indicator Lamp (MIL) Illuminated - DTC P0299, P0236, P2227, P00C7 Set

Attention: For vehicles that are out of warranty and are identified on the Applicable Warranties section in the GM Global Warranty Management system, refer to Special Coverage #17157.

Brand:	Model:	Model Year:		VIN:		Engine:	Transmission:
		from	to	from	to		
Buick	Encore	2013	2018			1.4L (LUV)	
Chevrolet	Trax						

Involved Region or Country	North America
Condition	<p>Some customers may comment that when driving short distances and/or slow speed driving cycles, their vehicle experiences one or several of the following conditions within the first 10 to 15 minutes of vehicle operation in extremely cold weather conditions (-18°C or less / 0°F or less):</p> <ul style="list-style-type: none"> • Loss of power. • Smoke out the tail pipe. • Hesitation on acceleration. • Stalling condition. • Burning oil odor possibly caused by oil leak. • May also notice a Malfunction Indicator Lamp illuminated. • After driving for a period of time, the driveability issues seem to diminish. • Malfunction Indicator Light Illuminated. <p>This condition may also cause an increase in crankcase pressure, creating oil leaks at seals and gaskets.</p> <p>The technician may find one or more of the following DTCs set:</p> <ul style="list-style-type: none"> • P0299 • P0236 • P2227 • P00C7
Cause	<p>This condition may be caused by one or more of the following:</p> <ul style="list-style-type: none"> • Plugged crank case vent tube from ice forming in the tube during very cold weather conditions. • Ice accumulation in the charge air cooler restricting air flow to the throttle body.
Correction	<p>Important: The PCV heater parts are only to be used in northern states or provinces that temperatures are -18°C or less / 0°F or less and for critical customers only.</p> <p>If any of the following conditions are validated to be caused by freezing/icing, installation of the following components are necessary:</p> <ul style="list-style-type: none"> • Heated PCV Bypass system • Modified Charge Air Cooler (CAC) <p>If not previously performed, an oil change may be necessary to remove any moisture from the engine. Prior to the oil change, run the engine at idle for an extended period of time to melt any ice in the engine.</p>

Important: If a fascia blocker was installed on the vehicle, it must be removed and discarded. A new fascia blocker will no longer need to be installed on the vehicle.

PCV Heater Service Procedure

Notice: The PCV Heater may have been installed previously onto the vehicle. If the PCV heater has been installed, proceed to step 36.

1. Operate the vehicle until it reaches operating temperature.
2. Remove the battery. Refer to *Battery Replacement* in SI.
3. Remove the engine cover.

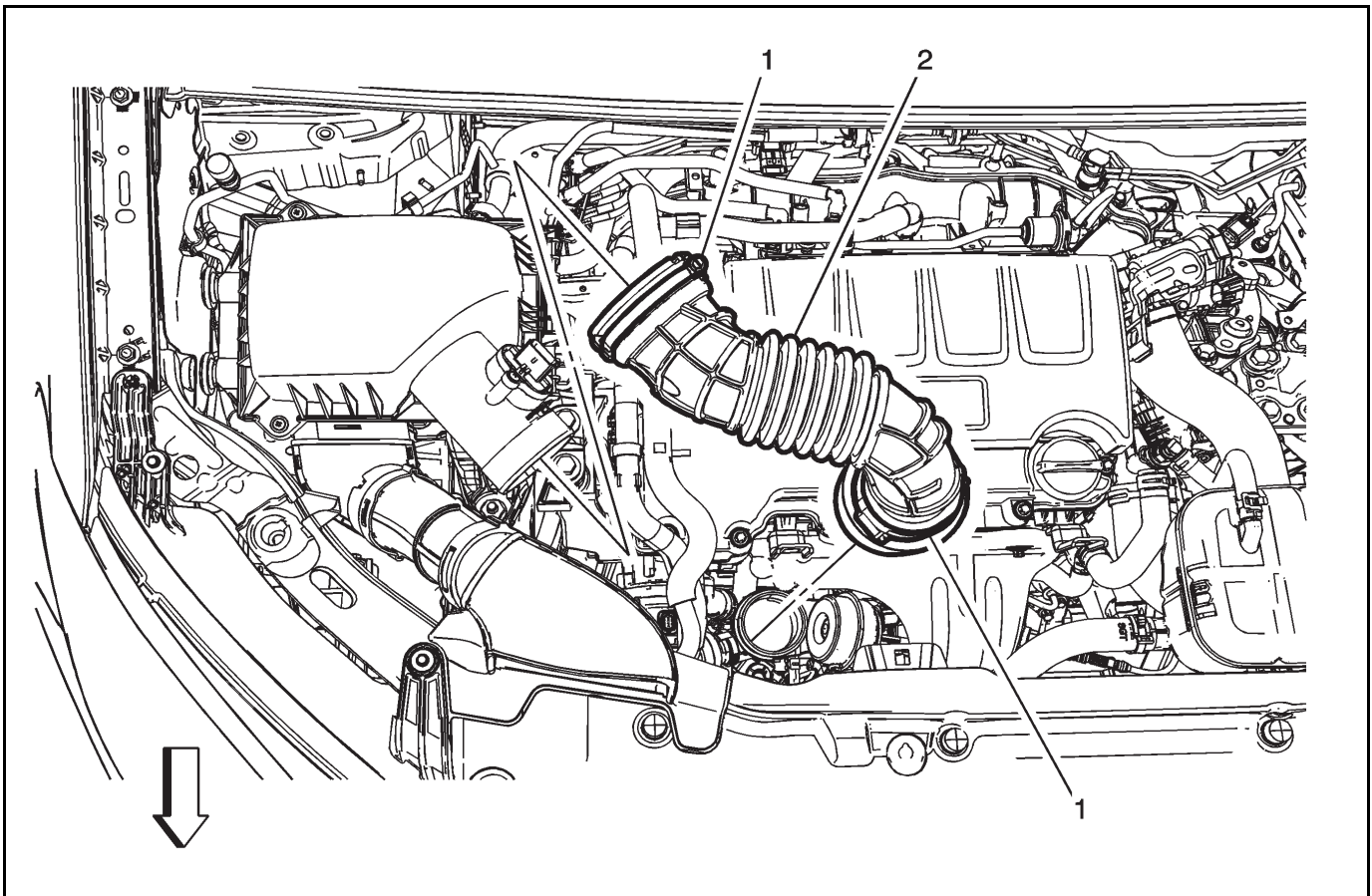

4. Remove and discard the air cleaner outlet duct (2) and resonator assembly.

Caution: **DO NOT** remove the vacuum hose from the vehicle unless the vacuum hose shows apparent signs of damage. Part damage may occur when attempting to disconnect the vacuum hose.

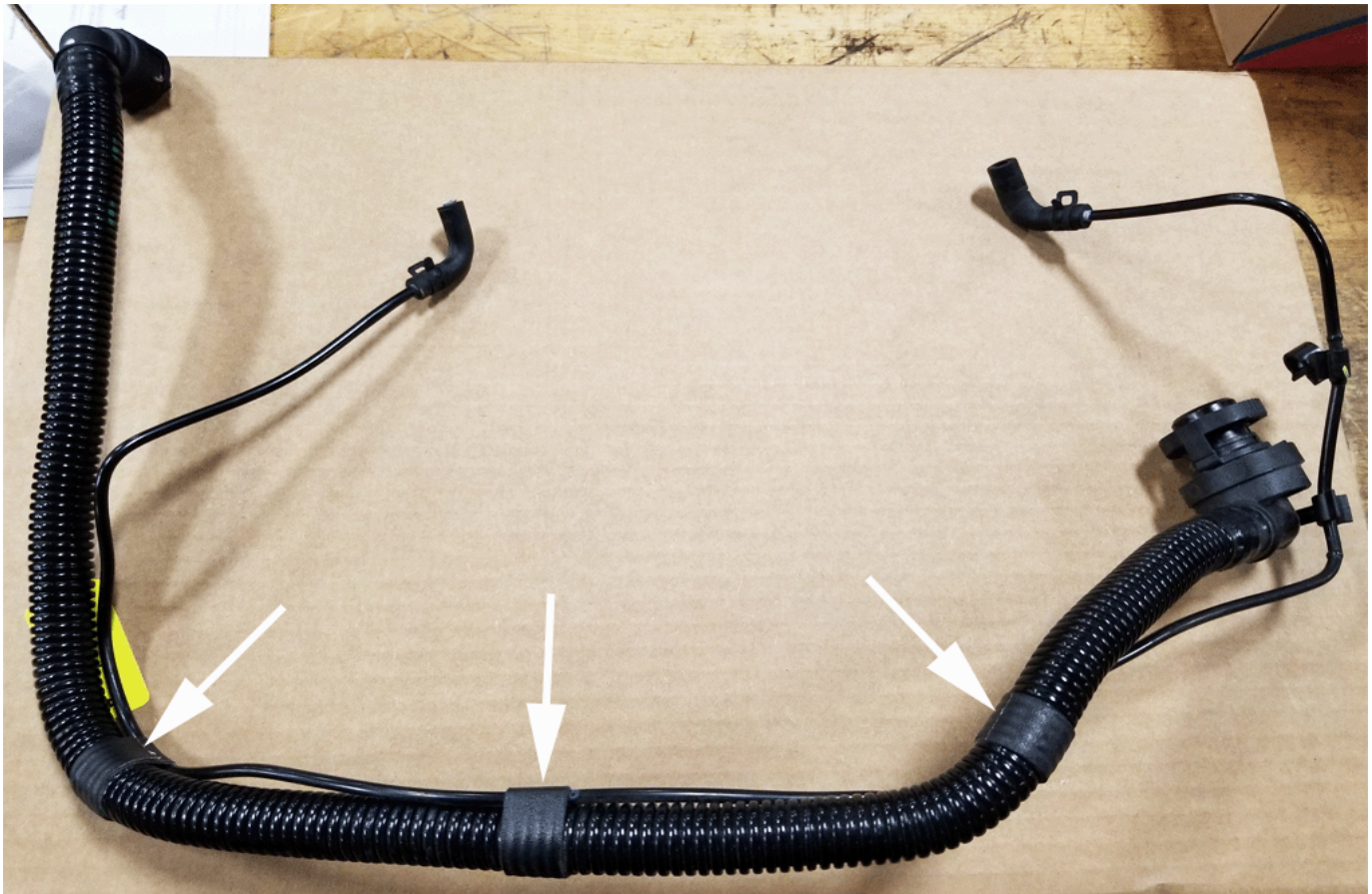

4855374

5. Using care, cut and remove the tape that secures the vacuum line to the Positive Crankcase Ventilation (PCV) Hose/Pipe/Tube.

6. Remove and discard the PCV Hose/Pipe/Tube (1) leaving the vacuum line. Refer to *Positive Crankcase Ventilation Hose/Pipe/Tube Replacement* in SI.

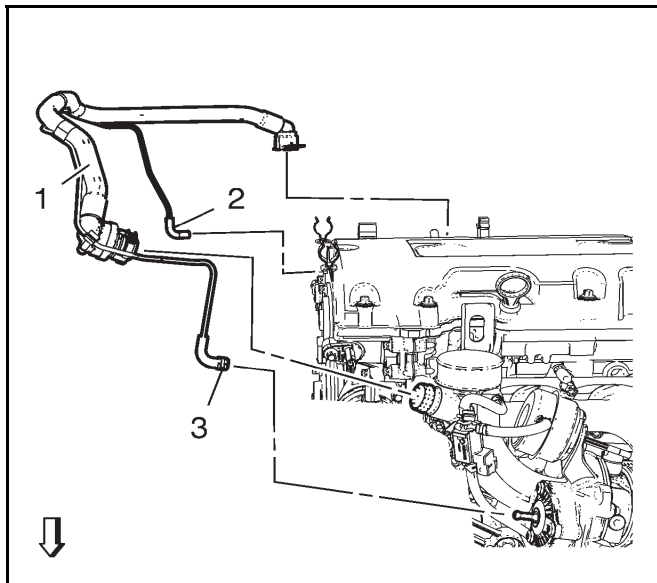

2191937

Note: Original PCV pipe with vacuum line attached removed from vehicle for illustrative purposes **ONLY**.

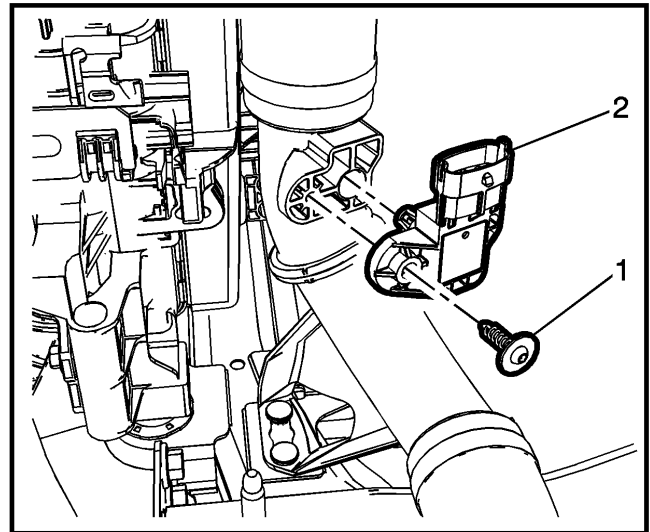
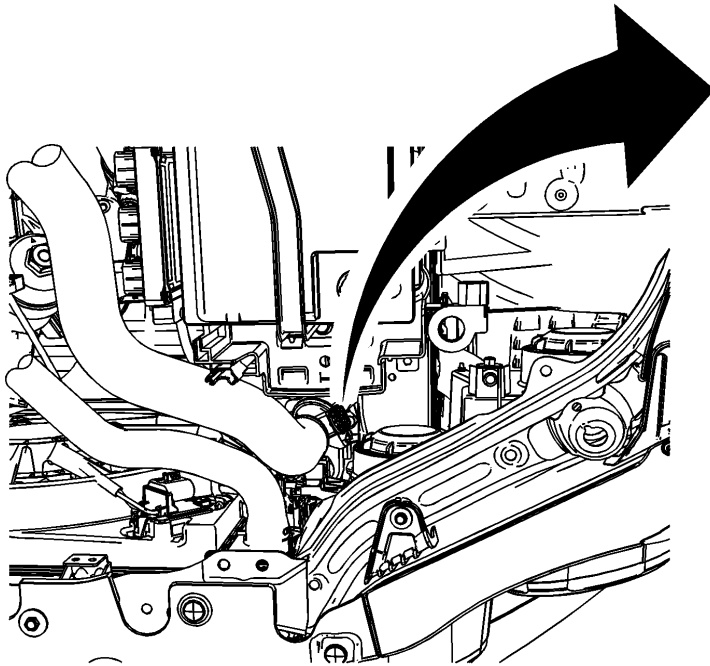

7. Remove the Intake Air Pressure and Temperature sensor (IAPT) (2). Refer to *Intake Air Pressure and Temperature Sensor Replacement* in SI.

4910635

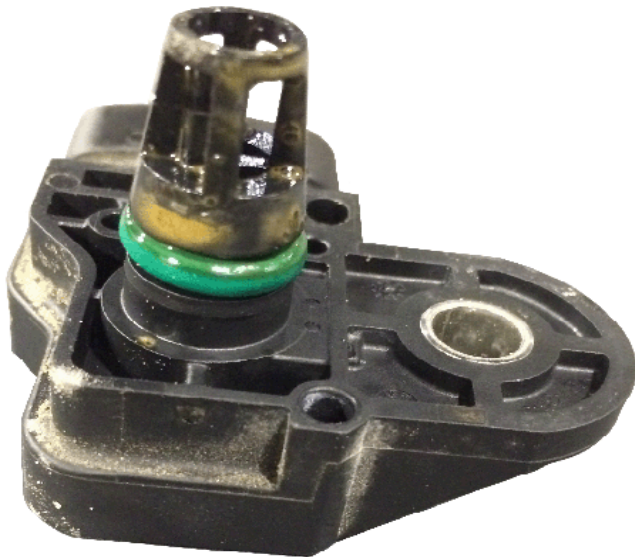

4910683

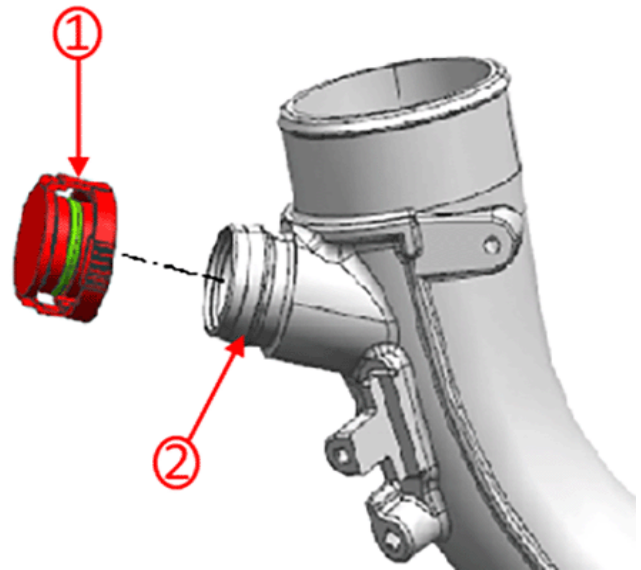

4377828

10. Install the block off plug (1) onto the turbocharger bypass port (2).

- 8. Inspect, clean and dry the IAPT sensor of any contaminates.
- 9. Install the IAPT sensor.

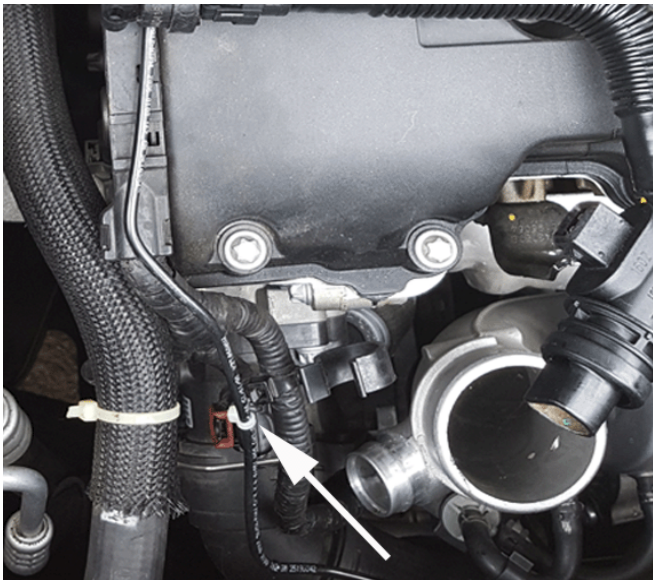

4855375

11. Using a tie strap, secure the vacuum line to the engine wiring harness.

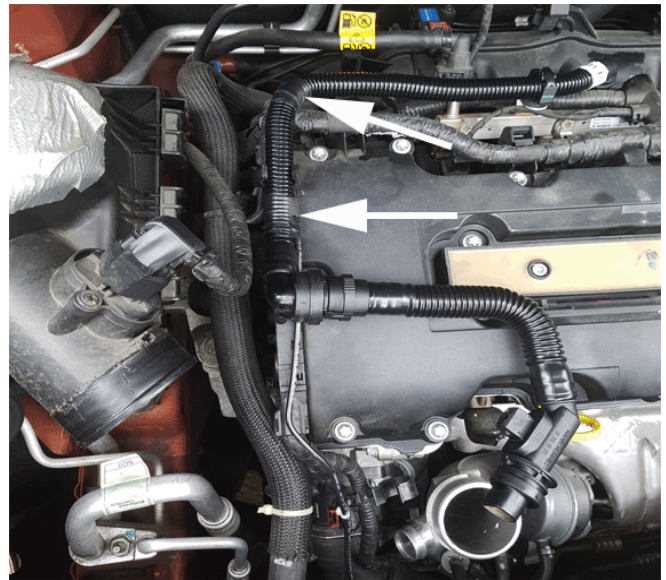

4855376

17. Using Woven Polyester Electrical Tape (PET), secure the vacuum line to the PCV pipe.

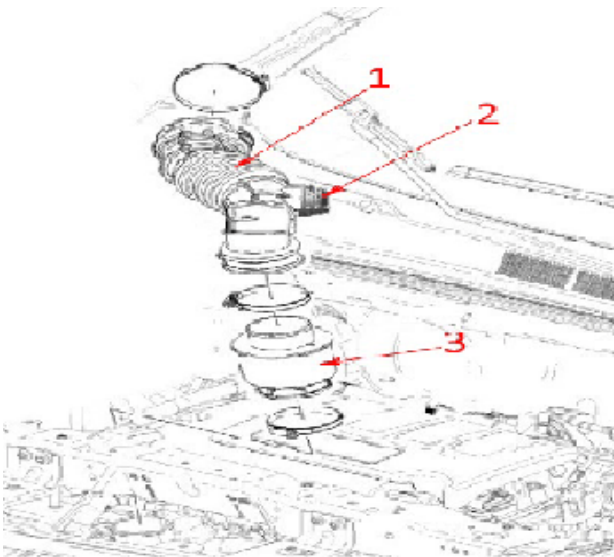

4418077

12. Install the new air cleaner outlet duct (1) and air resonator (3) assembly.
13. Using care, cut and remove the tape securing the vacuum line to the NEW PCV pipe.
14. Remove the vacuum line from the PCV pipe assembly.
15. Install the new PCV pipe assembly.
16. Install the PCV heater into air cleaner outlet duct (2).

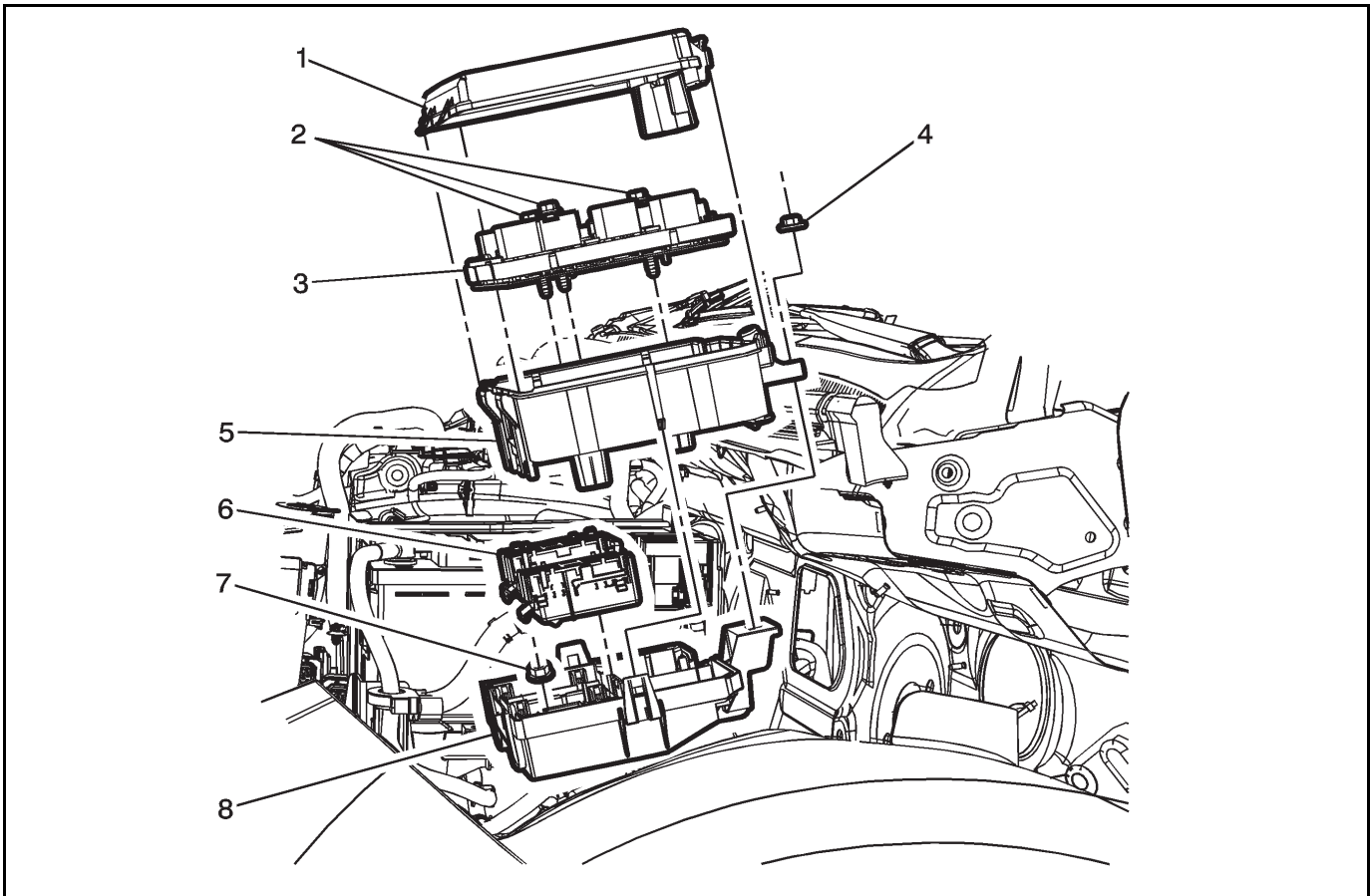

2760835

18. Remove the fuse block cover (1).
19. Remove the nut (4) that secures the upper fuse block to the body.
20. Loosen the three upper connector bolts (2).
21. Separate the upper (5) fuse block assembly from the fuse block base (8) by releasing the snap locks. Refer to *Front Compartment Fuse Block Replacement* in SI.
22. Route the PCV wiring harness under the battery tray.

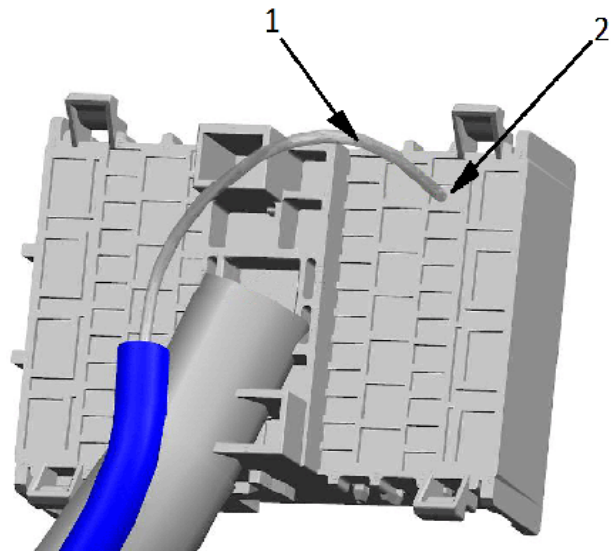

4377876

23. **For 2013-2016 model vehicles:**
 - 23.1. Remove UEX_X2 connector from the fuse block base.
 - 23.2. Remove connector cover.

23.3. Install PCV heater wiring harness terminal (1) into the J11 cavity (2).

⇒ Refer to X50A Fuse Block - Underhood X2 (Doc ID 4752878) in SI.

23.4. Route the wiring harness between the battery and fuse block.

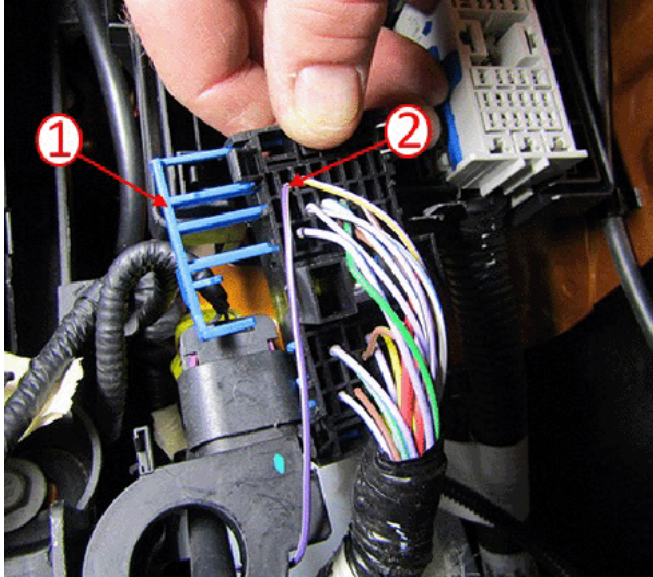

4598974

24. For 2017-2018 model vehicles:

24.1. Remove the UEX_X3 connector from the fuse block base.

24.2. Remove the connector cover.

24.3. Remove connector lock (1).

24.4. Install PCV heater wiring harness terminal into the H6 cavity (2).

⇒ Refer to X50A Fuse Block - Underhood X3 (Doc ID 4752879) in SI.

25. Using tie straps, fasten the PCV wiring harness to the connectors wiring harness at the white tape indicators.

26. Install the connector back onto the fuse block base.

Important: Only replace the fuse and install the labels on vehicles that have a 5 amp fuse. Some vehicles have the 10 amp fuse already installed and do not require replacement or the label.

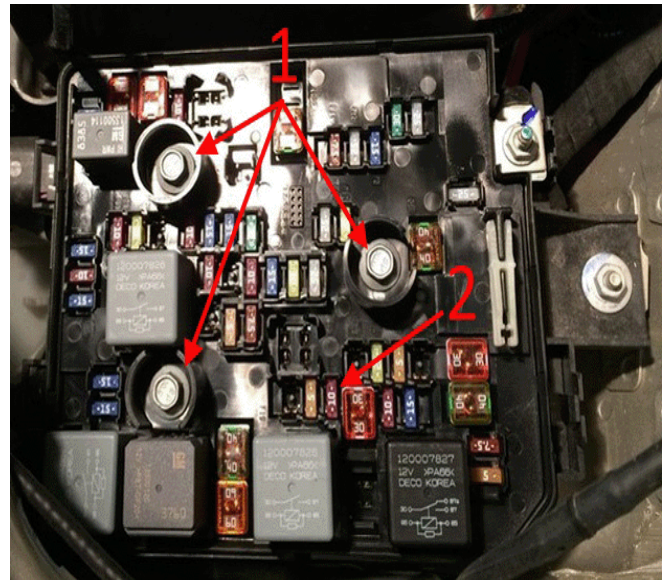

4379861

27. Position and snap the upper fuse block onto the base.

Tighten

Torque the bolts (1) to specifications. Refer to *Fastener Specifications* in SI.

28. If necessary, replace the 5 amp fuse with a 10 amp fuse into cavity F17 (2).

29. Install the front compartment fuse block cover.

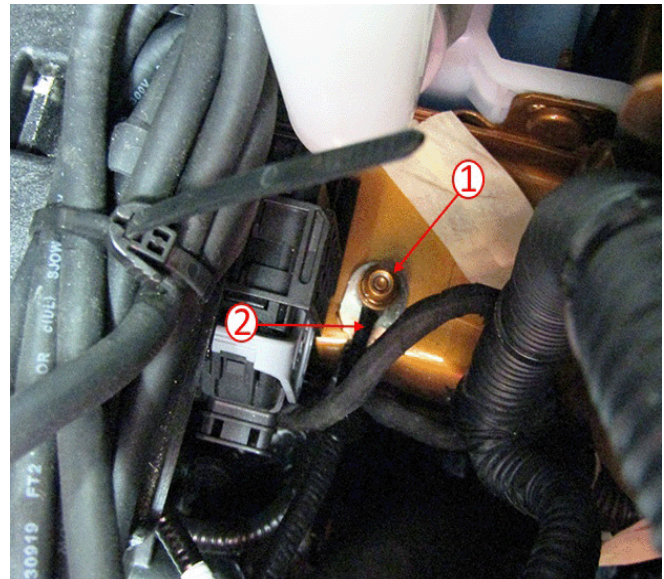

4605957

30. Install the PCV heater wiring harness ground wire (2) to ground G103 (1).

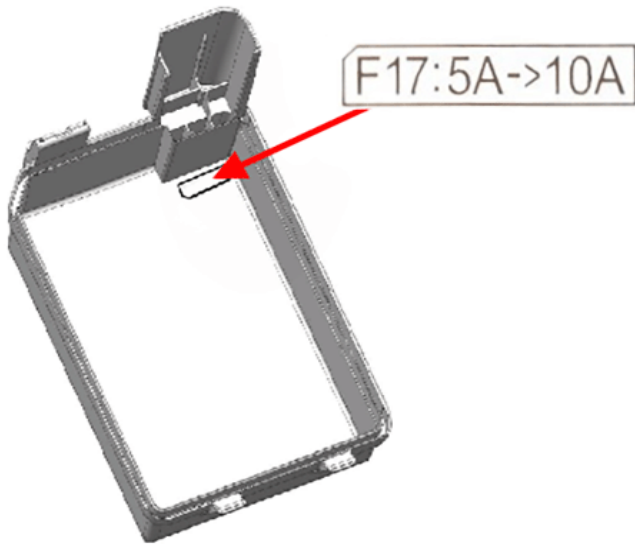

4379843

31. If necessary, install the UEC sticker onto the backside of the fuse block cover and in the owners manual under Engine Compartment Fuse Block.

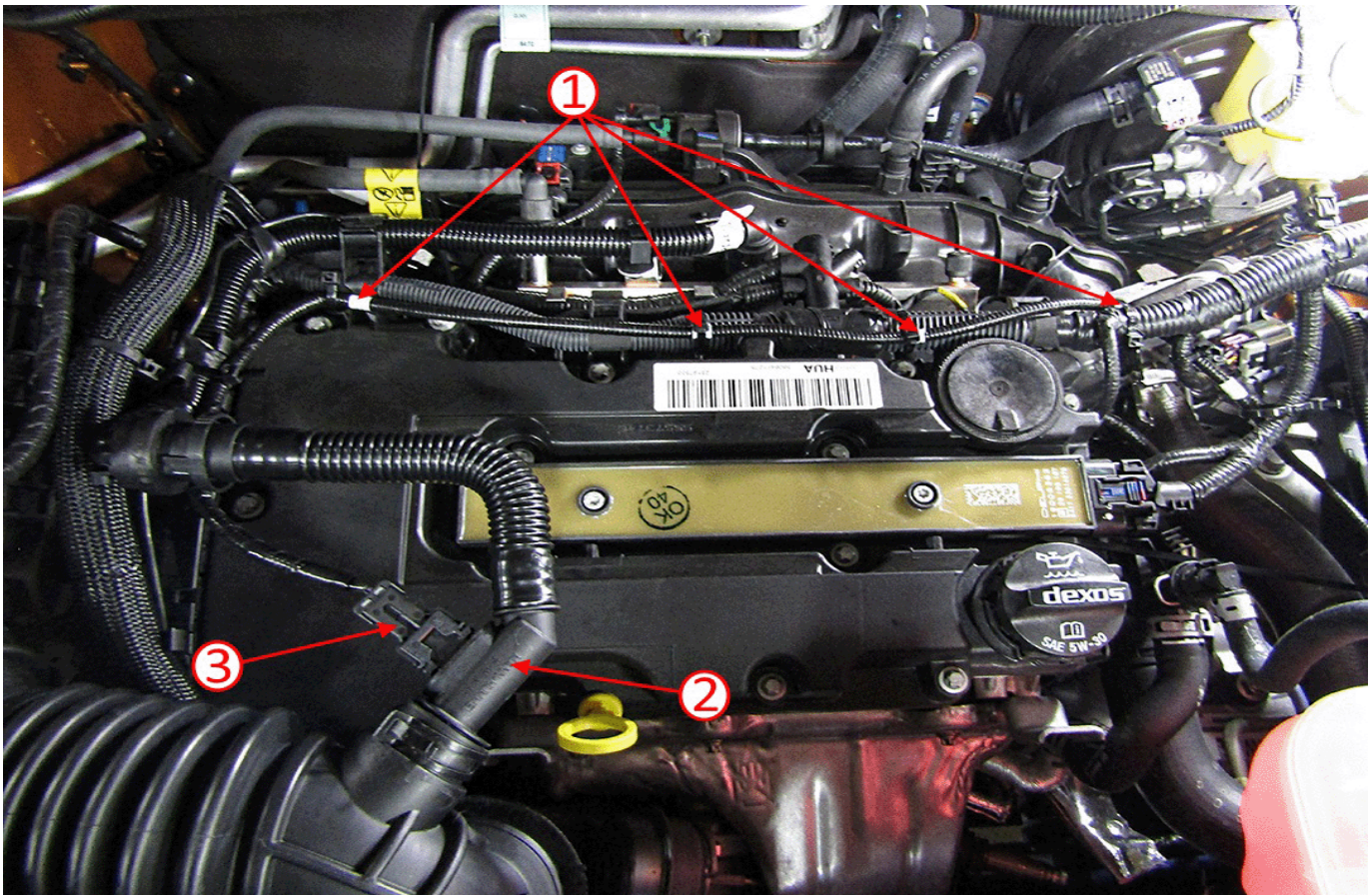

32. Route the PCV heater wiring harness across the engine wiring harness.
33. Using the tie straps, fasten the wiring harness at the white marking points (1).
34. Connect the electrical connector (3) to the PCV heater (2).

35. Install the battery.
36. Install engine cover.

4609442

Important: Do Not perform an oil change if the vehicle is returning for the CAC update and/or if the oil change was recently done.

- If the oil change was recently done, proceed to step 38.
- If the oil change was not previously done, proceed with procedure.

37. If required, perform an oil change. Refer to *Engine Oil and Oil Filter Replacement* in SI.

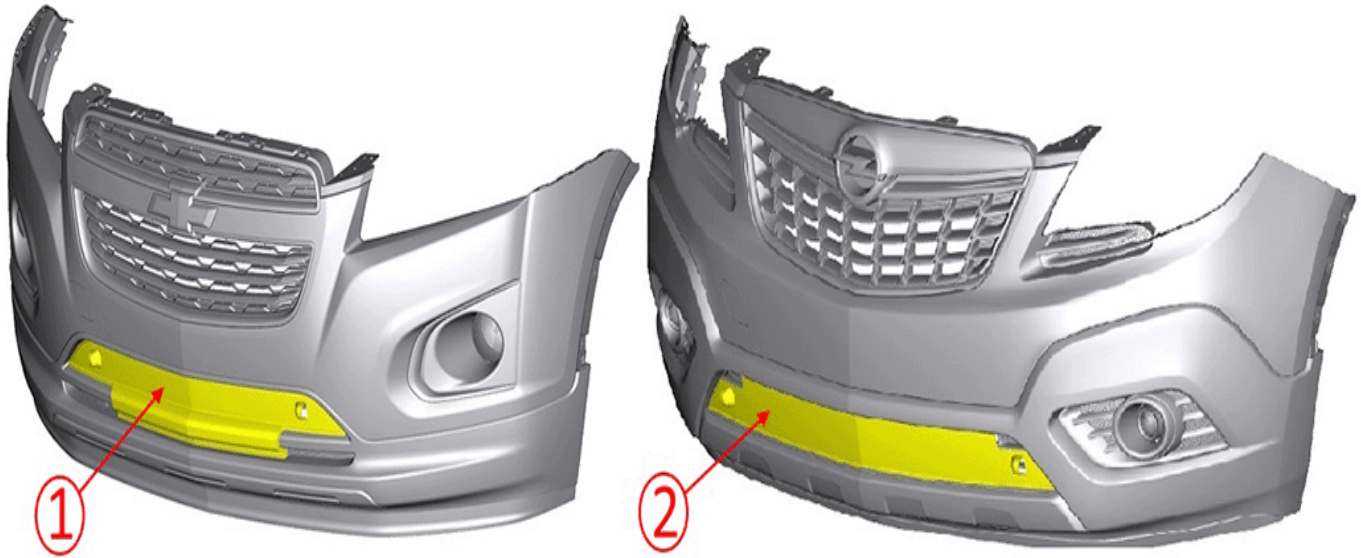

Important: If a fascia blocker was installed (1, 2) on the vehicle, it must be removed and discarded. A new fascia blocker will no longer need to be installed on the vehicle.

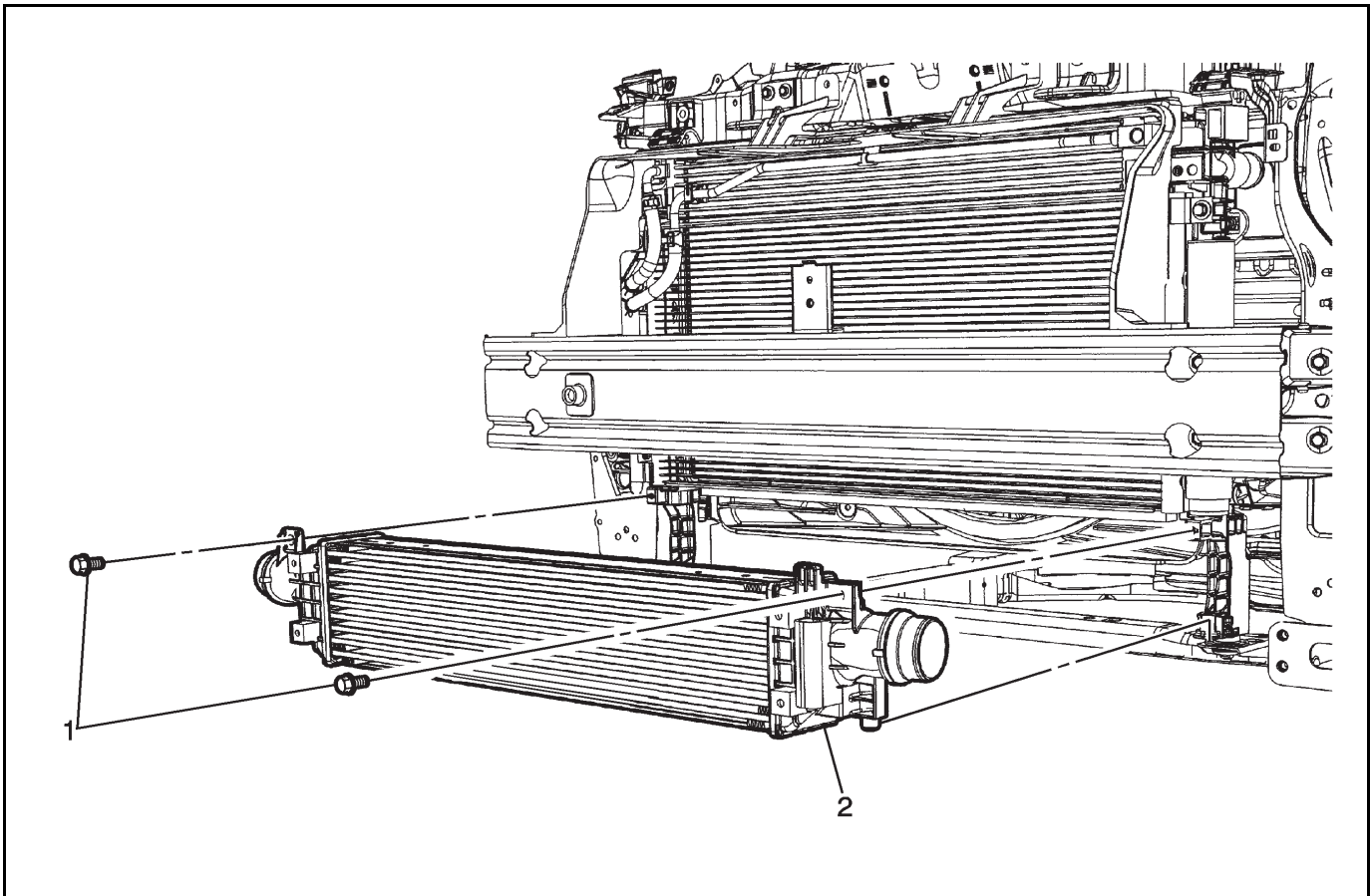

2851444

- 38. If installed, remove and discard the fascia blocker.
- 39. Remove the CAC (2). Refer to *Charge Air Cooler Replacement* in SI.
- 40. Install modified CAC.

Parts Information

Description	Model Year	Part Number	Qty
Kit, PCV Heater	2013-2016	25198125	1
Kit, PCV Heater	2017-2018	25198126	1
Cooler, Charge Air	2013-2018 (Encore, Trax)	42574031 (VIN pos 1 = K)	1
	2013-2018 (Trax)	42582747 (VIN pos 1 = 3)	1
Filter, Oil	2013-2018	Refer to the Electronic Parts Catalog (EPC).	
Oil			

Warranty Information

For vehicles repaired under the Powertrain coverage, use the following labor operation. Reference the Applicable Warranties section of Investigate Vehicle History (IVH) for coverage information.

Labor Operation	Description	Labor Time
4081358*	PCV Heater, Wiring Harness Installation and IAPT Inspection	1.2 hr
Add	Charge Air Cooler Removal	1.0 hr
Add	Fascia Blocker Removal	0.2 hr
Add	Oil Change	0.3 hr
*This is a unique Labor Operation for Bulletin use only.		

Version	7
Modified	<p>December 23, 2016 - Added DTCs to the Condition and a Note to the Parts Information.</p> <p>January 5, 2017 - Removed Fascia Blocker information.</p> <p>January 18, 2017 - Added draining the CAC.</p> <p>September 7, 2017 - Added fascia blocker removal information and added CAC part numbers.</p> <p>December 5, 2017 - Added RPO LUV to Subject, added the 2018 Model Year, modified the Attention statement and added IAPT sensor information.</p> <p>February 2, 2018 - Removed thaw CAC information and added connector pinout reference.</p>

