



Service Bulletin

File in Section: -

Bulletin No.: 16-NA-370

Date: February, 2018

TECHNICAL

Subject: Sunroof Rattle, Creak, Tick and/or Double Click Noise During Operation

Brand:	Model:	Model Year:		VIN:		Engine:	Transmission:
		from	to	from	to		
Cadillac	CT6	2016	2017			All	All

Involved Region or Country	North America, Japan, Korea, Russian Federation, Europe, China, Middle East, Israel
Additional Options (RPO)	Equipped with Sunroof (RPO C3U)
Condition	<p>Some customers may comment on hearing any of the following noises during vehicle operation:</p> <ul style="list-style-type: none"> • Rattle • Creak • Tick • Double Click (usually heard when closing the sunroof)
Cause	<p>The cause of the condition may be attributed to part to part contact, such as any of the following:</p> <ul style="list-style-type: none"> • Metal to aluminum contact of the rear glass trough to the guide rail. • Metal to metal contact of the mechanism tab to the mechanism curve on the window slider. • Metal to aluminum contact at outboard left or right sunroof housing rivet locations. • The sunroof window inner middle seals may be an early first design, or a new second design seal may be mis-positioned/rolled. • Excessive material on the sunroof mechanism rubber isolator may be allowing double contact when the sunroof window travels.

Correction

A combination of different repairs, up to total of four, could be necessary depending on specific breakpoints of part changes and inspection of proper location of the sunroof window inner middle seals. Verify the condition(s) and follow the steps of the Service Procedure below to complete the appropriate repair(s).

Service Procedure

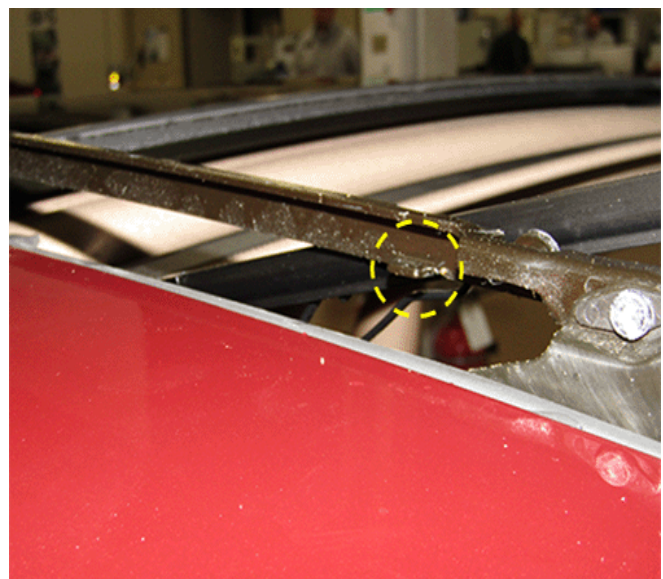

4622186

Note: The right side tab is shown circled in the graphic above. The front sunroof window was removed for illustration purposes only.

1. Open the front sunroof window enough to gain access to the tab which hangs down from the mechanism bracket, on each side of the sunroof. They are located approximately 30.5 mm (1.2 in) rearward of the front window screw.

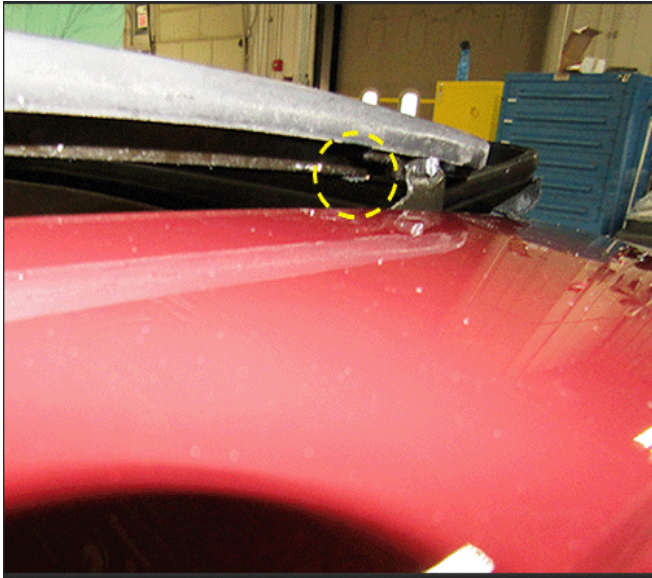

4622189

2. Apply GM - ACDelco Super Lube®* P/N 12371287 (in Canada, use P/N 10953437), or equivalent, to the top and bottom horizontal surfaces of the tabs on BOTH the left and right sides.
 - **For vehicles built prior to July 1, 2016,** continue to step #3.
 - **For vehicles built July 1, 2016 or after,** move ahead to step #7.

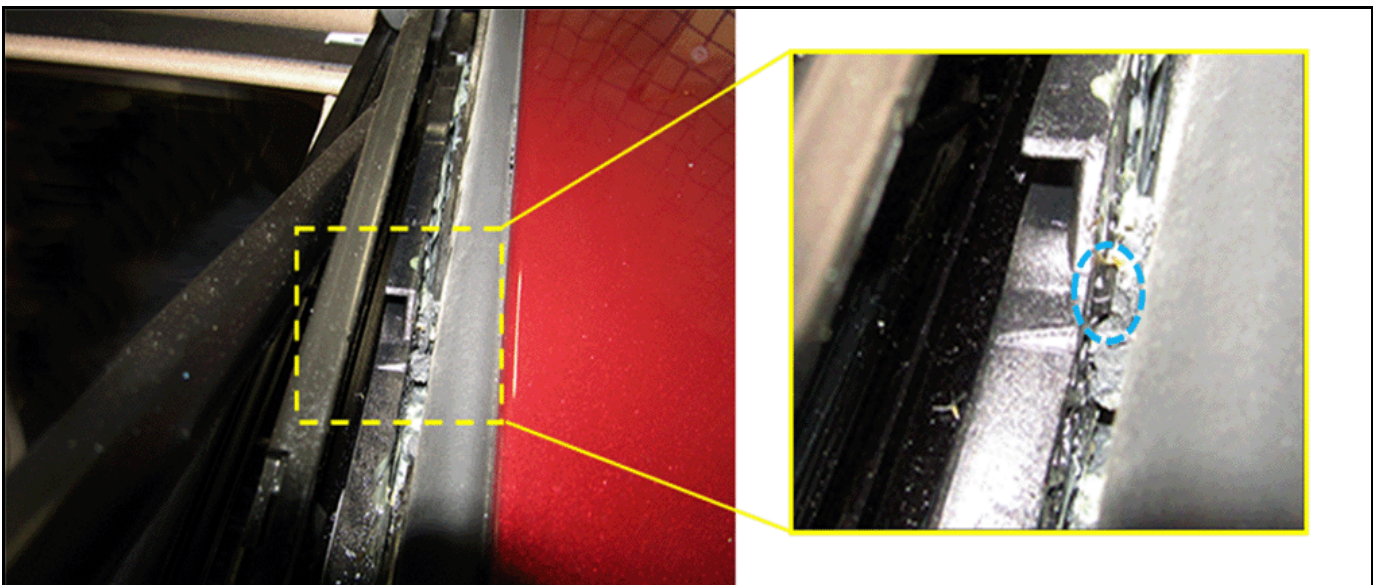

4622191

3. Locate the small “tail” extrusion on the rubber isolator on one side of the sunroof.

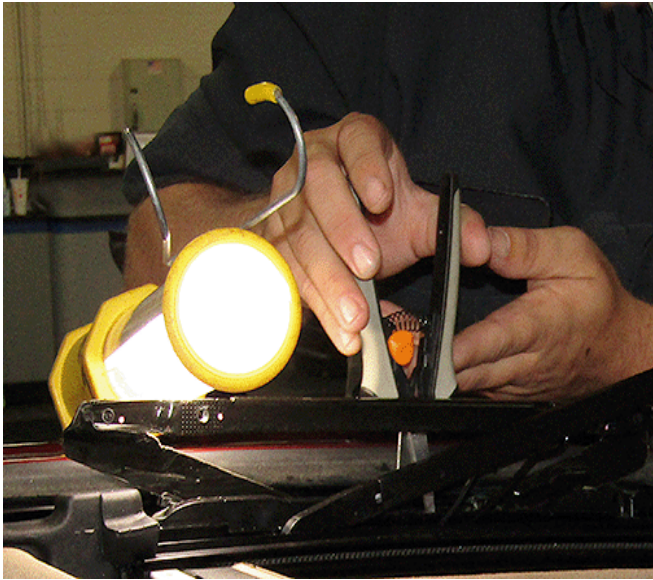

4622194

4. Using sharp nosed cutter/shears, or suitable tool, trim off the "tail" as flush to the surface as possible. The trimmed piece should stick to the shears for extraction.

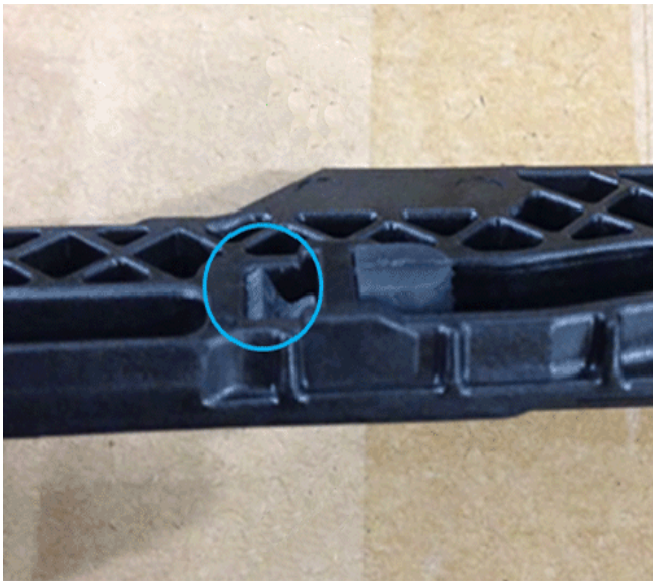

4624462

5. Examine isolator to see if further trimming is required, and if so, go straight down and trim further. A flush trimmed isolator is shown circled in the graphic above.
6. Repeat steps 3-5 on the opposite side.

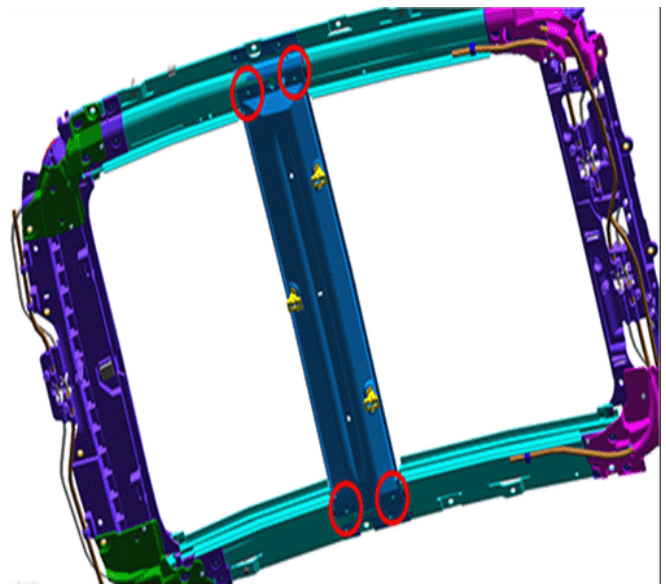

4622199

7. For earlier built vehicles, it will be necessary to remove four outboard rivets, two each side, from the center frame of the sun housing.
 - For vehicles built June 17, 2016 and prior, continue to step #7.1.
 - For vehicles built after June 17, 2016, move ahead to step #15.

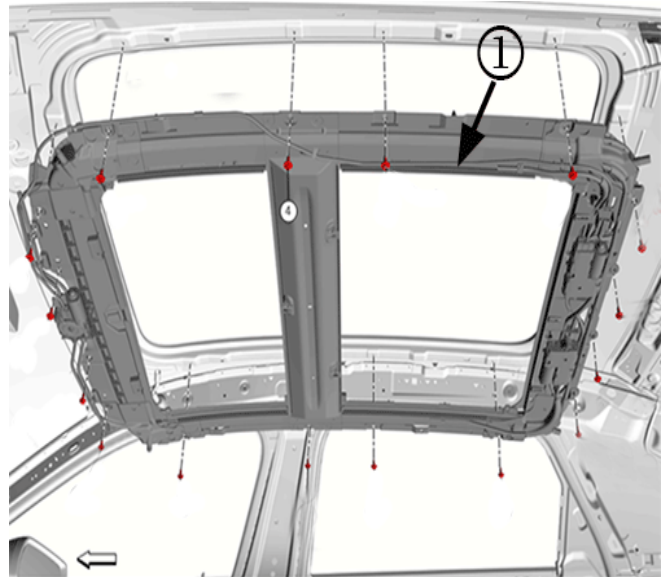

4622202

- 7.1. Remove the sunroof housing assembly (1). Refer to *Sunroof Housing Replacement (With C3U)* in SI.
- 7.2. Place housing on a protected, suitable table/bench with the underside facing up.

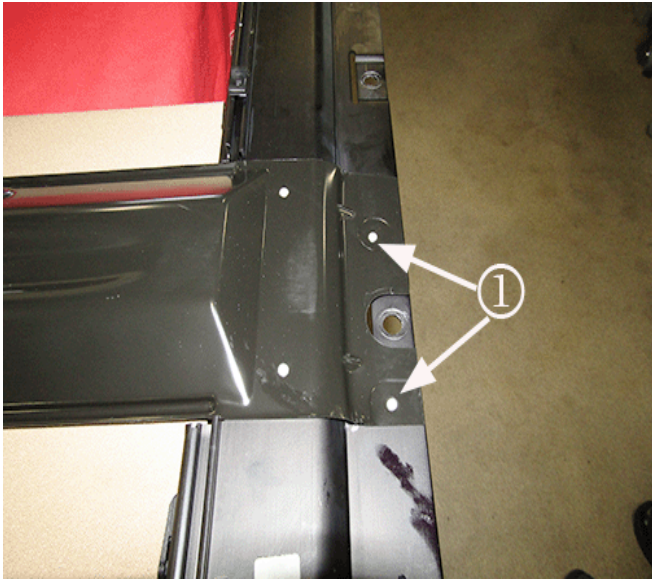

4622207

7.3. Locate the two center, outboard rivets (1) on one side of the housing.

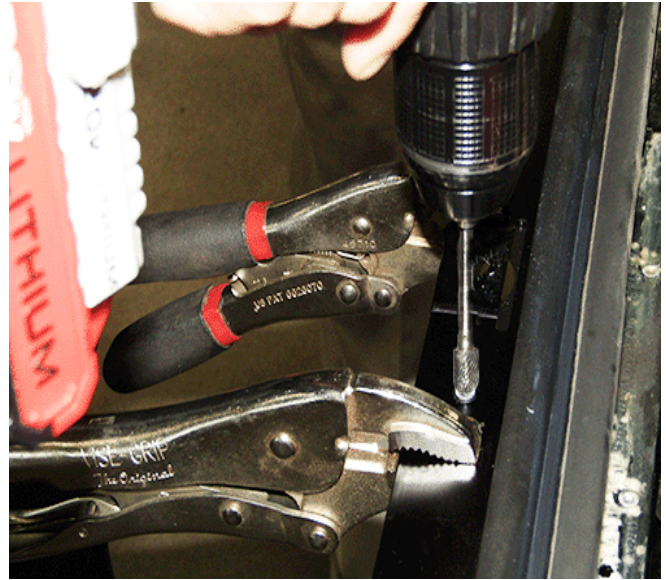

4622214

7.5. Using a carbide die grinder bit, or equivalent tool, carefully grind off the head of the rivet at both locations.

7.6. Punch out the rivets from the two locations.

7.7. Repeat steps 7.3-7.6 on the opposite side.



4622210

7.4. Install vise-grips or a suitable tool, to the housing to hold the metal frame layers in position, while grinding the rivets.

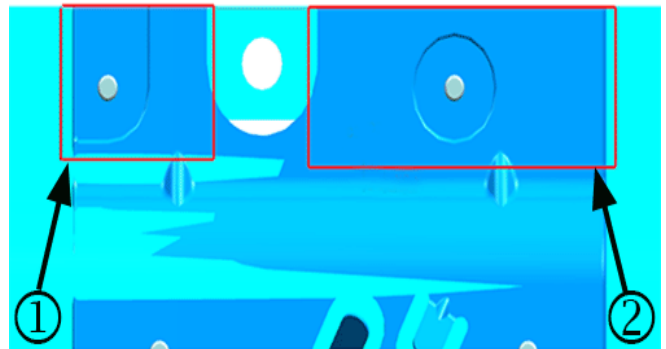

4622218

8. Cut four pieces of *Kent Automotive BRS Tape P/N KT13486, or equivalent flocking tape; two pieces approximately 30 x 45 mm (1.2 x 1.8 in) (1) and two pieces approximately 30 mm x 90 mm (1.2 x 3.6 in) (2).

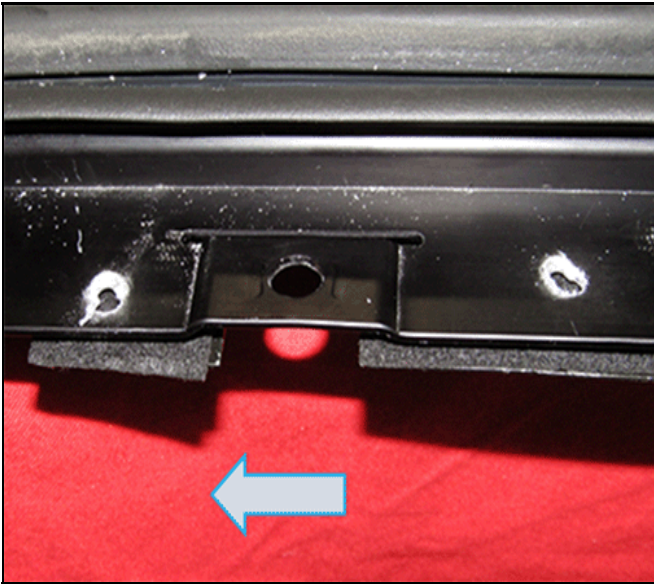

4622222

9. As shown in the graphic above, apply the four pieces of flocking tape between the metal flanges of the sunroof frame at the four removed rivet locations. The smaller pieces forward, the larger pieces rearward.
10. Flip over the sunroof housing so you have access to the top side.

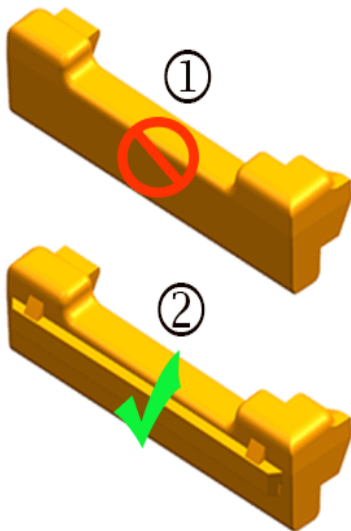

4622225

Note: To improve performance, a more robust second design of the sunroof inner middle seal has been implemented. The first graphic above shows the difference between the first (1) and second (2) design level.

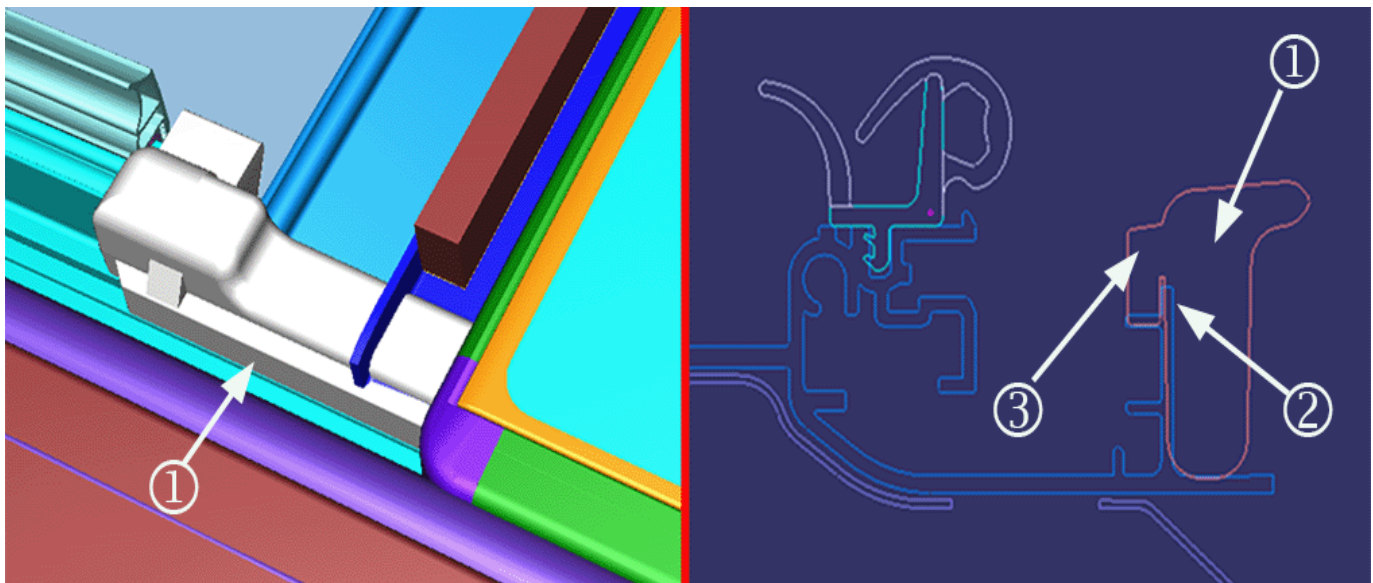

4622229

Note: The second graphic shows an illustration and cross-section of the correct positioning of the second design seal (1). The added portion of the seal (3) is intended to cap-over the guide flange (2) and isolate the drain channel from contact with the guide flange.

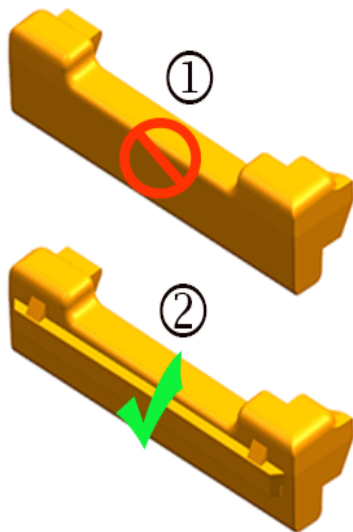

4622225



4622231

11. Inspect the sunroof window inner middle seals on both sides of the sunroof. We first want to ensure the vehicle has the new second design seals, and if so, want to make sure the seals are properly positioned.

- For vehicles equipped with first design seals (1), continue to step #12.
- For vehicles equipped with second design seals (2):

⇒ Inspect the seals for evidence of them being mis-positioned, or rolled out of position on either or both sides. If this condition exists and the guide flange is exposed, there will likely be corrosion evident (shown circled above), due to the metal to metal contact of drain channel to the guide. If exposure of the guide flange or corrosion is evident, continue to step #12.

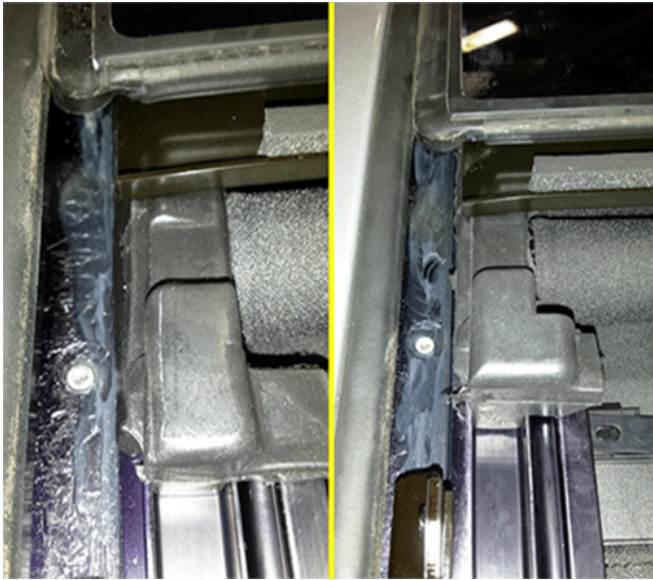

4622234

⇒ The graphic above shows examples of proper seal installation. Some slight roll of the seal is acceptable as long as the drain channel is completely isolated from the guide flange. If they are properly positioned on both sides, move ahead to step #13.

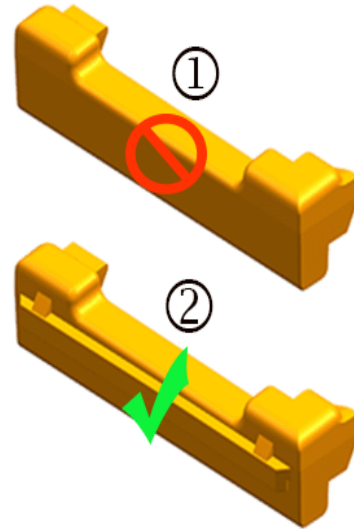

4622225

Note: To improve performance, a more robust second design of the sunroof inner middle seal has been implemented. The first graphic above shows the difference between the first (1) and second (2) design level.

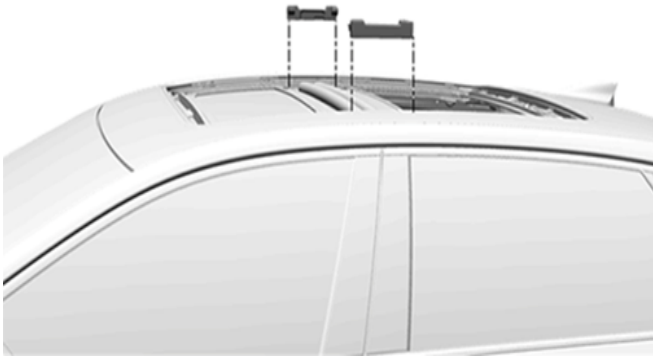

4622238

12. For vehicles with first design seals, replace both sides; for second design seals, replace only the affected side. Refer to *Sunroof Window Seal Replacement (Inner Middle Seal With C3U)* in SI.
13. Reinstall the sunroof housing assembly. Refer to *Sunroof Housing Replacement (With C3U)* in SI.
14. Move ahead to step #17.

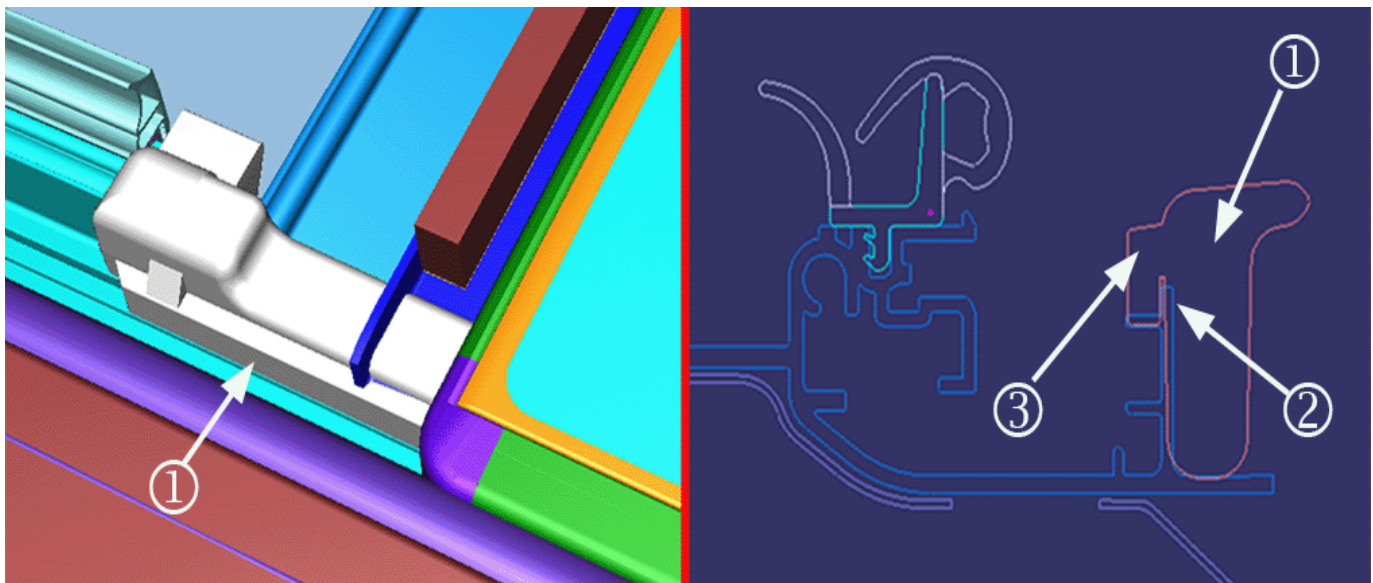

4622229

Note: The second graphic shows an illustration and cross-section of the correct positioning of the second design seal (1). The added portion of the seal (3) is intended to cap-over the guide flange (2) and isolate the drain channel from contact with the guide flange.

seals (2):

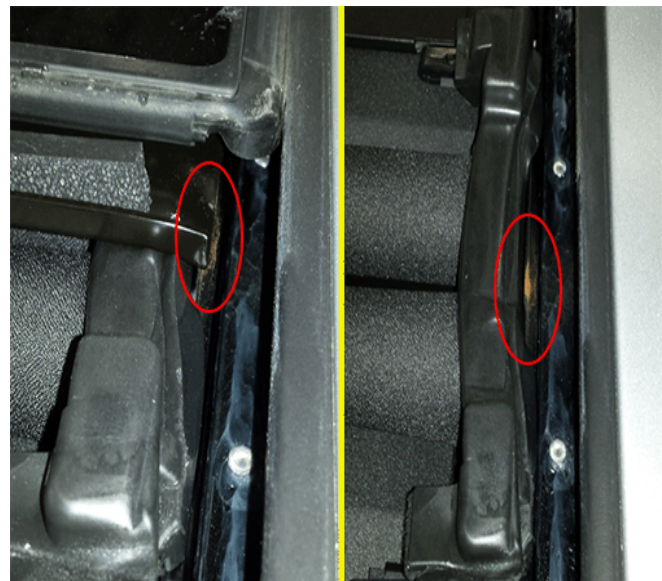

4622231

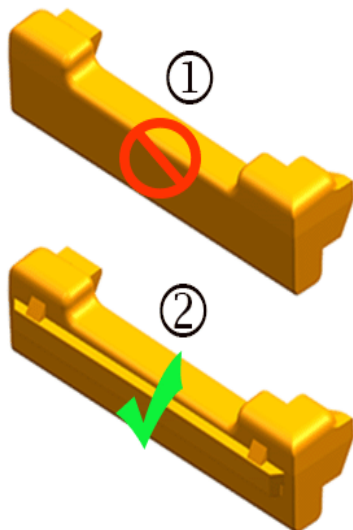

4622225

15. Open the front sunroof window and inspect the sunroof window inner middle seals on both sides of the sunroof. We first want to ensure the vehicle has the new second design seals, and if so, want to make sure the seals are properly positioned.

- For vehicles equipped with first design seals (1), continue to step #16.
- For vehicles equipped with second design

⇒ Inspect the seals for evidence of them being mis-positioned, or rolled out of position on either or both sides. If this condition exists and the guide flange is exposed, there will likely be corrosion evident (shown circled above), due to the metal to metal contact of drain channel to the guide. If exposure of the guide flange or corrosion is evident, continue to step #16.

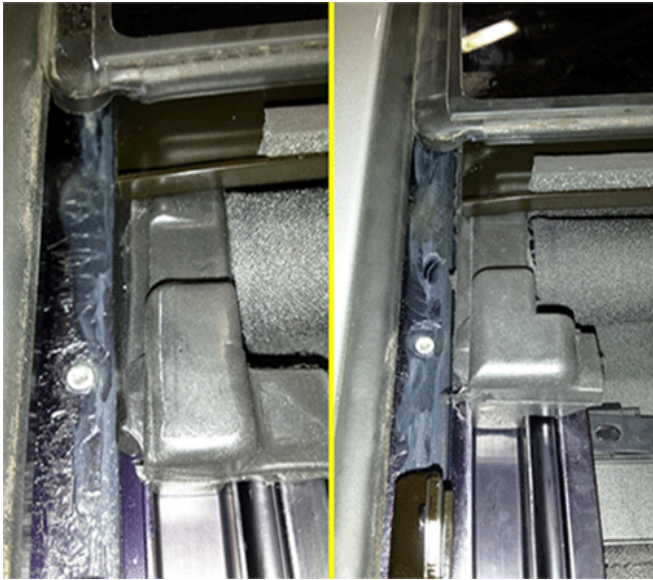

4622234

⇒ The graphic above shows examples of proper seal installation. Some slight roll of the seal is acceptable as long as the drain channel is completely isolated from the guide flange. If they are properly positioned on both sides, move ahead to step #17.

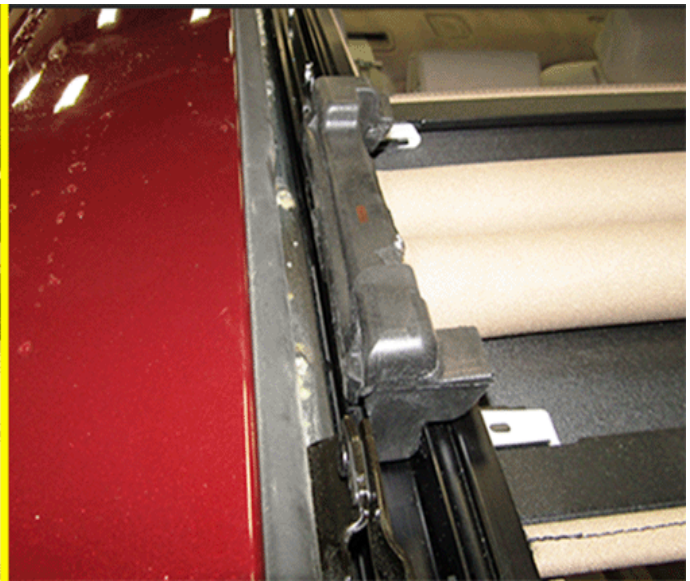

4622244

16. For vehicles with first design seals, replace both sides; for second design seals, replace only the affected side. Refer to *Sunroof Window Seal Replacement (Inner Middle Seal With C3U)* in SI.
17. Verify noise conditions have been eliminated and proper operation of sunroof.

*We believe this source and their products to be reliable. There may be additional manufacturers of such products/materials. General Motors does not endorse, indicate any preference for, or assume any responsibility for the products or material from this firm or for any such items that may be available from other sources.

Parts Information

Order BRS Tape from Kent Automotive at 1-888-YES-KENT, or online at www.kent-automotive.com.

Description	Part Number	Qty
SEAL-SUN RF WDO	84114679	1, if necessary
SEAL-SUN RF WDO	84114680	1, if necessary
Kent Automotive BRS Tape	KT13486	4 pieces, if necessary

Warranty Information

For vehicles repaired under the Bumper-to-Bumper coverage (Canada Base Warranty coverage), use the following labor operation. Reference the Applicable Warranties section of Investigate Vehicle History (IVH) for coverage information.

Labor Operation	Description	Labor Time
6080198*	Lubricate Sunroof Mechanism Tabs	0.2 hr
Add	Trim Isolator Tails	0.1 hr
Add	Install Second Design Seals, Only	1.4 hrs
Add	Remove Outboard Sunroof Housing Rivets (Inc. Install Seal(s))	7.0 hrs
*This is a unique Labor Operation for Bulletin use only.		

Version	2
Modified	February 16, 2018 – Updated the coverage statement and some Labor Times under Warranty Information.

