

SERVICE BULLETIN

Reference number:	SB-05-1006	Issued: 19 April, 2018
Subject:	DB11 V8 Driveshaft Click	
Model(s):	DB11 V8	
VIN Range:	All Vehicles	
Applicable to:	All Dealers	
Distribute to:	After Sales Manager Service Manager Sales Manager	Warranty Staff Technician(s) Parts Staff

Reason for this Service Bulletin

On some vehicles we have found that a loud click can be heard when:

- The driver changes from drive to reverse, or changes from reverse to drive, and
- The driver starts to accelerate.

This problem is caused by movement between the driveshaft and hub-bearing mating surfaces. If a Customer makes a complaint that they can hear a loud click of this type, do the Workshop Procedure that follows to correct this problem.

Workshop Procedure

WARNINGS: DO NOT USE COMPRESSED AIR TO REMOVE BRAKE PAD DUST. THE DUST CAN BE DANGEROUS. ALWAYS USE A VACUUM BRUSH OR THE RECOMMENDED BRAKE CLEANER TO REMOVE BRAKE PAD DUST.

ALWAYS USE THE CORRECT BRAKE PADS THAT ARE SUPPLIED BY ASTON MARTIN. IF YOU DO NOT USE THE CORRECT BRAKE PADS, IT IS POSSIBLE THAT THE BRAKES MAY NOT OPERATE CORRECTLY AND CAN FAIL.

BRAKE PAD DUST CAN BE HARMFUL IF YOU BREATHE IT IN OR GET IT IN YOUR EYES. ALWAYS USE FACE AND EYE PROTECTION WHEN YOU CLEAN THE BRAKE COMPONENTS.

DO NOT SOAK OR PUT THE BRAKE PADS FULLY INTO SOLVENT CLEANER. IF YOU DO, IT IS POSSIBLE THAT THEY MAY NOT OPERATE CORRECTLY AND CAN FAIL.

CAUTIONS: DO NOT USE LEVERS OR SCREWDRIVERS TO RETRACT THE PISTONS INTO THE BRAKE CALIPER. IF YOU DO, YOU CAN SLIP AND CAUSE DAMAGE TO THE DISC.

DO NOT USE LEVERS IN THE VENT CANALS OF THE DISC. IT MAY DAMAGE THE DISC.

DO NOT USE WATER, CLEANING LIQUIDS OR TRICHLOROETHYLENE TO CLEAN THE DISCS OR THE PADS. IF YOU DO, IT MAY DAMAGE THEM. USE ONLY THE RECOMMENDED SOLVENTS TO CLEAN THE DISCS AND PADS.

1. Remove the cap from the brake-fluid reservoir.

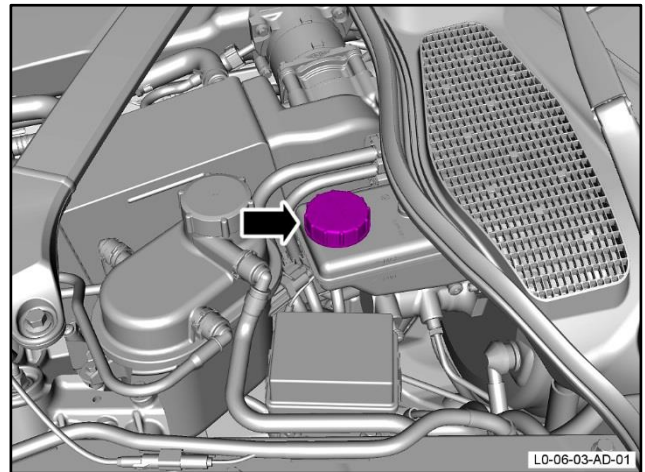

Figure 1

2. Remove the rear wheel (refer to Workshop Manual procedure 04.04.EC).
3. Disconnect the pad wear lead from the brake pad, and release it from the brake caliper.

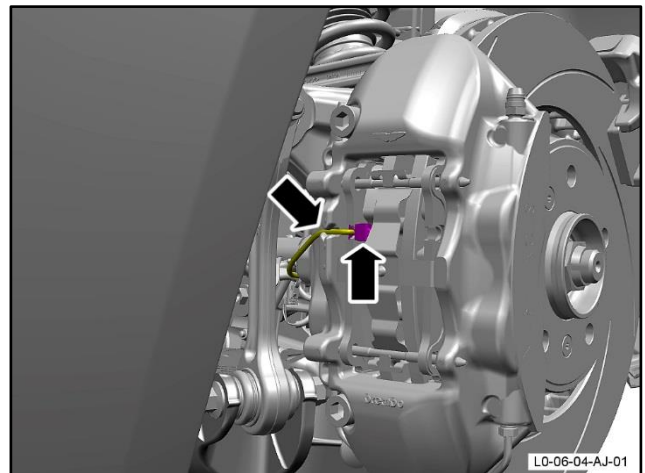

Figure 2

4. Remove the two pins that attach the brake pads to the brake caliper.

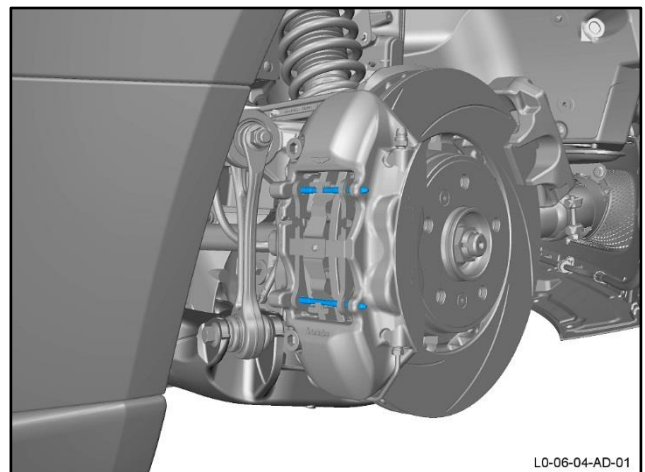

Figure 3

5. Remove the anti-rattle spring from the brake caliper.

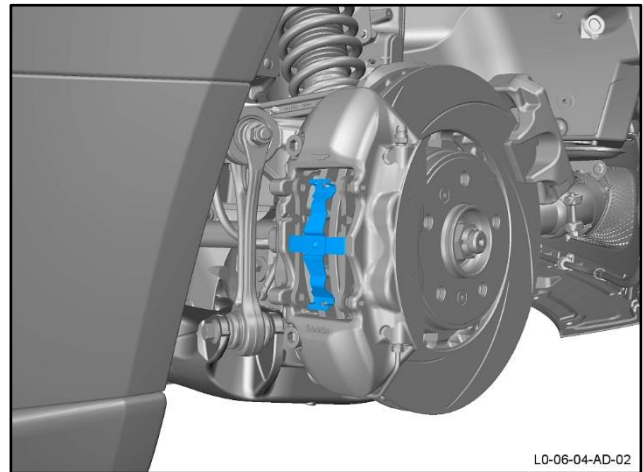

Figure 4

6. Remove the brake pads and anti-squeal shims from the brake caliper.

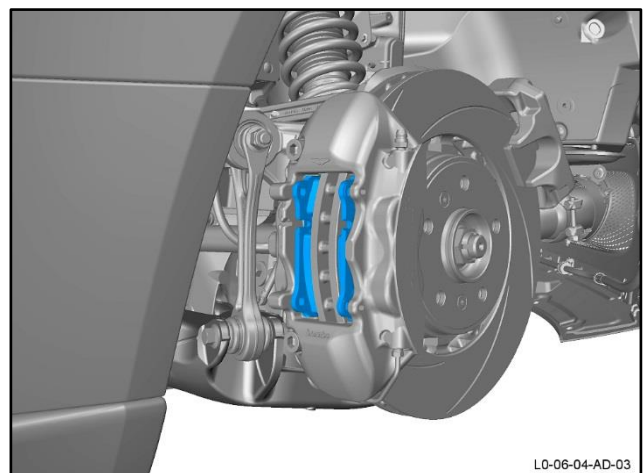

Figure 5

7. Remove and discard the two bolts that attach the brake caliper to the knuckle.

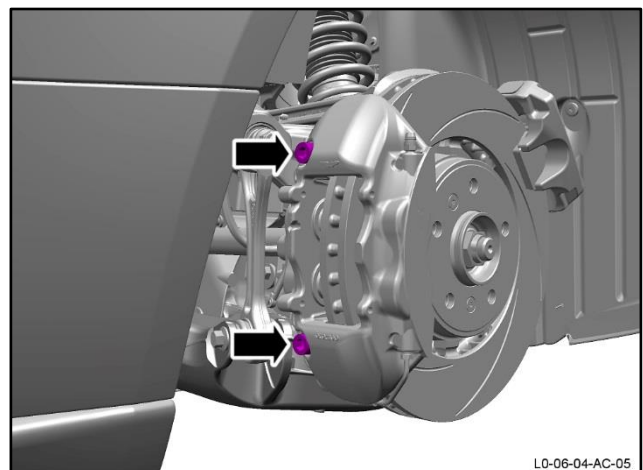
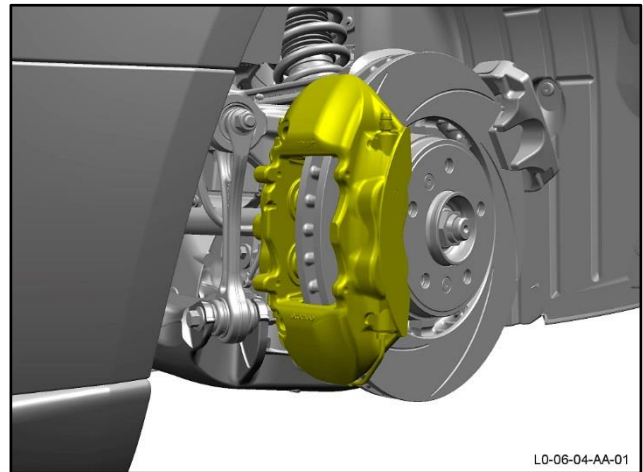

Figure 6

CAUTION: MAKE SURE THAT THE BRAKE CALIPER DOES NOT HANG ON THE BRAKE HOSE. THIS WILL HELP TO PREVENT DAMAGE TO THE BRAKE HOSE.

Note: Use an applicable cable tie to hold the brake caliper.

8. Release the brake caliper from the knuckle.

**Figure 7**

9. Put the hub holding tool into position.

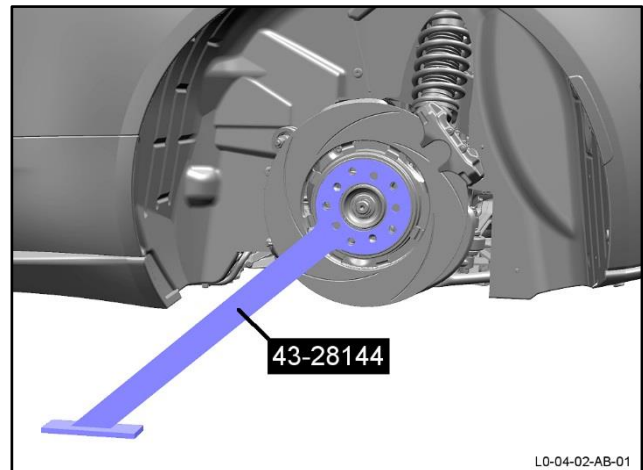
**Figure 8**

10. Install and tighten the three bolts that attach the hub holding tool to the hub.

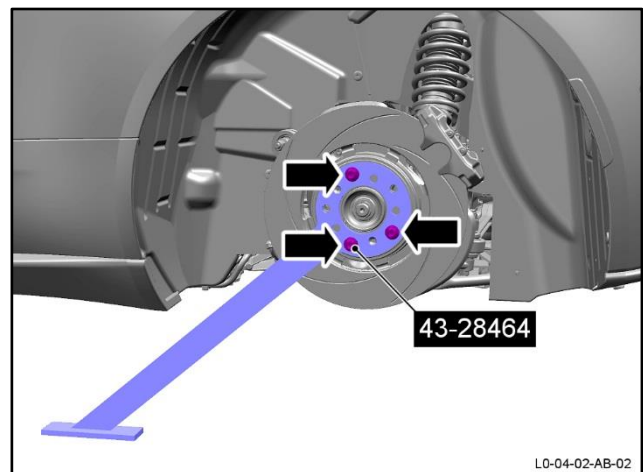
**Figure 9**

11. Remove the driveshaft nut and washer.

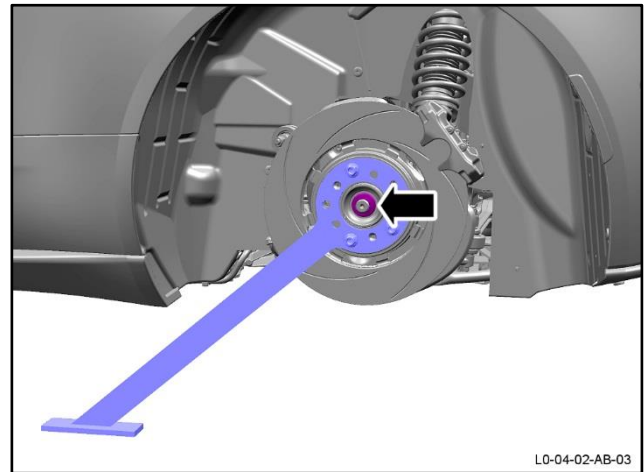

Figure 10

12. Release the driveshaft from the hub and bearing assembly.

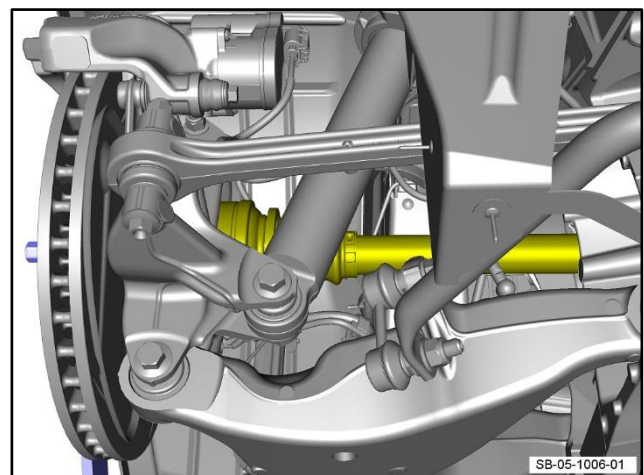

Figure 11

13. Apply the Anti-Fret paste to the surface of the driveshaft as shown (refer to Figure 12).

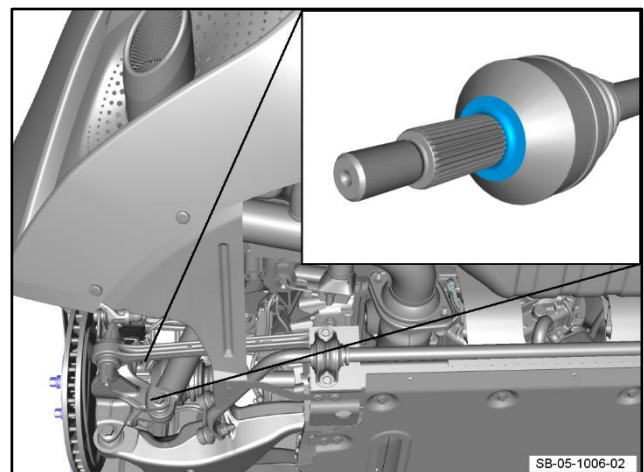

Figure 12

14. Install the driveshaft to the hub and bearing assembly.

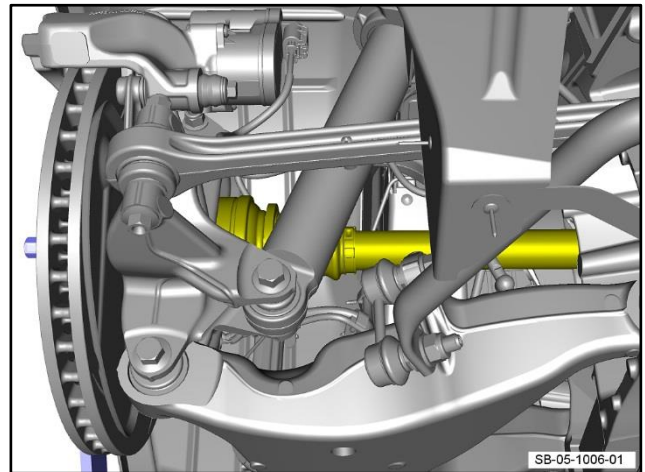

Figure 13

15. Remove the three bolts that attach the hub holding tool to the hub.

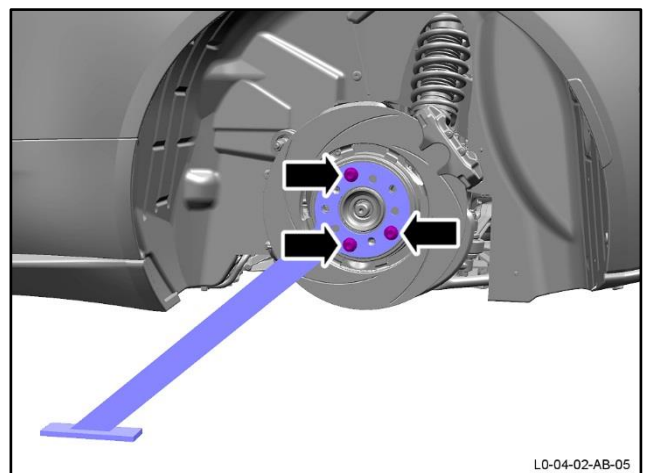

Figure 14

16. Remove the hub holding tool.

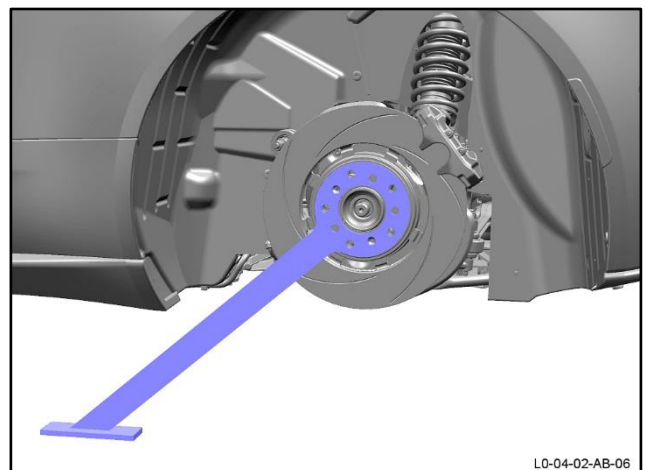

Figure 15

17. Put the hub holding tool into position.

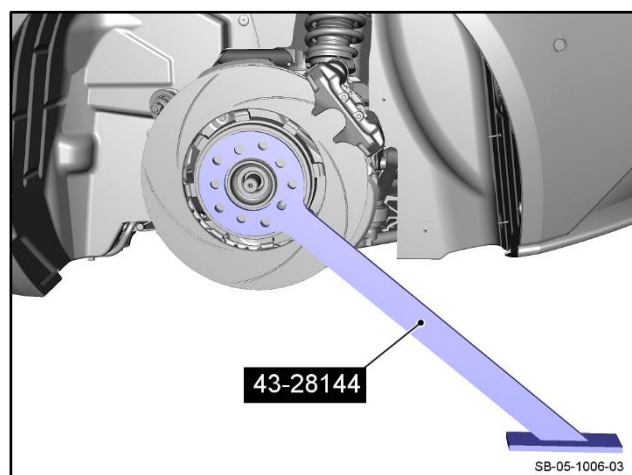

Figure 16

18. Install and tighten the three bolts that attach the hub holding tool to the hub.

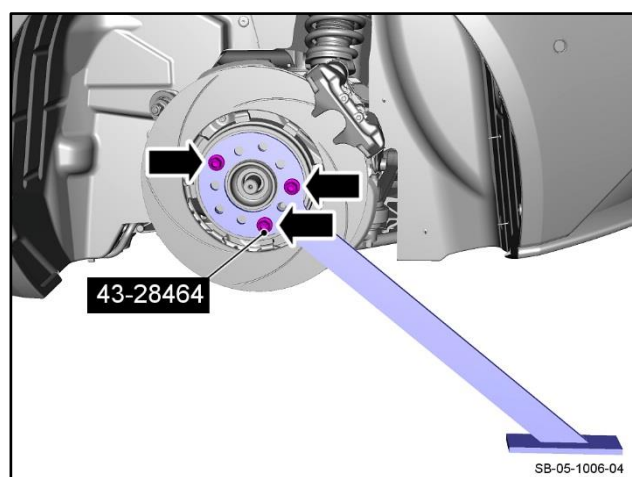

Figure 17

19. Install and torque the driveshaft nut and washer to 300 Nm.

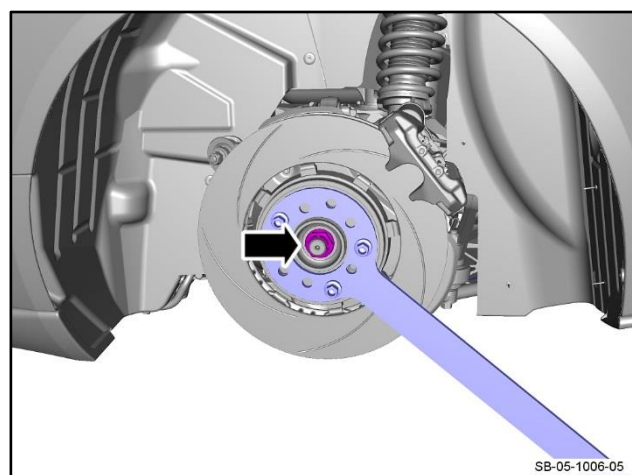

Figure 18

20. Remove the three bolts that attach the hub holding tool to the hub.

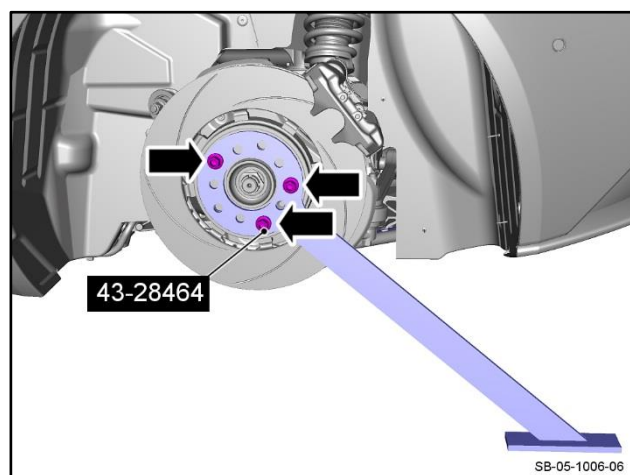

Figure 19

21. Remove the hub holding tool.

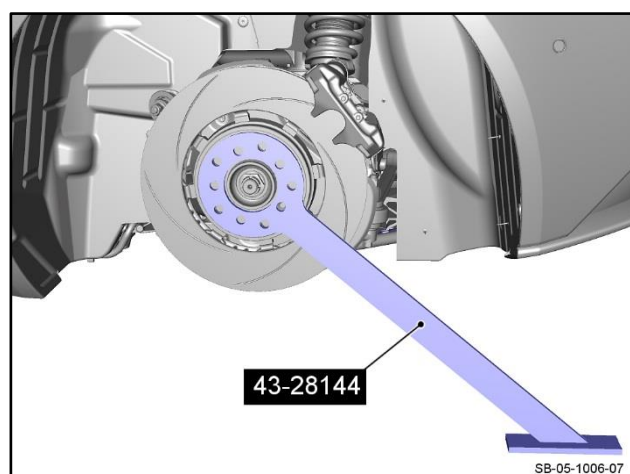

Figure 20

22. Use an approved solvent to clean the brake pads, pins and anti-squeal shims.
23. Install the brake caliper to the knuckle.

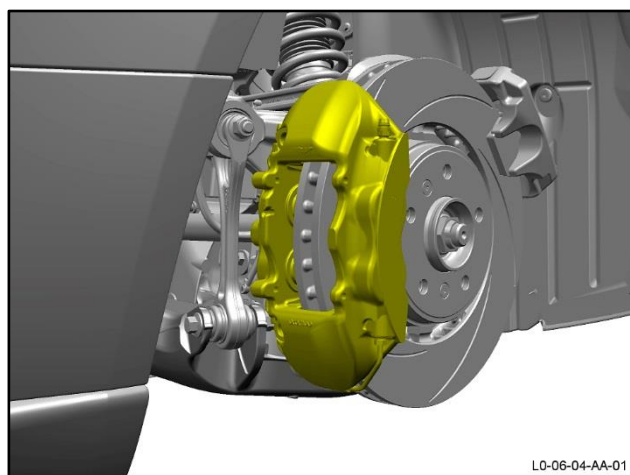

Figure 21

CAUTION: USE NEW BOLTS TO ATTACH THE BRAKE CALIPER TO THE KNUCKLE. IF YOU DO NOT USE NEW BOLTS FAILURE OF THE BRAKE SYSTEM CAN OCCUR.

24. Install and torque the two bolts that attach the brake caliper to the knuckle to **30 Nm**, then **tighten 80 degrees** more.

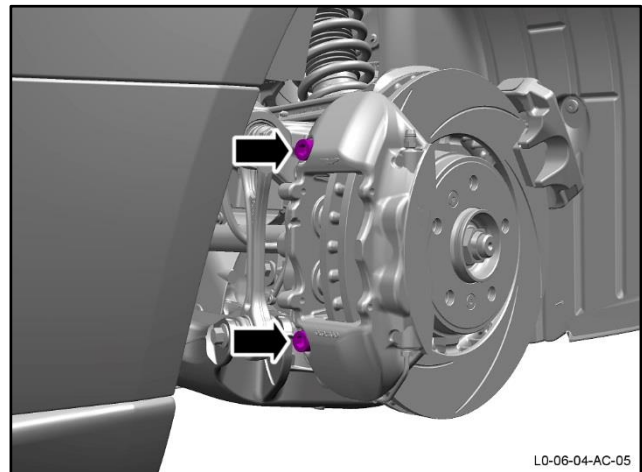

Figure 22

25. Use an approved solvent to clean the brake pads, pins and anti-rattle spring.

Note: *In the step that follows, examine the brake pads for wear or damage. Replace them if necessary.*

26. Install the brake pads to the brake caliper.

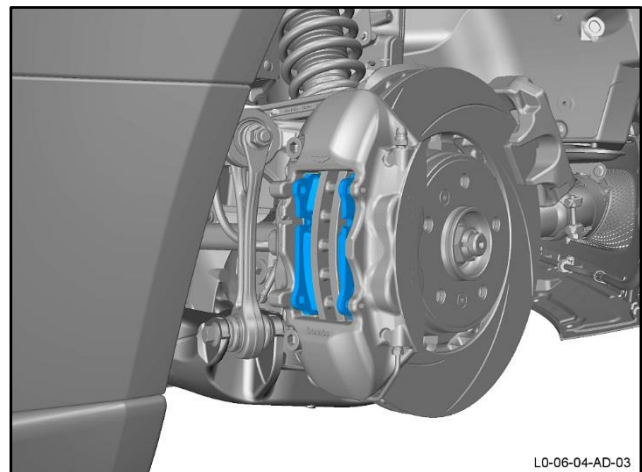

Figure 23

27. Install the anti-rattle spring to the brake caliper.

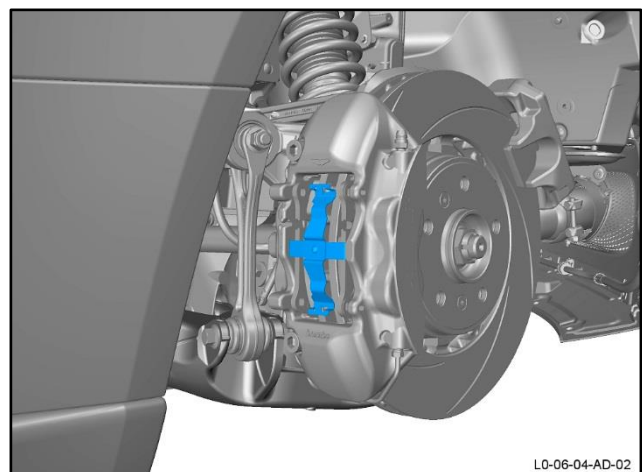

Figure 24

28. Install the two pins that attach the brake pads to the brake caliper.

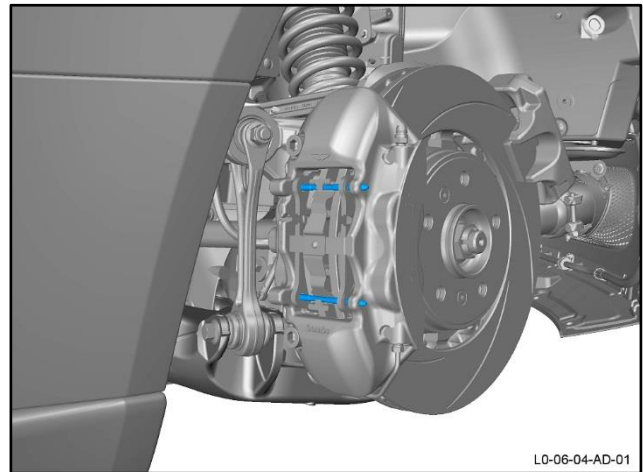

Figure 25

29. Connect the pad wear lead to the brake pad, and install it to the brake caliper.

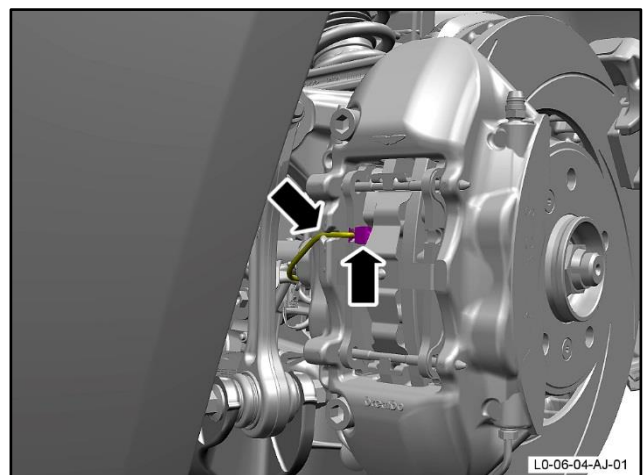

Figure 26

30. Install the rear wheel (refer to Workshop Manual procedure 04.04.EC).

Note: Steps 2 thru 30 show the Workshop Procedure to lubricate the left side driveshaft. The procedure to lubricate the right side driveshaft is the same.

31. To lubricate the right side driveshaft, do steps 2 thru 30 again.

32. Install the cap from the brake-fluid reservoir.

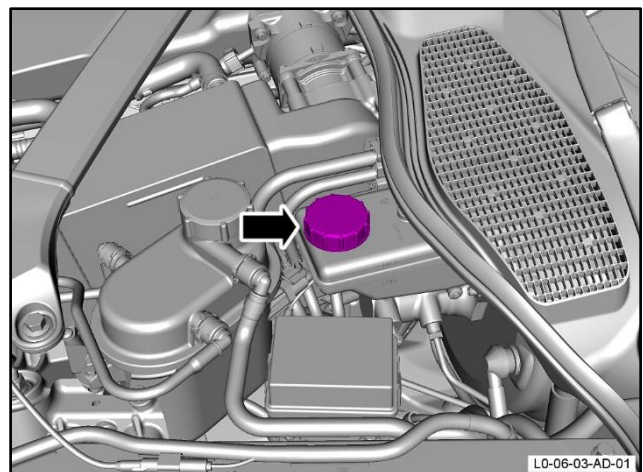

Figure 27

Part Data

Description	Part Number	Quantity
Bolt, M12 x 80	8D33-2C564-AA	4
Anti-Fret Paste (Due in stock before the end of April 2018)	JY53-M4G49-AA	1

Warranty Data**Procedure and Labour Time**

Description	Labour Time	ROT Code
SB051006 – DB11 V8 Driveshaft Click	0.8 hours	05.01.AF

Failure Mode Description

Select the failure modes that follow when you make a claim through the Warranty system:

Subsystem	Location	Component	Mode of Failure
CHASSIS	- SUSPENSION - REAR - LHS	- REAR - WHEEL HUB - BEARING	- NOISY OPERATION
CHASSIS	- SUSPENSION - REAR - LHS	- REAR - WHEEL HUB	- POOR PERFORMANCE - VIBRATION / RESONANCE
CHASSIS	- SUSPENSION - REAR - RHS	- REAR - WHEEL HUB - BEARING	- NOISY OPERATION
CHASSIS	- SUSPENSION - REAR - RHS	- REAR - WHEEL HUB	- POOR PERFORMANCE - VIBRATION / RESONANCE
POWERTRAIN	- DRIVETRAIN	- FINAL DRIVE - HALF SHAFT - LHS	- POOR PERFORMANCE - VIBRATION / RESONANCE
POWERTRAIN	- DRIVETRAIN	- FINAL DRIVE - HALF SHAFT - RHS	- POOR PERFORMANCE - VIBRATION / RESONANCE
POWERTRAIN	- DRIVETRAIN	- FINAL DRIVE - HALF SHAFT - SPLINE - LHS	- NOISY OPERATION - CLUNK / KNOCK
POWERTRAIN	- DRIVETRAIN	- FINAL DRIVE - HALF SHAFT - SPLINE - RHS	- NOISY OPERATION - CLUNK / KNOCK
POWERTRAIN	- DRIVETRAIN	- FINAL DRIVE - HALF SHAFT - UNIVERSAL JOINT - LHS	- NOISY OPERATION - CLUNK / KNOCK
POWERTRAIN	- DRIVETRAIN	- FINAL DRIVE - HALF SHAFT - UNIVERSAL JOINT - RHS	- NOISY OPERATION - CLUNK / KNOCK

If you have any questions related to this Service Bulletin, please contact: Aston Martin Technical Services
on: +44 (0) 1926 644720, email: askamtech@astonmartin.com,
Or contact your After Sales Manager.

The English version of this Service Bulletin is written in
Simplified Technical English to ASD-STE100™.