

# Technical Service Bulletin

Mazda North American Operations  
Irvine, CA 92618-2922



<b>Subject:</b>  <b>AIR CONDITIONING MUSTY / MILDEW ODOR</b>	<b>Bulletin No.:</b> 07-002/18
	<b>Last Issued:</b> 04/16/2018

## BULLETIN NOTES

This bulletin supersedes the previously issued bulletin(s) listed below. The changes are noted below in Red beside the change bars.

Previously Issued TSBs	Dates(s) Issued	Previous Issued TSBs	Dates(s) Issued
07-002/13	10/28/13	07-001/07	06/08/07
07-002/09	06/24/09	07-001/03	05/02/03
07-006/08	10/15/08		

## APPLICABLE MODEL(S)/VINS

1998 MPV	1999-2005 Miata	2007- <del>2018</del> CX-9
2000-2006 MPV	1998-2002 Millenia	2004- <del>2018</del> Mazda3
1998-2002 626	2006- <del>2018</del> MX-5	2006- <del>2015</del> Mazda5
1998-2003 Protege	2013- <del>2018</del> CX-5	2003- <del>2018</del> Mazda6
2002-2003 Protege5	2007-2012 CX-7	2011-2014 Mazda2

## DESCRIPTION

A musty/mildew type odor may come from the vents when the air conditioning (A/C) system is operating. It is most noticeable when the A/C is first turned ON. This odor is the result of mold growth in the A/C evaporator/cooling unit which is caused by condensation, dust, and pollen within the cooling unit. This condition is usually worse during high humidity conditions. "Mazda Air Cooling Coil Coating" is available to encapsulate the mold to reduce odors. If the product is properly applied, it can effectively reduce the musty/mildew odor for up to three years.

**NOTE:** See parts information for Mazda Air Cooling Coil Coating and Kit part numbers.

**CONSUMER NOTICE:** The information and instructions in this bulletin are intended for use by skilled technicians. Mazda technicians utilize the proper tools/equipment and take training to correctly and safely maintain Mazda vehicles. These instructions should not be performed by "do-it-yourselfers." Customers should not assume this bulletin applies to their vehicle or that their vehicle will develop the described concern. To determine if the information applies, customers should contact their nearest authorized Mazda dealership. Mazda North American Operations reserves the right to alter the specifications and contents of this bulletin without obligation or advance notice. All rights reserved. No part of this bulletin may be reproduced in any form or by any means, electronic or mechanical---including photocopying and recording and the use of any kind of information storage and retrieval system ---without permission in writing.

This treatment provides a durable coating that will aid to prevent biological reactions that lead to odor concerns. It is applied to the evaporator in a misted form that is introduced by way of the cabin air filter, the re-circulate door, the blower motor resistor access, or the blower motor air intake. Proper application requires the evaporator surface to be:

- Relatively clean and free of leaves, dust build-up and debris.
- Thoroughly dried, and the product cured onto it after application.

**NOTE:**

- Keep the cooling unit dry by leaving the blower fan ON (at least on low), even if the A/C is not being used.
- In low humidity (dry) conditions, keep the ventilation system in the “FRESH” mode all the time, or as much as possible.
- In high humidity conditions, or if the air has a lot of dust or pollen, keep the system in the “RECIRCULATION” mode.
- A few minutes before reaching a destination, turn the A/C OFF, but leave the blower fan ON. This stops the accumulation of condensation on the evaporator/cooling unit, and it helps dry the inside of the cooling unit.
- A/C odor is not unique to Mazda vehicles as it will occur in other makes and models.
- To minimize A/C odor, suggest the following to the customers:

Customers having this concern should have their vehicle repaired using the following procedure.

**Note:** This repair is not covered by warranty.

**CONSUMER NOTICE:** The information and instructions in this bulletin are intended for use by skilled technicians. Mazda technicians utilize the proper tools/equipment and take training to correctly and safely maintain Mazda vehicles. These instructions should not be performed by “do-it-yourselfers.” Customers should not assume this bulletin applies to their vehicle or that their vehicle will develop the described concern. To determine if the information applies, customers should contact their nearest authorized Mazda dealership. Mazda North American Operations reserves the right to alter the specifications and contents of this bulletin without obligation or advance notice. All rights reserved. No part of this bulletin may be reproduced in any form or by any means, electronic or mechanical---including photocopying and recording and the use of any kind of information storage and retrieval system ---without permission in writing.

## REPAIR PROCEDURE

1. Verify customer concern.
2. Verify the evaporator drain has no blockage.
3. Apply “Mazda Air Cooling Coil Coating” according to the attached instructions. Refer to the table below for the applicable repair instructions.

Repair Procedure	PDF Pages	Repair Procedure	PDF Pages	Repair Procedure	PDF Pages
2016-2018 MX-5	4-6	2011-2014 Mazda2	21-22	1998-2003 Protege/Protege5	38-39
2016-2018 CX-9 Front A/C	7-9	2007-2012 CX-7	23-24	2000-2003 MPV Front A/C	40-41
2016-2018 CX-9 Rear A/C	10	2003-2013 Mazda6	25-27	2000-2003 MPV Rear A/C	42
2013-2018 CX-5	11-15	2004-2013 Mazda3	28-32	1998 MPV Front A/C	43-44
2014-2018 Mazda3	11-15	2006-2015 Mazda5	28-32	1998 MPV Rear A/C	45
2014-2018 Mazda6	11-15	2006-2015 MX-5	33-35	2001-2002 Millenia	46-48
2007-2015 CX-9 Front A/C	16-18	1998-2002 626	36-37	1998-2000 Millenia	49-50
2007-2015 CX-9 Rear A/C	19-20			1999-2005 Miata	51-52

### NOTE:

- Follow the attached instructions completely to ensure an effective repair. If insufficient care is taken on the drying sequence of product, the coating will not last, and the concern will reoccur.
- If the odor is still present after treatment, it may be necessary to remove and clean the evaporator, the evaporator foam, and the inside of the cooling unit housing with a mild dish soap and water solution. To avoid damage to components, do not clean with bleach. See Workshop Manual section 07 for removal instructions.

### WARNING:

- When using this product, avoid skin and eye contact. Wear safety glasses and gloves, and avoid breathing vapors.
- Read all the safety and first aid instructions on the back of the Mazda bottle.

4. Verify repair.

**CONSUMER NOTICE:** The information and instructions in this bulletin are intended for use by skilled technicians. Mazda technicians utilize the proper tools/equipment and take training to correctly and safely maintain Mazda vehicles. These instructions should not be performed by “do-it-yourselfers.” Customers should not assume this bulletin applies to their vehicle or that their vehicle will develop the described concern. To determine if the information applies, customers should contact their nearest authorized Mazda dealership. Mazda North American Operations reserves the right to alter the specifications and contents of this bulletin without obligation or advance notice. All rights reserved. No part of this bulletin may be reproduced in any form or by any means, electronic or mechanical---including photocopying and recording and the use of any kind of information storage and retrieval system ---without permission in writing.

**2016-2018 MX-5**

1. Dry the evaporators using the following procedure:

**WARNING:** Running the engine inside an enclosed area, such as a garage, is dangerous. Exhaust gas, which contains poisonous carbon monoxide, could easily enter the cabin. Loss of consciousness or even death could occur. Don't run the engine when inside an enclosed area.

a. Start the engine.

b. Set the HVAC controls as follows.

- RECIRCULATE (1)
- FULL HEAT (2)
- FAN HIGH (3)
- A/C OFF (4)
- AIRFLOW - FACE (5)

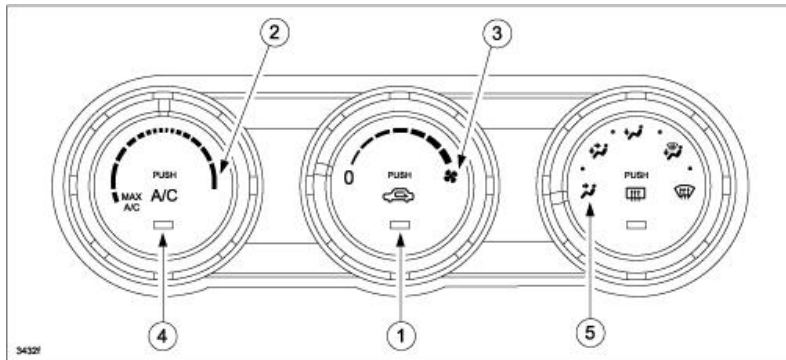
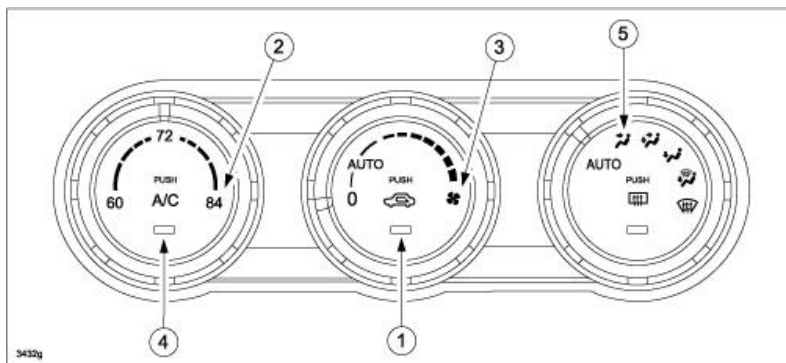
**MANUAL TYPE****FULLY AUTOMATIC TYPE**

c. Open one window approximately one half inch.

d. Let the engine run for 15 minutes.

**CONSUMER NOTICE:** The information and instructions in this bulletin are intended for use by skilled technicians. Mazda technicians utilize the proper tools/equipment and take training to correctly and safely maintain Mazda vehicles. These instructions should not be performed by "do-it-yourselfers." Customers should not assume this bulletin applies to their vehicle or that their vehicle will develop the described concern. To determine if the information applies, customers should contact their nearest authorized Mazda dealership. Mazda North American Operations reserves the right to alter the specifications and contents of this bulletin without obligation or advance notice. All rights reserved. No part of this bulletin may be reproduced in any form or by any means, electronic or mechanical---including photocopying and recording and the use of any kind of information storage and retrieval system ---without permission in writing.

2. Stop the engine. Switch OFF the fan motor.
3. Remove the passenger side lower panel and dust filter according to the instructions on MGSS(DUST FILTER REMOVAL/INSTALLATION).



4. Close the passenger side vent, but leave the other vents open.
5. Shake a bottle of the Mazda Air Cooling Coil Coating well and attach it to the applicator, then connect the applicator to compressed shop air.
6. Insert the applicator through the dust filter opening, then into the blower motor air intake opening. Point the nozzle tip downward and outward, and place it along the edge of the blower motor air intake opening.



7. Switch the fan motor ON.
8. Spray the entire contents of the bottle in short bursts, 3 seconds ON, 3 seconds OFF around the outer edge and into the rotating fan. A fine mist may exit from the ducts.
9. When the bottle is empty, remove the applicator and let the fan run for 3 to 5 minutes.

**CONSUMER NOTICE:** The information and instructions in this bulletin are intended for use by skilled technicians. Mazda technicians utilize the proper tools/equipment and take training to correctly and safely maintain Mazda vehicles. These instructions should not be performed by "do-it-yourselfers." Customers should not assume this bulletin applies to their vehicle or that their vehicle will develop the described concern. To determine if the information applies, customers should contact their nearest authorized Mazda dealership. Mazda North American Operations reserves the right to alter the specifications and contents of this bulletin without obligation or advance notice. All rights reserved. No part of this bulletin may be reproduced in any form or by any means, electronic or mechanical---including photocopying and recording and the use of any kind of information storage and retrieval system ---without permission in writing.

**NOTE:** For reuse, clean the applicator by flushing a bottle of clean water through it.

10. Reinstall the dust filter and cover according to the instructions on MGSS (DUST FILTER REMOVAL/INSTALLATION). Replace if needed.

11. Reinstall the passenger side lower panel(PASSENGER-SIDE LOWER PANEL REMOVAL/INSTALLATION)according to the instructions on MGSS.

12. Note application date in service record.

**CONSUMER NOTICE:** The information and instructions in this bulletin are intended for use by skilled technicians. Mazda technicians utilize the proper tools/equipment and take training to correctly and safely maintain Mazda vehicles. These instructions should not be performed by "do-it-yourselfers." Customers should not assume this bulletin applies to their vehicle or that their vehicle will develop the described concern. To determine if the information applies, customers should contact their nearest authorized Mazda dealership. Mazda North American Operations reserves the right to alter the specifications and contents of this bulletin without obligation or advance notice. All rights reserved. No part of this bulletin may be reproduced in any form or by any means, electronic or mechanical---including photocopying and recording and the use of any kind of information storage and retrieval system ---without permission in writing.

## 2016-2018 CX-9 Front A/C

1. Dry the evaporators using the following procedure:

**WARNING:** Running the engine inside an enclosed area, such as a garage, is dangerous. Exhaust gas, which contains poisonous carbon monoxide, could easily enter the cabin. Loss of consciousness or even death could occur. Don't run the engine when inside an enclosed area.

a. Start the engine.

b. Set the HVAC controls as follows.

- RECIRCULATE (1)
- FULL HEAT (front and rear) (2)
- FAN HIGH (front and rear) (3)
- A/C OFF (4)
- AIRFLOW - FACE (front and rear) (5)

### FRONT CLIMATE CONTROL

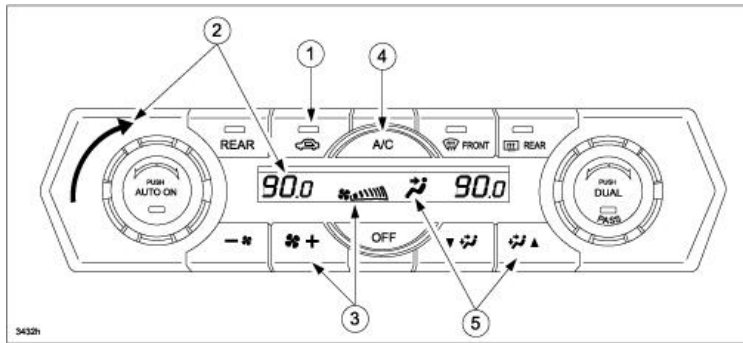

### REAR CLIMATE CONTROL

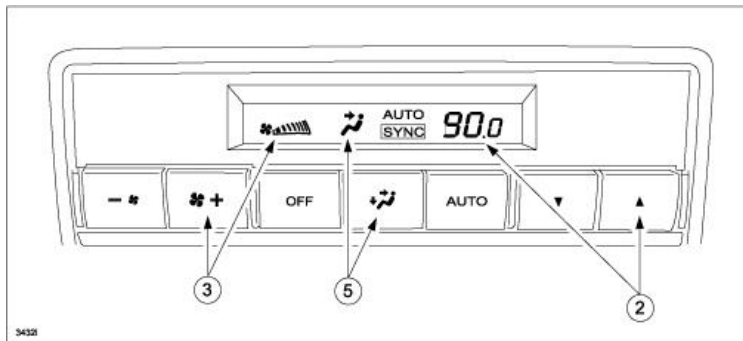

c. Open one window approximately one half inch.

d. Let the engine run for 15 minutes.

**CONSUMER NOTICE:** The information and instructions in this bulletin are intended for use by skilled technicians. Mazda technicians utilize the proper tools/equipment and take training to correctly and safely maintain Mazda vehicles. These instructions should not be performed by "do-it-yourselfers." Customers should not assume this bulletin applies to their vehicle or that their vehicle will develop the described concern. To determine if the information applies, customers should contact their nearest authorized Mazda dealership. Mazda North American Operations reserves the right to alter the specifications and contents of this bulletin without obligation or advance notice. All rights reserved. No part of this bulletin may be reproduced in any form or by any means, electronic or mechanical---including photocopying and recording and the use of any kind of information storage and retrieval system ---without permission in writing.

2. Stop the engine. Switch OFF the fan motor.
3. Remove the glove compartment and cabin air filter according to the instructions on MGSS ([AIR FILTER REMOVAL/INSTALLATION](#)).



4. Close the passenger side vent, but leave the other vents open.
5. Shake a bottle of the Mazda Air Cooling Coil Coating well and attach it to the applicator, then connect the applicator to compressed shop air.
6. Insert the applicator through the the cabin air filter opening, then into the blower motor air intake opening. Point the nozzle tip downward and outward, and place it along the edge of the blower motor air intake opening.



7. Switch the fan motor ON.
8. Spray the entire contents of the bottle in short bursts, 3 seconds ON, 3 seconds OFF around the outer edge and into the rotating fan. A fine mist may exit from the ducts.
9. When the bottle is empty, remove the applicator and let the fan run for 3 to 5 minutes.  
**NOTE:** For reuse, clean the applicator by flushing a bottle of clean water through it.
10. Reinstall the cabin air filter and cover according to the instructions on MGSS ([AIR FILTER REMOVAL/INSTALLATION](#)). Replace if needed.

**CONSUMER NOTICE:** The information and instructions in this bulletin are intended for use by skilled technicians. Mazda technicians utilize the proper tools/equipment and take training to correctly and safely maintain Mazda vehicles. These instructions should not be performed by "do-it-yourselfers." Customers should not assume this bulletin applies to their vehicle or that their vehicle will develop the described concern. To determine if the information applies, customers should contact their nearest authorized Mazda dealership. Mazda North American Operations reserves the right to alter the specifications and contents of this bulletin without obligation or advance notice. All rights reserved. No part of this bulletin may be reproduced in any form or by any means, electronic or mechanical---including photocopying and recording and the use of any kind of information storage and retrieval system ---without permission in writing.



11. Reinstall the glove compartment according to the instructions on MGSS (GLOVE COMPARTMENT REMOVAL/INSTALLATION).

12. Note application date in service record.

**CONSUMER NOTICE:** The information and instructions in this bulletin are intended for use by skilled technicians. Mazda technicians utilize the proper tools/equipment and take training to correctly and safely maintain Mazda vehicles. These instructions should not be performed by "do-it-yourselfers." Customers should not assume this bulletin applies to their vehicle or that their vehicle will develop the described concern. To determine if the information applies, customers should contact their nearest authorized Mazda dealership. Mazda North American Operations reserves the right to alter the specifications and contents of this bulletin without obligation or advance notice. All rights reserved. No part of this bulletin may be reproduced in any form or by any means, electronic or mechanical---including photocopying and recording and the use of any kind of information storage and retrieval system ---without permission in writing.

**2016-2018 CX-9 Rear A/C**

1. Remove the rear console according the instructions on MGSS (REAR CONSOLE REMOVAL/INSTALLATION).
2. Attach the rear climate control connector to the console so that the rear climate control will operate.
3. Put duct tape over the fan opening, and then cut a slit in the duct tape to put the applicator through.



4. Shake a bottle of the Mazda Air Cooling Coil Coating well and attach it to the applicator, then connect the applicator to compressed shop air.
  5. Insert the applicator inside the hole. Point the nozzle tip in direction of the evaporator.
  6. Switch the rear fan motor ON.
  7. Spray the entire contents of the bottle in short bursts, 3 seconds ON, 3 seconds OFF moving up and down and side to side across the evaporator. A fine mist may exit from the ducts.
  8. When the bottle is empty, remove the applicator and let the fan run for 3 to 5 minutes.
- NOTE:** For reuse, clean the applicator by flushing a bottle of clean water through it.
9. While the product is drying, reinstall the rear console according the instructions on MGSS (REAR CONSOLE REMOVAL/INSTALLATION).
  10. Note application date in service record.

**CONSUMER NOTICE:** The information and instructions in this bulletin are intended for use by skilled technicians. Mazda technicians utilize the proper tools/equipment and take training to correctly and safely maintain Mazda vehicles. These instructions should not be performed by "do-it-yourselfers." Customers should not assume this bulletin applies to their vehicle or that their vehicle will develop the described concern. To determine if the information applies, customers should contact their nearest authorized Mazda dealership. Mazda North American Operations reserves the right to alter the specifications and contents of this bulletin without obligation or advance notice. All rights reserved. No part of this bulletin may be reproduced in any form or by any means, electronic or mechanical---including photocopying and recording and the use of any kind of information storage and retrieval system ---without permission in writing.

**2013-2018 CX-5 / 2014-2018 Mazda3 / 2014-2018 Mazda6**

1. Dry the evaporator using the following procedure:

**WARNING:** Running the engine inside an enclosed area, such as a garage, is dangerous. Exhaust gas, which contains poisonous carbon monoxide, could easily enter the cabin. Loss of consciousness or even death could occur. Don't run the engine when inside an enclosed area.

a. Start the engine.

b. Set the HVAC controls as follows.

- RECIRCULATE (1)
- FULL HEAT (2)
- FAN HIGH (3)
- A/C OFF (4)
- AIRFLOW (FACE) (5)

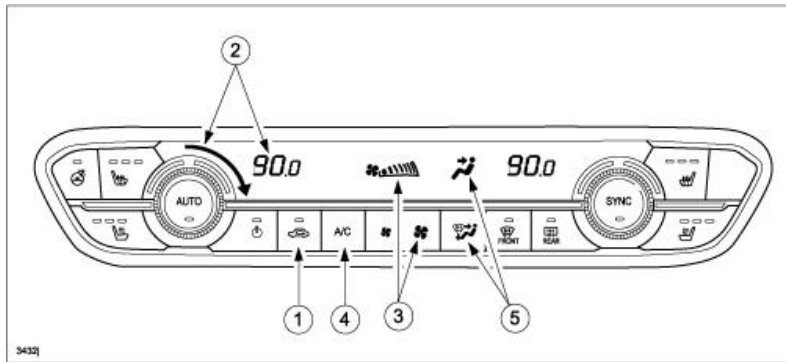
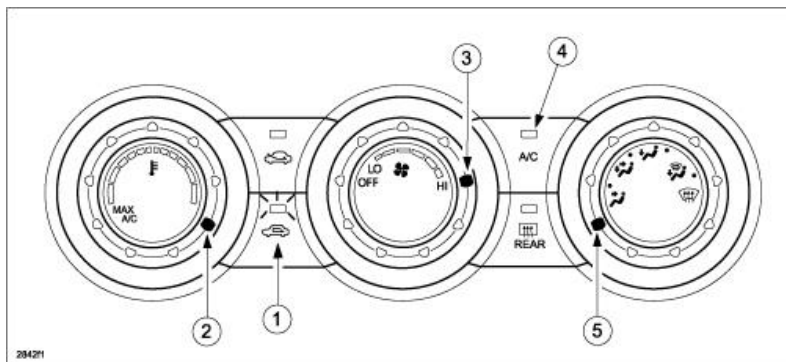
**2018 Mazda6****2014-2017 Mazda6  
MANUAL TYPE**

**CONSUMER NOTICE:** The information and instructions in this bulletin are intended for use by skilled technicians. Mazda technicians utilize the proper tools/equipment and take training to correctly and safely maintain Mazda vehicles. These instructions should not be performed by "do-it-yourselfers." Customers should not assume this bulletin applies to their vehicle or that their vehicle will develop the described concern. To determine if the information applies, customers should contact their nearest authorized Mazda dealership. Mazda North American Operations reserves the right to alter the specifications and contents of this bulletin without obligation or advance notice. All rights reserved. No part of this bulletin may be reproduced in any form or by any means, electronic or mechanical---including photocopying and recording and the use of any kind of information storage and retrieval system ---without permission in writing.

AUTOMATIC TYPE

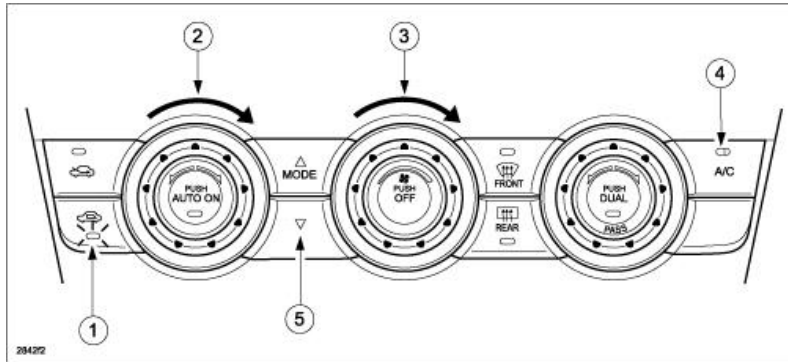

Mazda3  
MANUAL TYPE

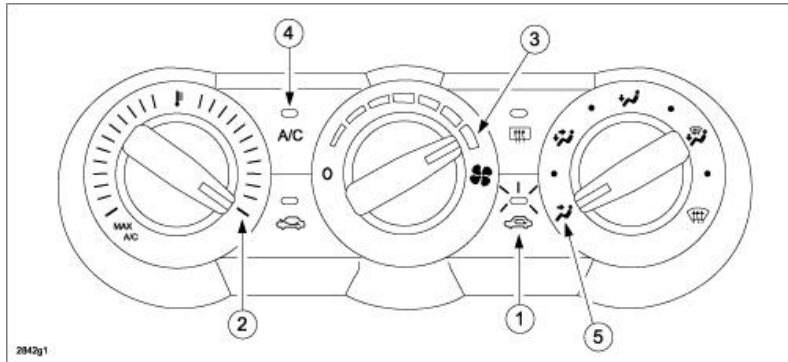

AUTOMATIC TYPE

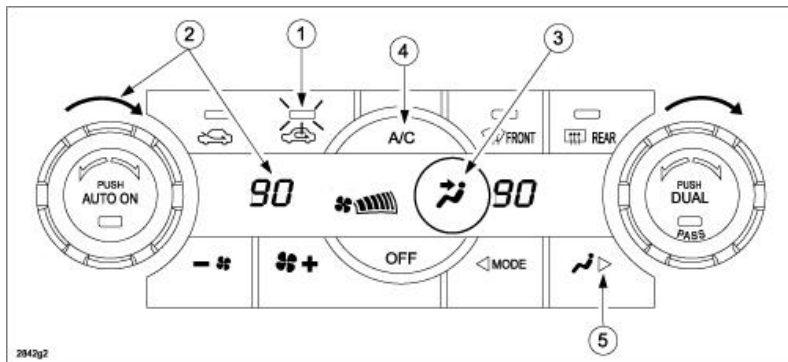

**CONSUMER NOTICE:** The information and instructions in this bulletin are intended for use by skilled technicians. Mazda technicians utilize the proper tools/equipment and take training to correctly and safely maintain Mazda vehicles. These instructions should not be performed by "do-it-yourselfers." Customers should not assume this bulletin applies to their vehicle or that their vehicle will develop the described concern. To determine if the information applies, customers should contact their nearest authorized Mazda dealership. Mazda North American Operations reserves the right to alter the specifications and contents of this bulletin without obligation or advance notice. All rights reserved. No part of this bulletin may be reproduced in any form or by any means, electronic or mechanical---including photocopying and recording and the use of any kind of information storage and retrieval system ---without permission in writing.

2017-2018 CX-5  
MANUAL TYPE

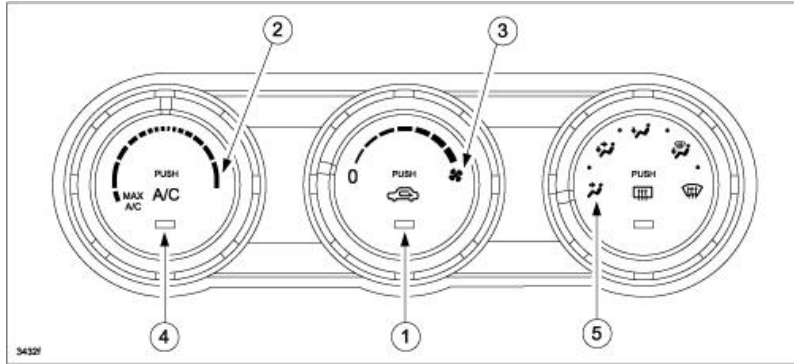

AUTOMATIC TYPE

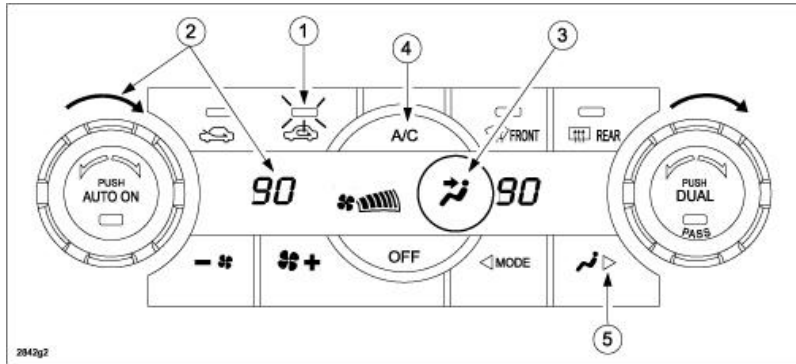

2013-2016 CX-5  
MANUAL TYPE

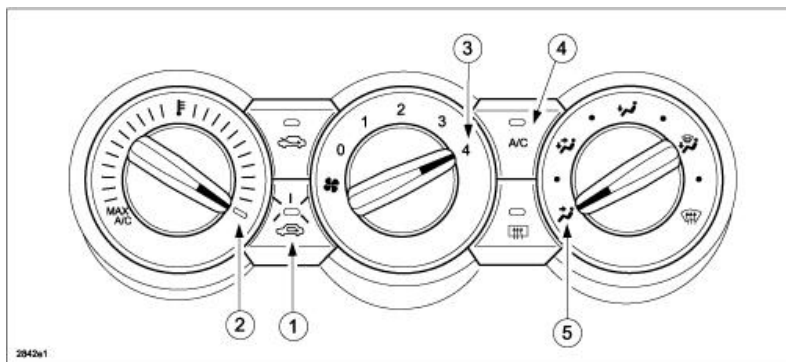

**CONSUMER NOTICE:** The information and instructions in this bulletin are intended for use by skilled technicians. Mazda technicians utilize the proper tools/equipment and take training to correctly and safely maintain Mazda vehicles. These instructions should not be performed by "do-it-yourselfers." Customers should not assume this bulletin applies to their vehicle or that their vehicle will develop the described concern. To determine if the information applies, customers should contact their nearest authorized Mazda dealership. Mazda North American Operations reserves the right to alter the specifications and contents of this bulletin without obligation or advance notice. All rights reserved. No part of this bulletin may be reproduced in any form or by any means, electronic or mechanical---including photocopying and recording and the use of any kind of information storage and retrieval system ---without permission in writing.

## AUTOMATIC TYPE

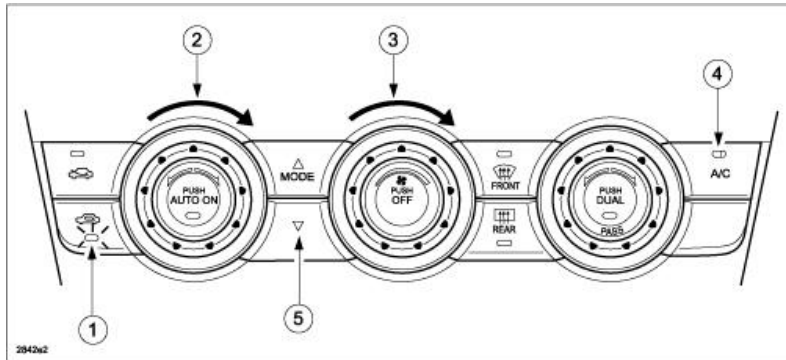

- c. Open one window approximately one half inch.
- d. Let the engine run for 15 minutes.
2. Stop the engine. Switch OFF the fan motor.
3. Remove the glove compartment. Refer to MGSS online instructions.
4. Remove the cabin air filter.

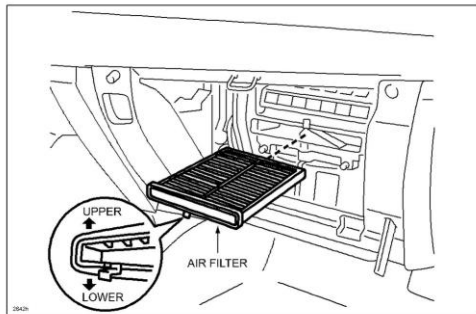

5. Close the passenger side vent, but leave the other vents open.
6. Shake a bottle of the Mazda Air Cooling Coil Coating well and attach it to the applicator, then connect the applicator to compressed shop air.

**CONSUMER NOTICE:** The information and instructions in this bulletin are intended for use by skilled technicians. Mazda technicians utilize the proper tools/equipment and take training to correctly and safely maintain Mazda vehicles. These instructions should not be performed by "do-it-yourselfers." Customers should not assume this bulletin applies to their vehicle or that their vehicle will develop the described concern. To determine if the information applies, customers should contact their nearest authorized Mazda dealership. Mazda North American Operations reserves the right to alter the specifications and contents of this bulletin without obligation or advance notice. All rights reserved. No part of this bulletin may be reproduced in any form or by any means, electronic or mechanical---including photocopying and recording and the use of any kind of information storage and retrieval system ---without permission in writing.

7. Insert the applicator through the the cabin air filter opening, then into the blower motor air intake opening. Point the nozzle tip downward and outward, and place it along the edge of the blower motor air intake opening.

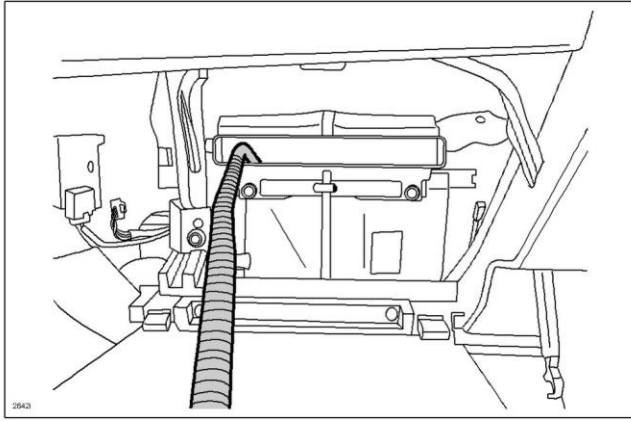

8. Switch the fan motor ON.

9. Spray the entire contents of the bottle in short bursts, 3 seconds ON, 3 seconds OFF around the outer edge and into the rotating fan. A fine mist may exit from the ducts.

10. When the bottle is empty, remove the applicator and let the fan run for 3 to 5 minutes.

**NOTE:** For reuse, clean the applicator by flushing a bottle of clean water through it.

11. Reinstall the cabin air filter. Replace if needed.

12. Reinstall the glove box.

13. Note application date in service record.

**2007-2015 CX-9 Front A/C**

1. Dry the evaporators using the following procedure:

**WARNING:** Running the engine inside an enclosed area, such as a garage, is dangerous. Exhaust gas, which contains poisonous carbon monoxide, could easily enter the cabin. Loss of consciousness or even death could occur. Don't run the engine when inside an enclosed area.

a. Start the engine.

b. Set the HVAC controls as follows.

- RECIRCULATE
- FULL HEAT (front and rear)
- FAN HIGH (front and rear)
- A/C OFF
- AIRFLOW - FACE (front and rear)

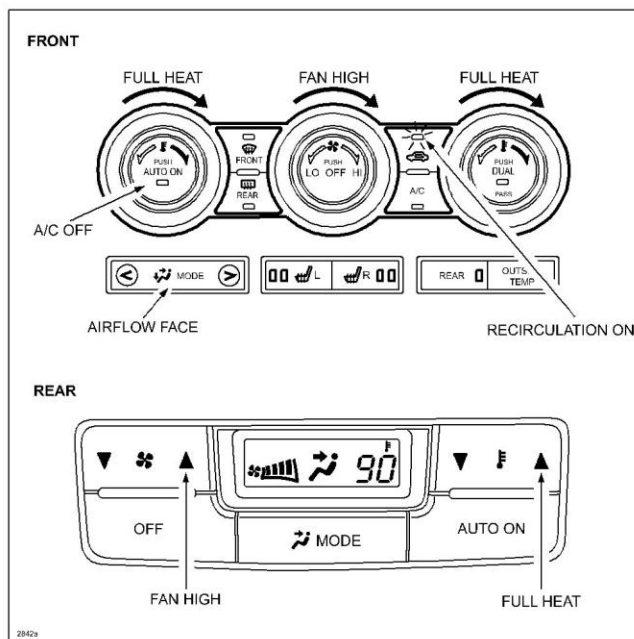
**2013-2015 CX-9**

**CONSUMER NOTICE:** The information and instructions in this bulletin are intended for use by skilled technicians. Mazda technicians utilize the proper tools/equipment and take training to correctly and safely maintain Mazda vehicles. These instructions should not be performed by "do-it-yourselfers." Customers should not assume this bulletin applies to their vehicle or that their vehicle will develop the described concern. To determine if the information applies, customers should contact their nearest authorized Mazda dealership. Mazda North American Operations reserves the right to alter the specifications and contents of this bulletin without obligation or advance notice. All rights reserved. No part of this bulletin may be reproduced in any form or by any means, electronic or mechanical---including photocopying and recording and the use of any kind of information storage and retrieval system ---without permission in writing.



2007-2012 CX-9

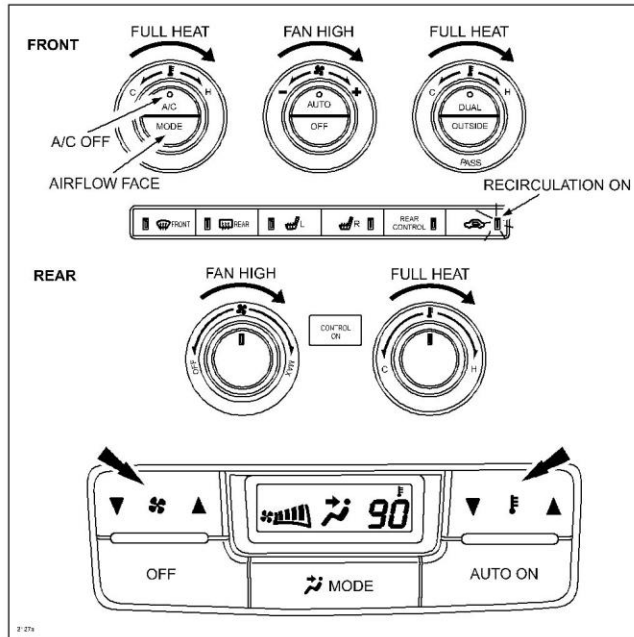

- c. Open one window approximately one half inch.
  - d. Let the engine run for 15 minutes.
2. Remove the glove compartment service hole cover, then remove the cabin air filter cover in the direction of the arrow.

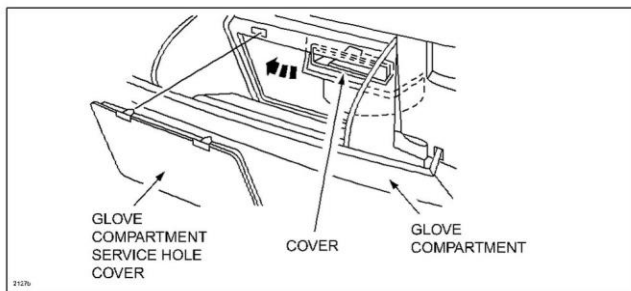

- 3. Stop the engine. Switch OFF the fan motor.
- 4. Remove the cabin air filter.

**CONSUMER NOTICE:** The information and instructions in this bulletin are intended for use by skilled technicians. Mazda technicians utilize the proper tools/equipment and take training to correctly and safely maintain Mazda vehicles. These instructions should not be performed by "do-it-yourselfers." Customers should not assume this bulletin applies to their vehicle or that their vehicle will develop the described concern. To determine if the information applies, customers should contact their nearest authorized Mazda dealership. Mazda North American Operations reserves the right to alter the specifications and contents of this bulletin without obligation or advance notice. All rights reserved. No part of this bulletin may be reproduced in any form or by any means, electronic or mechanical---including photocopying and recording and the use of any kind of information storage and retrieval system ---without permission in writing.

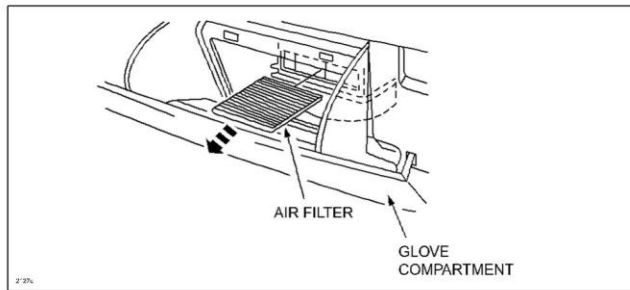

5. Close the passenger side vent, but leave the other vents open.
6. Shake a bottle of the Mazda Air Cooling Coil Coating well and attach it to the applicator, then connect the applicator to compressed shop air.
7. Insert the applicator through the the cabin air filter opening, then into the blower motor air intake opening. Point the nozzle tip downward and outward, and place it along the edge of the blower motor air intake opening.

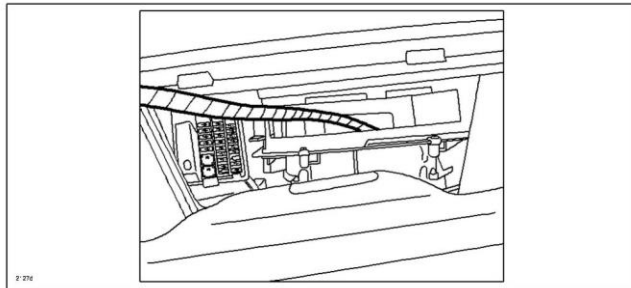

8. Switch the fan motor ON.
9. Spray the entire contents of the bottle in short bursts, 3 seconds ON, 3 seconds OFF around the outer edge and into the rotating fan. A fine mist may exit from the ducts.
10. When the bottle is empty, remove the applicator and let the fan run for 3 to 5 minutes.

**NOTE:** For reuse, clean the applicator by flushing a bottle of clean water through it.

11. Reinstall the cabin air filter. and cover. Replace if needed.
12. Reinstall the glove compartment service hole cover.
13. Note application date in service record.

**CONSUMER NOTICE:** The information and instructions in this bulletin are intended for use by skilled technicians. Mazda technicians utilize the proper tools/equipment and take training to correctly and safely maintain Mazda vehicles. These instructions should not be performed by "do-it-yourselfers." Customers should not assume this bulletin applies to their vehicle or that their vehicle will develop the described concern. To determine if the information applies, customers should contact their nearest authorized Mazda dealership. Mazda North American Operations reserves the right to alter the specifications and contents of this bulletin without obligation or advance notice. All rights reserved. No part of this bulletin may be reproduced in any form or by any means, electronic or mechanical---including photocopying and recording and the use of any kind of information storage and retrieval system ---without permission in writing.

**2007-2015 CX-9 Rear A/C**

1. Remove the console according to the instructions on MGSS.
2. Attach the rear connector to the console cover so that the rear climate control will operate.

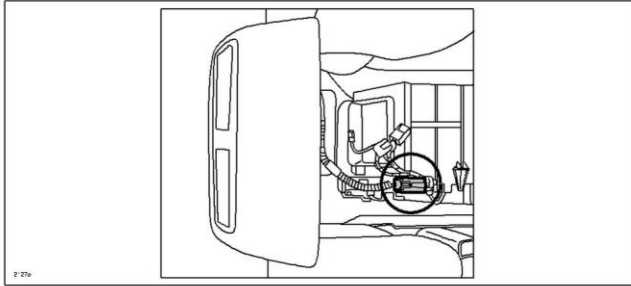

3. Remove the Power MOS FET, but do not disconnect.

**WARNING:** Power MOS FET may be extremely hot.

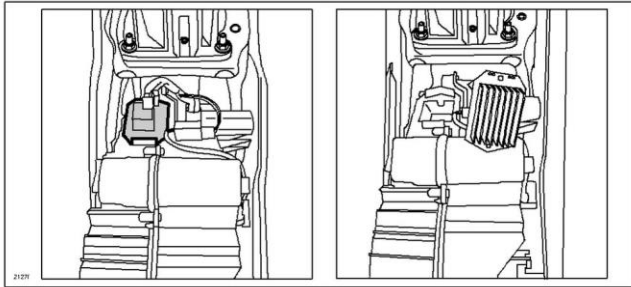

4. Put duct tape over the Power MOS FET opening, and then cut a slit in the duct tape to put the applicator through.

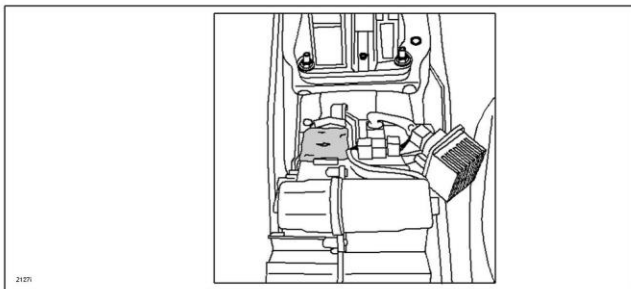

5. Shake a bottle of the Mazda Air Cooling Coil Coating well and attach it to the applicator, then connect the applicator to compressed shop air.

**CONSUMER NOTICE:** The information and instructions in this bulletin are intended for use by skilled technicians. Mazda technicians utilize the proper tools/equipment and take training to correctly and safely maintain Mazda vehicles. These instructions should not be performed by "do-it-yourselfers." Customers should not assume this bulletin applies to their vehicle or that their vehicle will develop the described concern. To determine if the information applies, customers should contact their nearest authorized Mazda dealership. Mazda North American Operations reserves the right to alter the specifications and contents of this bulletin without obligation or advance notice. All rights reserved. No part of this bulletin may be reproduced in any form or by any means, electronic or mechanical---including photocopying and recording and the use of any kind of information storage and retrieval system ---without permission in writing.

6. Insert the applicator inside the hole. Point the nozzle tip in direction of the evaporator.

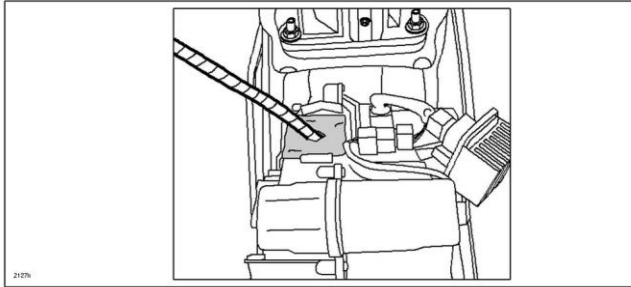

7. Switch the rear fan motor ON.
8. Spray the entire contents of the bottle in short bursts, 3 seconds ON, 3 seconds OFF moving up and down and side to side across the evaporator. A fine mist may exit from the ducts.
9. When the bottle is empty, remove the applicator and let the fan run for 3 to 5 minutes.  
**NOTE:** For reuse, clean the applicator by flushing a bottle of clean water through it.
10. While the product is drying, re-install the removed parts.
11. Note application date in service record.

**CONSUMER NOTICE:** The information and instructions in this bulletin are intended for use by skilled technicians. Mazda technicians utilize the proper tools/equipment and take training to correctly and safely maintain Mazda vehicles. These instructions should not be performed by "do-it-yourselfers." Customers should not assume this bulletin applies to their vehicle or that their vehicle will develop the described concern. To determine if the information applies, customers should contact their nearest authorized Mazda dealership. Mazda North American Operations reserves the right to alter the specifications and contents of this bulletin without obligation or advance notice. All rights reserved. No part of this bulletin may be reproduced in any form or by any means, electronic or mechanical---including photocopying and recording and the use of any kind of information storage and retrieval system ---without permission in writing.

**2011-2014 Mazda2**

1. Dry the evaporator using the following procedure:

**WARNING:** Running the engine inside an enclosed area, such as a garage, is dangerous. Exhaust gas, which contains poisonous carbon monoxide, could easily enter the cabin. Loss of consciousness or even death could occur. Don't run the engine when inside an enclosed area.

a. Start the engine.

b. Set the HVAC controls as follows.

- RECIRCULATE
- FULL HEAT
- FAN HIGH
- A/C OFF
- AIRFLOW (FACE)

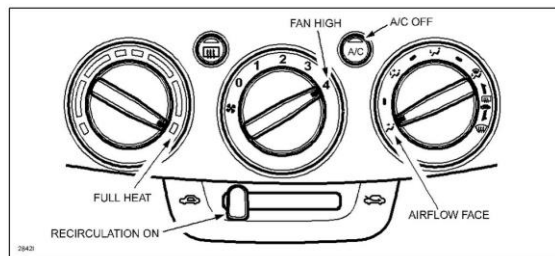

c. Open one window approximately one half inch.

d. Let the engine run for 15 minutes.

2. Stop the engine. Switch OFF the fan motor.

3. Remove the cabin air filter cover, then remove the cabin air filters.

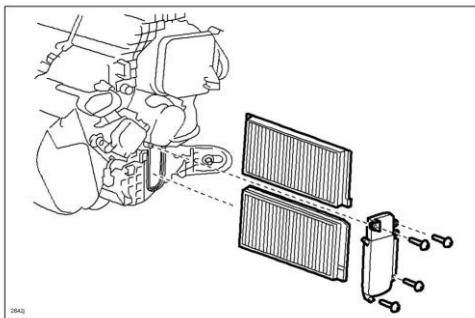

4. Close the passenger side vent, but leave the other vents open.

**CONSUMER NOTICE:** The information and instructions in this bulletin are intended for use by skilled technicians. Mazda technicians utilize the proper tools/equipment and take training to correctly and safely maintain Mazda vehicles. These instructions should not be performed by "do-it-yourselfers." Customers should not assume this bulletin applies to their vehicle or that their vehicle will develop the described concern. To determine if the information applies, customers should contact their nearest authorized Mazda dealership. Mazda North American Operations reserves the right to alter the specifications and contents of this bulletin without obligation or advance notice. All rights reserved. No part of this bulletin may be reproduced in any form or by any means, electronic or mechanical---including photocopying and recording and the use of any kind of information storage and retrieval system ---without permission in writing.

5. Shake a bottle of the Mazda Air Cooling Coil Coating well and attach it to the applicator, then connect the applicator to compressed shop air.
6. Insert the applicator through the the cabin air filter opening, then into the blower motor air intake opening. Point the nozzle tip downward and outward, and place it along the edge of the blower motor air intake opening.

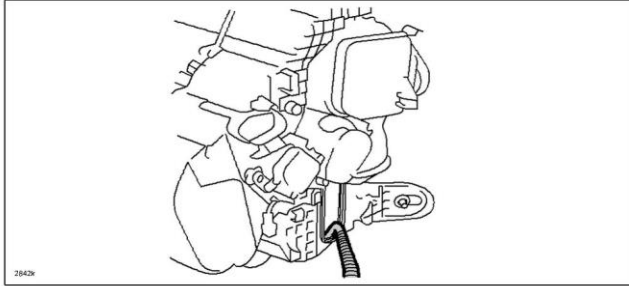

7. Switch the fan motor ON.
  8. Spray the entire contents of the bottle in short bursts, 3 seconds ON, 3 seconds OFF around the outer edge and into the rotating fan. A fine mist may exit from the ducts.
  9. When the bottle is empty, remove the applicator and let the fan run for 3 to 5 minutes.
- NOTE:** For reuse, clean the applicator by flushing a bottle of clean water through it.
10. Reinstall the cabin air filters and cabin air filter cover. Replace if needed.
  11. Note application date in service record.

**CONSUMER NOTICE:** The information and instructions in this bulletin are intended for use by skilled technicians. Mazda technicians utilize the proper tools/equipment and take training to correctly and safely maintain Mazda vehicles. These instructions should not be performed by "do-it-yourselfers." Customers should not assume this bulletin applies to their vehicle or that their vehicle will develop the described concern. To determine if the information applies, customers should contact their nearest authorized Mazda dealership. Mazda North American Operations reserves the right to alter the specifications and contents of this bulletin without obligation or advance notice. All rights reserved. No part of this bulletin may be reproduced in any form or by any means, electronic or mechanical---including photocopying and recording and the use of any kind of information storage and retrieval system ---without permission in writing.

**2007-2012 CX-7**

1. Dry the evaporator using the following procedure:

**WARNING:** Running the engine inside an enclosed area, such as a garage, is dangerous. Exhaust gas, which contains poisonous carbon monoxide, could easily enter the cabin. Loss of consciousness or even death could occur. Don't run the engine when inside an enclosed area.

a. Start the engine.

b. Set the HVAC controls as follows.

- RECIRCULATE
- FULL HEAT
- FAN HIGH
- A/C OFF
- AIRFLOW (FACE)

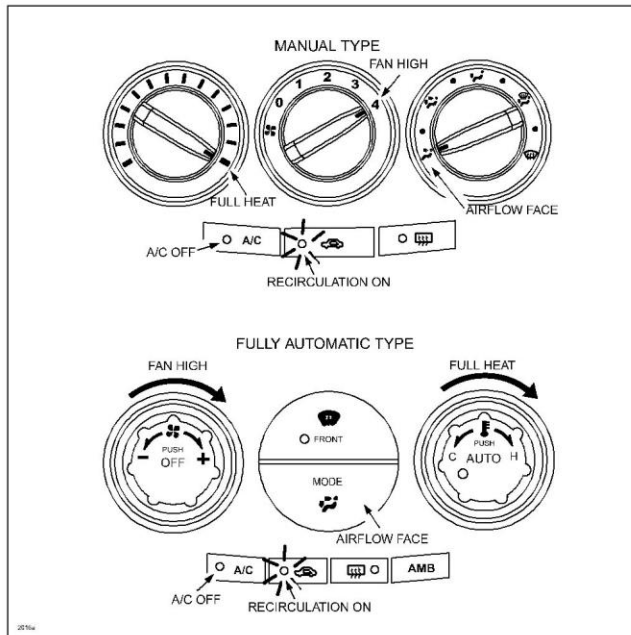

c. Open one window approximately one half inch.

d. Let the engine run for 15 minutes.

2. Remove the glove box. Refer to MGSS online instructions or Workshop Manual section 09-17.

3. Stop the engine. Switch OFF the fan motor.

**CONSUMER NOTICE:** The information and instructions in this bulletin are intended for use by skilled technicians. Mazda technicians utilize the proper tools/equipment and take training to correctly and safely maintain Mazda vehicles. These instructions should not be performed by "do-it-yourselfers." Customers should not assume this bulletin applies to their vehicle or that their vehicle will develop the described concern. To determine if the information applies, customers should contact their nearest authorized Mazda dealership. Mazda North American Operations reserves the right to alter the specifications and contents of this bulletin without obligation or advance notice. All rights reserved. No part of this bulletin may be reproduced in any form or by any means, electronic or mechanical---including photocopying and recording and the use of any kind of information storage and retrieval system ---without permission in writing.

4. Remove the cabin air filter cover, then the filter.

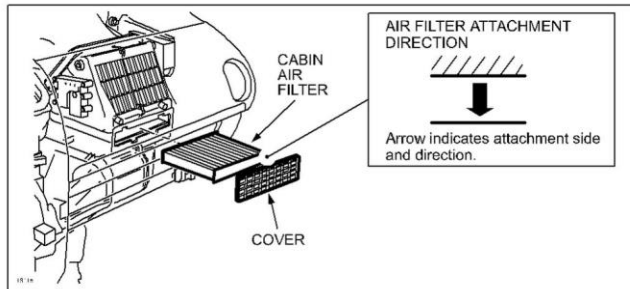

5. Close the passenger side vent, but leave the other vents open.

6. Shake a bottle of the Mazda Air Cooling Coil Coating well and attach it to the applicator, then connect the applicator to compressed shop air.

7. Insert the applicator through the the cabin air filter opening, then into the blower motor air intake opening. Point the nozzle tip downward and outward, and place it along the edge of the blower motor air intake opening.

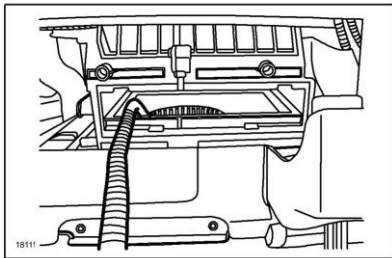

8. Switch the fan motor ON.

9. Spray the entire contents of the bottle in short bursts, 3 seconds ON, 3 seconds OFF around the outer edge and into the rotating fan. A fine mist may exit from the ducts.

10. When the bottle is empty, remove the applicator and let the fan run for 3 to 5 minutes.

**NOTE:** For reuse, clean the applicator by flushing a bottle of clean water through it.

11. Reinstall the cabin air filter. Replace if needed.

12. Reinstall the glove box.

13. Note application date in service record.

**CONSUMER NOTICE:** The information and instructions in this bulletin are intended for use by skilled technicians. Mazda technicians utilize the proper tools/equipment and take training to correctly and safely maintain Mazda vehicles. These instructions should not be performed by "do-it-yourselfers." Customers should not assume this bulletin applies to their vehicle or that their vehicle will develop the described concern. To determine if the information applies, customers should contact their nearest authorized Mazda dealership. Mazda North American Operations reserves the right to alter the specifications and contents of this bulletin without obligation or advance notice. All rights reserved. No part of this bulletin may be reproduced in any form or by any means, electronic or mechanical---including photocopying and recording and the use of any kind of information storage and retrieval system ---without permission in writing.



**2003-2013 Mazda6**

1. Dry the evaporator using the following procedure:

**WARNING:** Running the engine inside an enclosed area, such as a garage, is dangerous. Exhaust gas, which contains poisonous carbon monoxide, could easily enter the cabin. Loss of consciousness or even death could occur. Don't run the engine when inside an enclosed area.

a. Start the engine.

b. Set the HVAC controls as follows.

- RECIRCULATE
- FULL HEAT
- FAN HIGH
- A/C OFF
- AIRFLOW (FACE)

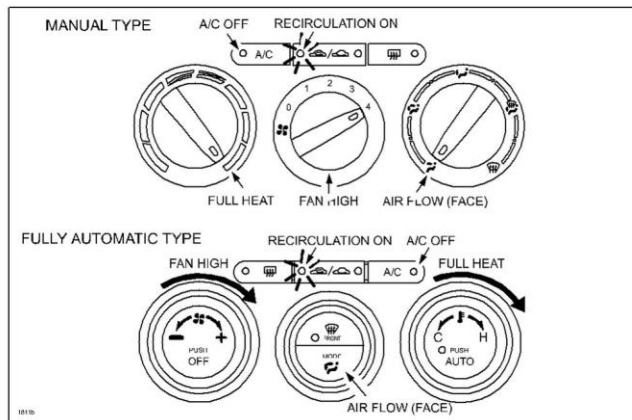
**2003-2008 Mazda6 Climate Controls**

**CONSUMER NOTICE:** The information and instructions in this bulletin are intended for use by skilled technicians. Mazda technicians utilize the proper tools/equipment and take training to correctly and safely maintain Mazda vehicles. These instructions should not be performed by "do-it-yourselfers." Customers should not assume this bulletin applies to their vehicle or that their vehicle will develop the described concern. To determine if the information applies, customers should contact their nearest authorized Mazda dealership. Mazda North American Operations reserves the right to alter the specifications and contents of this bulletin without obligation or advance notice. All rights reserved. No part of this bulletin may be reproduced in any form or by any means, electronic or mechanical---including photocopying and recording and the use of any kind of information storage and retrieval system ---without permission in writing.

## 2009-2013 Mazda6 Climate Controls

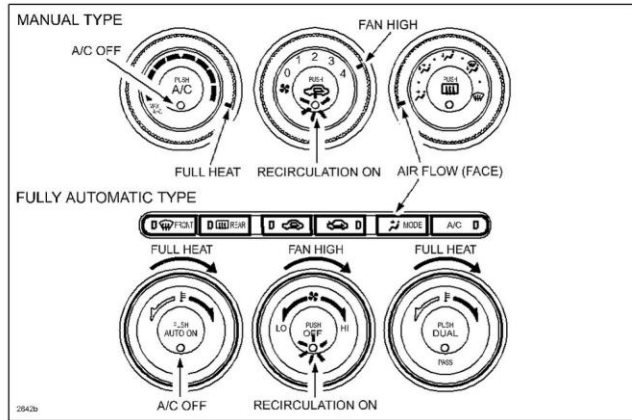

- c. Open one window approximately one half inch.
- d. Let the engine run for 15 minutes.
2. Remove the glove box according to the instructions on MGSS.
3. Stop the engine. Switch OFF the fan motor.
4. Remove the cabin air filter cover, then the filter.

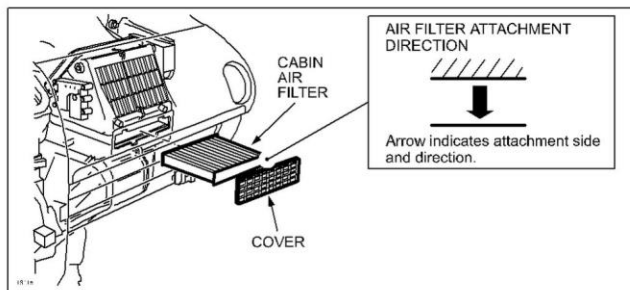

5. Close the passenger side vent, but leave the other vents open.
6. Shake a bottle of the Mazda Air Cooling Coil Coating well and attach it to the applicator, then connect the applicator to compressed shop air.

**CONSUMER NOTICE:** The information and instructions in this bulletin are intended for use by skilled technicians. Mazda technicians utilize the proper tools/equipment and take training to correctly and safely maintain Mazda vehicles. These instructions should not be performed by "do-it-yourselfers." Customers should not assume this bulletin applies to their vehicle or that their vehicle will develop the described concern. To determine if the information applies, customers should contact their nearest authorized Mazda dealership. Mazda North American Operations reserves the right to alter the specifications and contents of this bulletin without obligation or advance notice. All rights reserved. No part of this bulletin may be reproduced in any form or by any means, electronic or mechanical---including photocopying and recording and the use of any kind of information storage and retrieval system ---without permission in writing.

7. Insert the applicator through the the cabin air filter opening, then into the blower motor air intake opening. Point the nozzle tip downward and outward, and place it along the edge of the blower motor air intake opening.

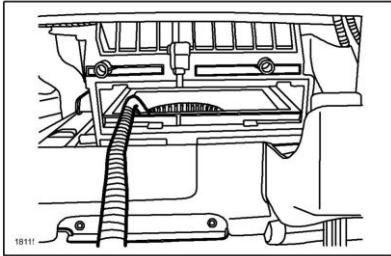

8. Switch the fan motor ON.

9. Spray the entire contents of the bottle in short bursts, 3 seconds ON, 3 seconds OFF around the outer edge and into the rotating fan. A fine mist may exit from the ducts.

10. When the bottle is empty, remove the applicator and let the fan run for 3 to 5 minutes.

**NOTE:** For reuse, clean the applicator by flushing a bottle of clean water through it.

11. Reinstall the cabin air filter. Replace if needed.

12. Reinstall the glove box.

13. Note application date in service record.

**2004-2013 Mazda3 / 2006-2015 Mazda5**

1. Dry the evaporator using the following procedure:

**WARNING:** Running the engine inside an enclosed area, such as a garage, is dangerous. Exhaust gas, which contains poisonous carbon monoxide, could easily enter the cabin. Loss of consciousness or even death could occur. Don't run the engine when inside an enclosed area.

a. Start the engine.

b. Set the HVAC controls as follows.

- RECIRCULATE
- FULL HEAT
- FAN HIGH
- A/C OFF
- AIRFLOW (FACE)

2006-2015 Mazda5

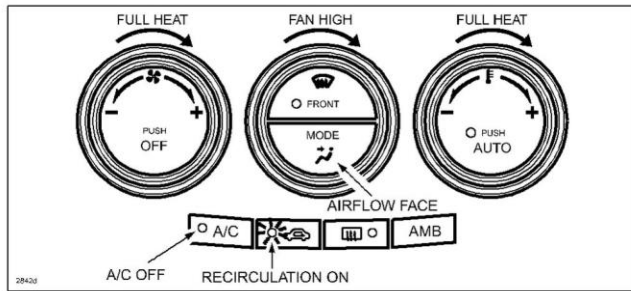

2004-2009 Mazda3

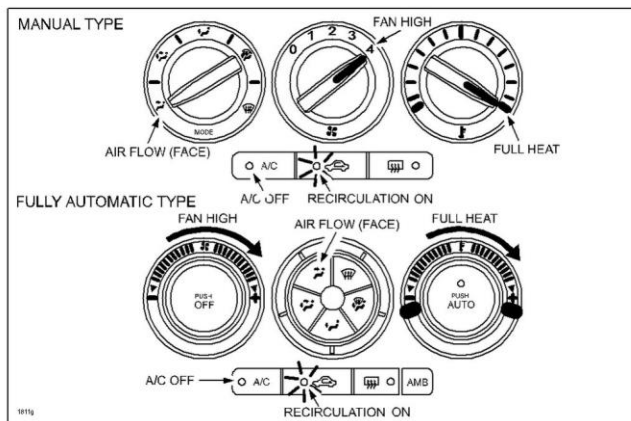

**CONSUMER NOTICE:** The information and instructions in this bulletin are intended for use by skilled technicians. Mazda technicians utilize the proper tools/equipment and take training to correctly and safely maintain Mazda vehicles. These instructions should not be performed by "do-it-yourselfers." Customers should not assume this bulletin applies to their vehicle or that their vehicle will develop the described concern. To determine if the information applies, customers should contact their nearest authorized Mazda dealership. Mazda North American Operations reserves the right to alter the specifications and contents of this bulletin without obligation or advance notice. All rights reserved. No part of this bulletin may be reproduced in any form or by any means, electronic or mechanical---including photocopying and recording and the use of any kind of information storage and retrieval system ---without permission in writing.

## 2010-2013 Mazda3

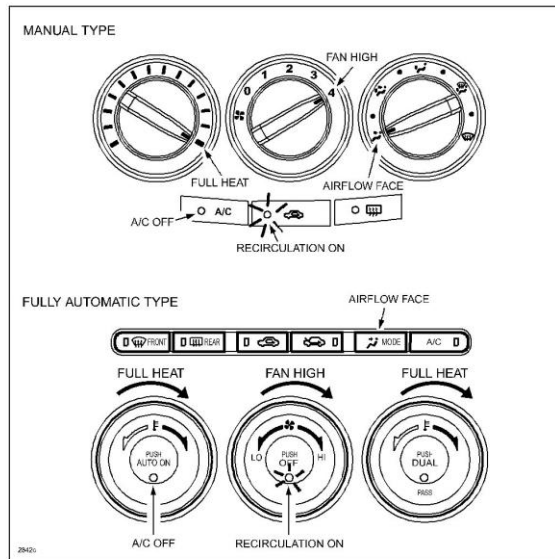

- c. Open one window approximately one half inch.
- d. Let the engine run for 15 minutes.
2. Stop the engine. Switch OFF the fan motor.
3. Record the radio preset stations.
4. Set the ignition to the LOCK position.
5. Disconnect the negative battery cable for 1 minute or more.
6. Remove the console sidewall on the passenger side footwell.

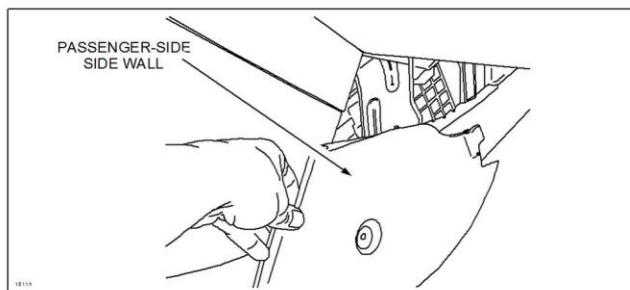

**CONSUMER NOTICE:** The information and instructions in this bulletin are intended for use by skilled technicians. Mazda technicians utilize the proper tools/equipment and take training to correctly and safely maintain Mazda vehicles. These instructions should not be performed by "do-it-yourselfers." Customers should not assume this bulletin applies to their vehicle or that their vehicle will develop the described concern. To determine if the information applies, customers should contact their nearest authorized Mazda dealership. Mazda North American Operations reserves the right to alter the specifications and contents of this bulletin without obligation or advance notice. All rights reserved. No part of this bulletin may be reproduced in any form or by any means, electronic or mechanical---including photocopying and recording and the use of any kind of information storage and retrieval system ---without permission in writing.

7. Remove the PJB and PJB bracket according to the instructions on MGSS ([PASSENGER JUNCTION BOX \(PJB\) REMOVAL/INSTALLATION](#)).

**NOTE:** PJB module configuration does not need to be performed since the same module will be used.

8. Remove the metal bracket.

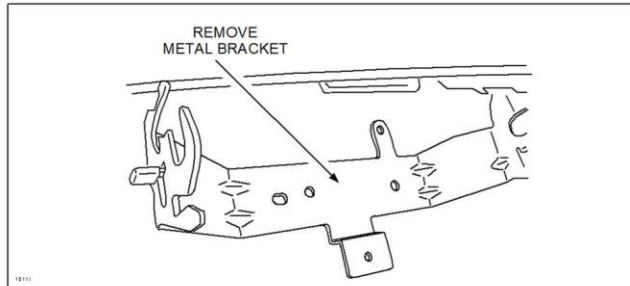

9. Disconnect the evaporator temperature sensor connector.

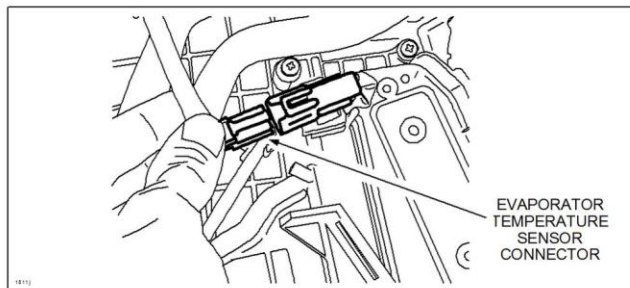

10. Disconnect the the Power MOS FET connector (full-auto climate control).

**WARNING:** Power MOS FET may be extremely hot.

11. Remove the cabin air filter cover, then remove the two cabin air filters.

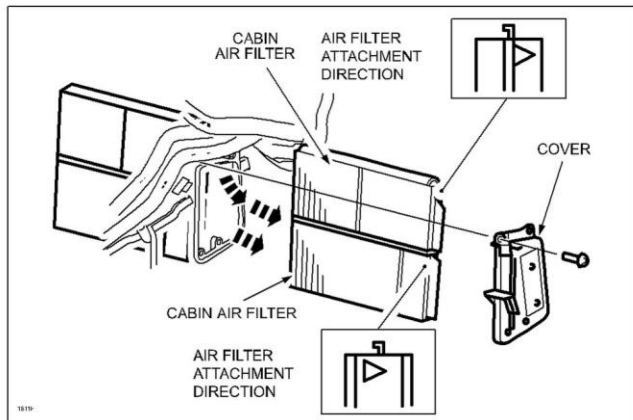

12. Shake a bottle of the Mazda Air Cooling Coil Coating well and attach it to the applicator, then connect the applicator to compressed shop air.

13. Close the passenger side vent, but leave the other vents open.

14. Insert the applicator inside the hole. Point the nozzle tip in direction of the evaporator.

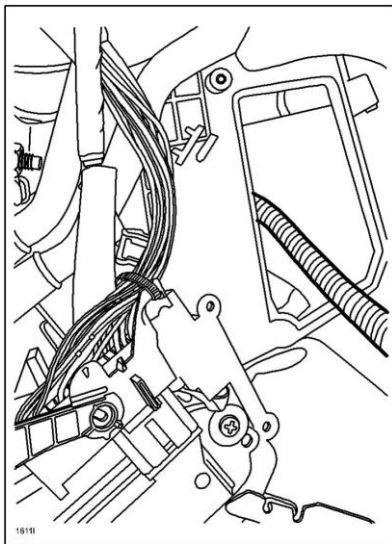

15. Spray the entire contents of the bottle in short bursts, 3 seconds ON, 3 seconds OFF around the outer edge and into the rotating fan. A fine mist may exit from the ducts.

**CONSUMER NOTICE:** The information and instructions in this bulletin are intended for use by skilled technicians. Mazda technicians utilize the proper tools/equipment and take training to correctly and safely maintain Mazda vehicles. These instructions should not be performed by "do-it-yourselfers." Customers should not assume this bulletin applies to their vehicle or that their vehicle will develop the described concern. To determine if the information applies, customers should contact their nearest authorized Mazda dealership. Mazda North American Operations reserves the right to alter the specifications and contents of this bulletin without obligation or advance notice. All rights reserved. No part of this bulletin may be reproduced in any form or by any means, electronic or mechanical---including photocopying and recording and the use of any kind of information storage and retrieval system ---without permission in writing.

16. When the bottle is empty, remove the applicator and let the fan run for 3 to 5 minutes.

**NOTE:** For reuse, clean the applicator by flushing a bottle of clean water through it.

17. Reinstall the cabin air filters. Replace if needed.

18. Install the cabin air filter cover.

19. Connect the Power MOS FET connector.

20. Connect the evaporator temperature sensor connector.

21. Reinstall the metal bracket.

22. Reinstall the PJB and PJB bracket according to the instructions on MGSS ([PASSENGER JUNCTION BOX \(PJB\) REMOVAL/INSTALLATION](#)).

23. Reinstall the console side wall.

24. Note application date in service record.

**CONSUMER NOTICE:** The information and instructions in this bulletin are intended for use by skilled technicians. Mazda technicians utilize the proper tools/equipment and take training to correctly and safely maintain Mazda vehicles. These instructions should not be performed by "do-it-yourselfers." Customers should not assume this bulletin applies to their vehicle or that their vehicle will develop the described concern. To determine if the information applies, customers should contact their nearest authorized Mazda dealership. Mazda North American Operations reserves the right to alter the specifications and contents of this bulletin without obligation or advance notice. All rights reserved. No part of this bulletin may be reproduced in any form or by any means, electronic or mechanical---including photocopying and recording and the use of any kind of information storage and retrieval system ---without permission in writing.



**2006-2015 MX-5**

1. Dry the evaporator using the following procedure:

**WARNING:** Running the engine inside an enclosed area, such as a garage, is dangerous. Exhaust gas, which contains poisonous carbon monoxide, could easily enter the cabin. Loss of consciousness or even death could occur. Don't run the engine when inside an enclosed area.

a. Start the engine.

b. Set the HVAC controls as follows:

- Air source: re-circulate
- Heater control: full heat
- Fan: high
- A/C switch: off

Airflow (Face)

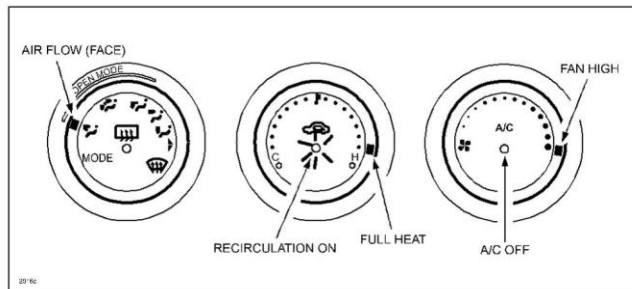

c. Open one window approximately one half inch.

d. Let the engine run for 15 minutes.

**CONSUMER NOTICE:** The information and instructions in this bulletin are intended for use by skilled technicians. Mazda technicians utilize the proper tools/equipment and take training to correctly and safely maintain Mazda vehicles. These instructions should not be performed by "do-it-yourselfers." Customers should not assume this bulletin applies to their vehicle or that their vehicle will develop the described concern. To determine if the information applies, customers should contact their nearest authorized Mazda dealership. Mazda North American Operations reserves the right to alter the specifications and contents of this bulletin without obligation or advance notice. All rights reserved. No part of this bulletin may be reproduced in any form or by any means, electronic or mechanical---including photocopying and recording and the use of any kind of information storage and retrieval system ---without permission in writing.

2. Remove the glove box by:
  - a. Remove the dumper clip.

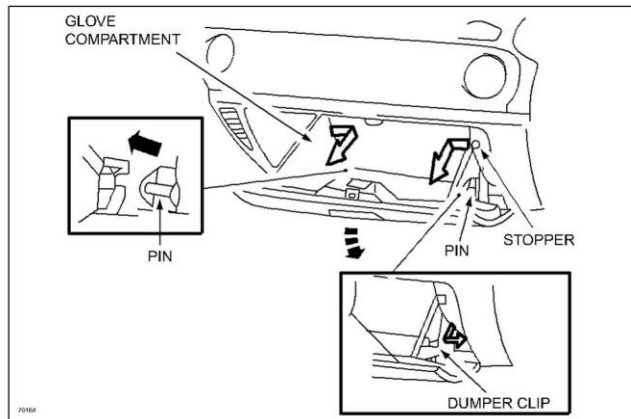

- b. Bend the stoppers inward, then remove.
  - c. Turn the glove compartment downward and pull the pins.
3. Close the passenger side vent, but leave the other vents open.
4. Shake a bottle of Mazda Cooling Coil Coating well and attach it to the applicator, then connect the applicator to compressed shop air.
5. Insert the applicator in the grille of the the recirculation door. Point the nozzle tip downwards and towards center (approximately the 7 o'clock position).

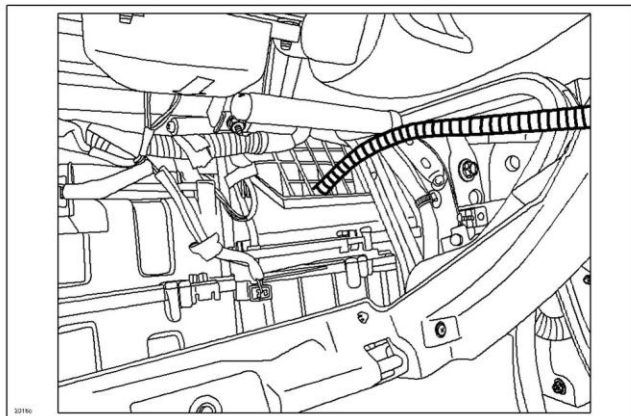

**CONSUMER NOTICE:** The information and instructions in this bulletin are intended for use by skilled technicians. Mazda technicians utilize the proper tools/equipment and take training to correctly and safely maintain Mazda vehicles. These instructions should not be performed by "do-it-yourselfers." Customers should not assume this bulletin applies to their vehicle or that their vehicle will develop the described concern. To determine if the information applies, customers should contact their nearest authorized Mazda dealership. Mazda North American Operations reserves the right to alter the specifications and contents of this bulletin without obligation or advance notice. All rights reserved. No part of this bulletin may be reproduced in any form or by any means, electronic or mechanical---including photocopying and recording and the use of any kind of information storage and retrieval system ---without permission in writing.

6. Spray the entire contents of the bottle in short bursts, 3 seconds ON, 3 seconds OFF into the rotating fan. A fine mist may exit from the ducts.

7. When the bottle is empty, remove the applicator and let the fan run for 3 to 5 minutes.

**NOTE:** Clean the empty bottle by flushing it with clean water.

8. While the product is drying, re-install the glove box.

9. Note application date in service record.

**CONSUMER NOTICE:** The information and instructions in this bulletin are intended for use by skilled technicians. Mazda technicians utilize the proper tools/equipment and take training to correctly and safely maintain Mazda vehicles. These instructions should not be performed by "do-it-yourselfers." Customers should not assume this bulletin applies to their vehicle or that their vehicle will develop the described concern. To determine if the information applies, customers should contact their nearest authorized Mazda dealership. Mazda North American Operations reserves the right to alter the specifications and contents of this bulletin without obligation or advance notice. All rights reserved. No part of this bulletin may be reproduced in any form or by any means, electronic or mechanical---including photocopying and recording and the use of any kind of information storage and retrieval system ---without permission in writing.

**1998-2002 626**

1. Dry the evaporator using the following procedure:

**WARNING:** Running the engine inside an enclosed area, such as a garage, is dangerous. Exhaust gas, which contains poisonous carbon monoxide, could easily enter the cabin. Loss of consciousness or even death could occur. Don't run the engine when inside an enclosed area.

a. Start the engine.

b. Set the HVAC controls as follows:

- RECIRCULATE
- FULL HEAT
- FAN HIGH
- A/C OFF

AIRFLOW (FACE)

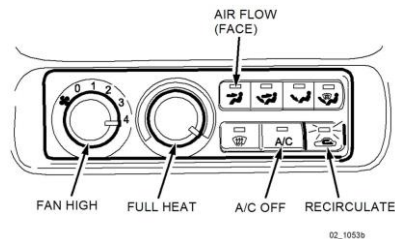

c. Open one window approximately one half inch.

d. Let the engine run for 15 minutes.

2. Remove the glove box. Refer to MGSS online instructions or Workshop Manual section 09-17.

3. Close the passenger side vent, but leave the other vents open.

4. Shake a bottle of the Mazda Air Cooling Coil Coating well and attach it to applicator, then connect the applicator to compressed shop air.

5. Insert the applicator in the grille of the recirculation door. Point the nozzle tip downwards (approximately at the 7 o'clock position) and towards the center of the cooling unit.

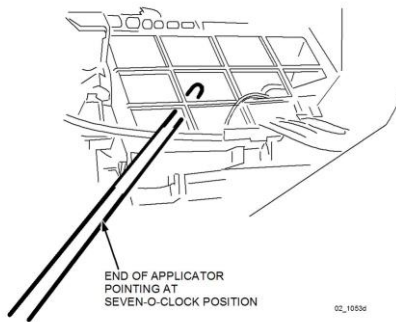

6. Spray the entire contents of the bottle in short bursts, 3 seconds ON, 3 seconds OFF into the rotating fan. A fine mist may exit from the ducts.
  7. When the bottle is empty, remove the applicator and let the fan run for 3 to 5 minutes.
- NOTE:** For reuse, clean the applicator by flushing a bottle of clean water through it.
8. Re-install the glove box.
  9. Note application date in service record.

**CONSUMER NOTICE:** The information and instructions in this bulletin are intended for use by skilled technicians. Mazda technicians utilize the proper tools/equipment and take training to correctly and safely maintain Mazda vehicles. These instructions should not be performed by "do-it-yourselfers." Customers should not assume this bulletin applies to their vehicle or that their vehicle will develop the described concern. To determine if the information applies, customers should contact their nearest authorized Mazda dealership. Mazda North American Operations reserves the right to alter the specifications and contents of this bulletin without obligation or advance notice. All rights reserved. No part of this bulletin may be reproduced in any form or by any means, electronic or mechanical---including photocopying and recording and the use of any kind of information storage and retrieval system ---without permission in writing.

**1998-2003 Protege and Protege5**

1. Dry the evaporator using the following procedure:

**WARNING:** Running the engine inside an enclosed area, such as a garage, is dangerous. Exhaust gas, which contains poisonous carbon monoxide, could easily enter the cabin. Loss of consciousness or even death could occur. Don't run the engine when inside an enclosed area.

a. Start the engine.

b. Set the HVAC controls as follows.

- RECIRCULATE
- FULL HEAT
- FAN HIGH
- A/C OFF

AIRFLOW (FACE)

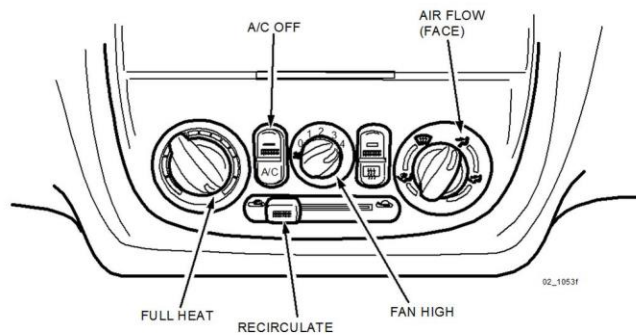

c. Open one window approximately one half inch.

d. Let the engine run for 15 minutes.

2. Remove the glove box. Refer to MGSS online instructions or Workshop Manual section 09-17.

3. Stop the engine. Switch OFF the fan motor.

4. Remove the fan resistor and inspect the evaporator for debris; remove debris using an appropriate vacuum cleaner

**WARNING:** Blower motor resistor may be extremely hot.

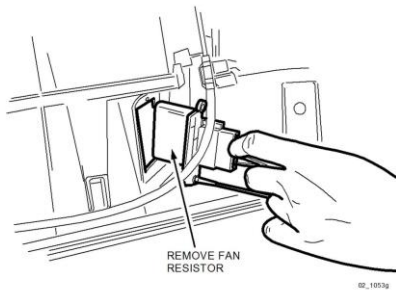

5. Reinstall the fan resistor.
6. Close the passenger side vent, but leave the other vents open.
7. Shake a bottle of the Mazda Air Cooling Coil Coating well and attach it to the applicator, then connect the applicator to compressed shop air.
8. Insert the applicator in the grille of the recirculation door. Point the nozzle tip in the direction of the evaporator.

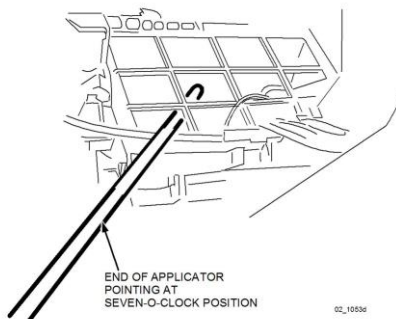

9. Switch the fan motor ON.
  10. Begin spraying by gently moving the nozzle tip in front of the evaporator surface. Spray the entire contents of the bottle in short bursts, 3 seconds ON, 3 seconds OFF onto the evaporator. A fine mist may exit from the ducts.
  11. When the bottle is empty, remove the applicator and let the fan run for 3 to 5 minutes.
- NOTE:** For reuse, clean the applicator by flushing a bottle of clean water through it.
12. Reinstall the glove box.
  13. Note application date in service record.

**CONSUMER NOTICE:** The information and instructions in this bulletin are intended for use by skilled technicians. Mazda technicians utilize the proper tools/equipment and take training to correctly and safely maintain Mazda vehicles. These instructions should not be performed by "do-it-yourselfers." Customers should not assume this bulletin applies to their vehicle or that their vehicle will develop the described concern. To determine if the information applies, customers should contact their nearest authorized Mazda dealership. Mazda North American Operations reserves the right to alter the specifications and contents of this bulletin without obligation or advance notice. All rights reserved. No part of this bulletin may be reproduced in any form or by any means, electronic or mechanical---including photocopying and recording and the use of any kind of information storage and retrieval system ---without permission in writing.

## 2000-2003 MPV Front AC

1. Dry the evaporator using the following procedure:

**WARNING:** Running the engine inside an enclosed area, such as a garage, is dangerous. Exhaust gas, which contains poisonous carbon monoxide, could easily enter the cabin. Loss of consciousness or even death could occur. Don't run the engine when inside an enclosed area.

a. Start the engine.

b. Set the HVAC controls as follows:

- RECIRCULATE
- FULL HEAT
- FRONT A/C FAN HIGH
- REAR A/C FAN HIGH

A/C OFF

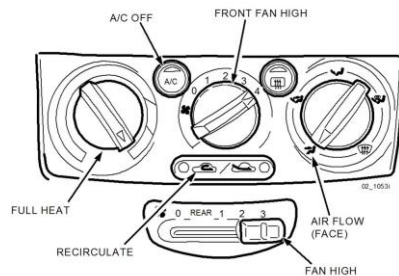

c. Open one window approximately one half inch.

d. Let the engine run for 15 minutes.

2. Remove the glove box. Refer to MGSS online instructions or Workshop Manual section 09-17.

3. Remove the dust filter cover located over the fan assembly by depressing the clip on the inner side of the cover.

4. Remove the dust filter by pulling it out of the filter housing. Discard the filter if dirty.

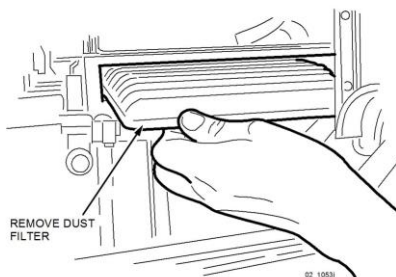

**CONSUMER NOTICE:** The information and instructions in this bulletin are intended for use by skilled technicians. Mazda technicians utilize the proper tools/equipment and take training to correctly and safely maintain Mazda vehicles. These instructions should not be performed by "do-it-yourselfers." Customers should not assume this bulletin applies to their vehicle or that their vehicle will develop the described concern. To determine if the information applies, customers should contact their nearest authorized Mazda dealership. Mazda North American Operations reserves the right to alter the specifications and contents of this bulletin without obligation or advance notice. All rights reserved. No part of this bulletin may be reproduced in any form or by any means, electronic or mechanical---including photocopying and recording and the use of any kind of information storage and retrieval system ---without permission in writing.



5. Close the passenger side vent, but leave the other vents open.
6. Shake a bottle of Mazda Air Cooling Coil Coating well and attach it to the applicator, then connect the applicator to compressed shop air.
7. Insert the applicator into the empty filter housing (approximately 4-1/4 inches from the tip of the applicator). Point the nozzle tip downwards and towards the center (approximately the 7 o'clock position).

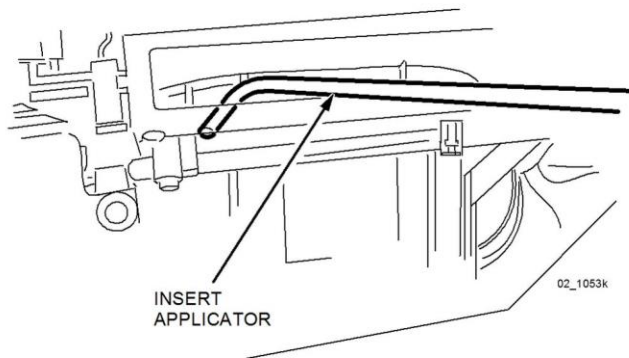

8. Spray the entire contents of the bottle in short bursts, 3 seconds ON, 3 seconds OFF into the rotating fan. A fine mist may exit from the ducts.
  9. When the bottle is empty, remove the applicator and let the fan run for 3 to 5 minutes.
- NOTE:** For reuse, clean the applicator by flushing a bottle of clean water through it.
10. Install the previously cleaned or new filter as needed and reinstall the filter cover
  11. Reinstall the glove box.

**2000-2003 MPV Rear AC (if equipped)**

12. Remove the right side cup holder.
13. Remove and disconnect the rear fan control panel and convenience tray, if equipped.
14. Be sure the HVAC controls are set per STEP 1B (see page 16).

**NOTE:** The rear fan will operate even though the rear fan control panel is disconnected.

15. Shake a new bottle of Mazda Air Cooling Coil Coating well and attach it to the applicator, then connect the applicator to compressed shop air.

16. Begin inserting the applicator through the opening of the control panel/convenience tray front to back with the tip pointed up (for space). While inserting the probe, rotate the tip outward toward the fan air intake opening. When inserted (depth of insertion is approximately half the length of the applicator), point the tip side center into the cage without touching it.

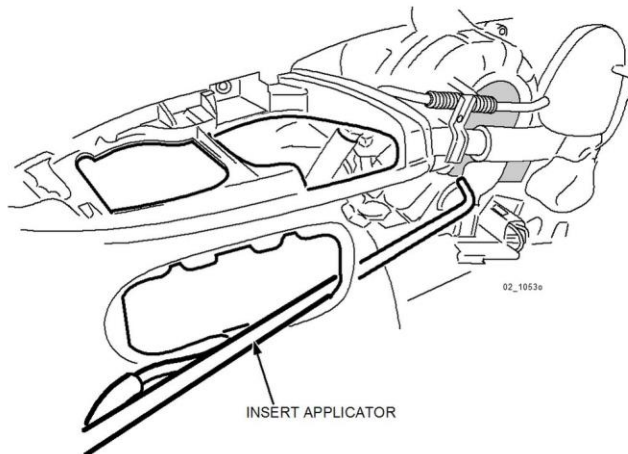

17. Spray the entire contents of the bottle in short bursts, 3 seconds ON, 3 seconds OFF into the rotating fan. A fine mist may exit from the ducts.

18. When the bottle is empty, remove the applicator and let the fan run for 3 to 5 minutes.

**NOTE:** For reuse, clean the applicator by flushing a bottle of clean water through it.

19. While the product is drying, re-install the removed parts.

20. Note application date in service record.

**CONSUMER NOTICE:** The information and instructions in this bulletin are intended for use by skilled technicians. Mazda technicians utilize the proper tools/equipment and take training to correctly and safely maintain Mazda vehicles. These instructions should not be performed by "do-it-yourselfers." Customers should not assume this bulletin applies to their vehicle or that their vehicle will develop the described concern. To determine if the information applies, customers should contact their nearest authorized Mazda dealership. Mazda North American Operations reserves the right to alter the specifications and contents of this bulletin without obligation or advance notice. All rights reserved. No part of this bulletin may be reproduced in any form or by any means, electronic or mechanical---including photocopying and recording and the use of any kind of information storage and retrieval system ---without permission in writing.

**1998 MPV Front A/C**

1. Dry the evaporator using the following procedure:

**WARNING:** Running the engine inside an enclosed area, such as a garage, is dangerous. Exhaust gas, which contains poisonous carbon monoxide, could easily enter the cabin. Loss of consciousness or even death could occur. Don't run the engine when inside an enclosed area.

a. Start the engine.

b. Set both front and rear (if applicable) HVAC controls as follows:

- RECIRCULATE
- FULL HEAT
- FAN HIGH
- A/C OFF
- AIRFLOW (FACE and FLOOR)

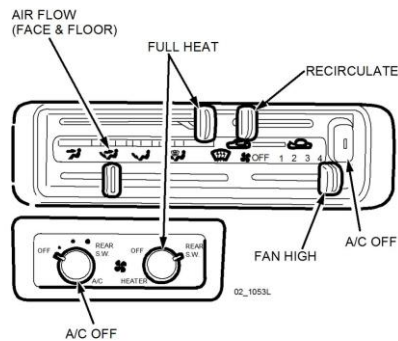

c. Open one window approximately one half inch.

d. Let the engine run for 15 minutes.

**CONSUMER NOTICE:** The information and instructions in this bulletin are intended for use by skilled technicians. Mazda technicians utilize the proper tools/equipment and take training to correctly and safely maintain Mazda vehicles. These instructions should not be performed by "do-it-yourselfers." Customers should not assume this bulletin applies to their vehicle or that their vehicle will develop the described concern. To determine if the information applies, customers should contact their nearest authorized Mazda dealership. Mazda North American Operations reserves the right to alter the specifications and contents of this bulletin without obligation or advance notice. All rights reserved. No part of this bulletin may be reproduced in any form or by any means, electronic or mechanical---including photocopying and recording and the use of any kind of information storage and retrieval system ---without permission in writing.

- Remove the glove box, removing the side fascia plate on the right door side.

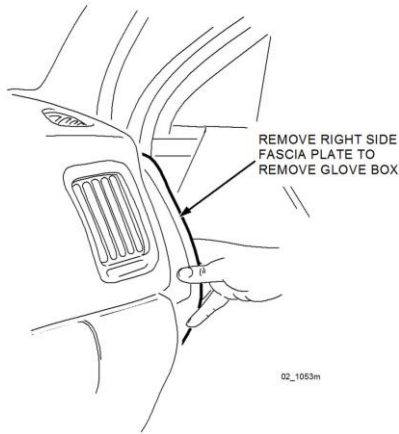

- Remove the six (6) phillips screws to remove the glove box assembly.
- Close the passenger side vent, but leave the other vents open.
- Shake a bottle of Mazda Air Cooling Coil Coating well and attach it to the applicator, then connect the applicator to compressed shop air.
- Insert the applicator into the grille of the re-circulate door. Point the nozzle tip down and towards the center of the cooling unit (approximately 7 o'clock position).

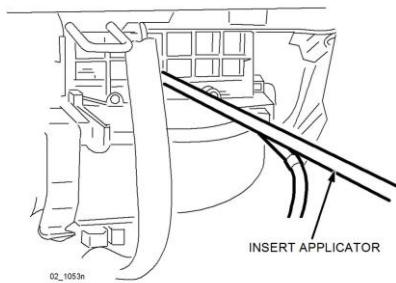

- Spray the entire contents of the bottle in short bursts, 3 seconds ON, 3 seconds OFF into the rotating fan. A fine mist may exit from the ducts.
- When the bottle is empty, remove the applicator and let the fan run for 3 to 5 minutes.

**NOTE:** For reuse, clean the applicator by flushing a bottle of clean water through it.

**CONSUMER NOTICE:** The information and instructions in this bulletin are intended for use by skilled technicians. Mazda technicians utilize the proper tools/equipment and take training to correctly and safely maintain Mazda vehicles. These instructions should not be performed by "do-it-yourselfers." Customers should not assume this bulletin applies to their vehicle or that their vehicle will develop the described concern. To determine if the information applies, customers should contact their nearest authorized Mazda dealership. Mazda North American Operations reserves the right to alter the specifications and contents of this bulletin without obligation or advance notice. All rights reserved. No part of this bulletin may be reproduced in any form or by any means, electronic or mechanical---including photocopying and recording and the use of any kind of information storage and retrieval system ---without permission in writing.

**1998 MPV Rear A/C (if equipped)**

9. Remove the four (4) screws holding down the tailgate sill, then remove the sill.
  10. Remove the one (1) screw holding down the left inner panel, then lift the complete panel out of the clips.
  11. Be sure the HVAC controls are set per STEP 1B.
  12. Shake a new bottle of Mazda Air Cooling Coil Coating well and attach it to the applicator, then connect the applicator to compressed shop air.
  13. Position the applicator with the nozzle tip pointing down into the air intake of the fan motor.
  14. Spray the entire contents of the bottle in short bursts, 3 seconds ON, 3 seconds OFF into the rotating fan. A fine mist may exit from the ducts.
  15. When the bottle is empty, remove the applicator and let the fan run for 3 to 5 minutes.
- NOTE:** For reuse, clean the applicator by flushing a bottle of clean water through it.
16. While the product is drying, re-install removed parts.
  17. Note application date in service record.

**CONSUMER NOTICE:** The information and instructions in this bulletin are intended for use by skilled technicians. Mazda technicians utilize the proper tools/equipment and take training to correctly and safely maintain Mazda vehicles. These instructions should not be performed by "do-it-yourselfers." Customers should not assume this bulletin applies to their vehicle or that their vehicle will develop the described concern. To determine if the information applies, customers should contact their nearest authorized Mazda dealership. Mazda North American Operations reserves the right to alter the specifications and contents of this bulletin without obligation or advance notice. All rights reserved. No part of this bulletin may be reproduced in any form or by any means, electronic or mechanical---including photocopying and recording and the use of any kind of information storage and retrieval system ---without permission in writing.

**2001-2002 Millenia (with cabin air filter)**

1. Dry the evaporator using the following procedure:

**WARNING:** Running the engine inside an enclosed area, such as a garage, is dangerous. Exhaust gas, which contains poisonous carbon monoxide, could easily enter the cabin. Loss of consciousness or even death could occur. Don't run the engine when inside an enclosed area.

a. Start the engine.

b. Set the HVAC controls as follows:

- RECIRCULATE
- FULL HEAT (display indicates 90°F)
- FAN HIGH
- A/C OFF ( )

AIRFLOW (FACE)

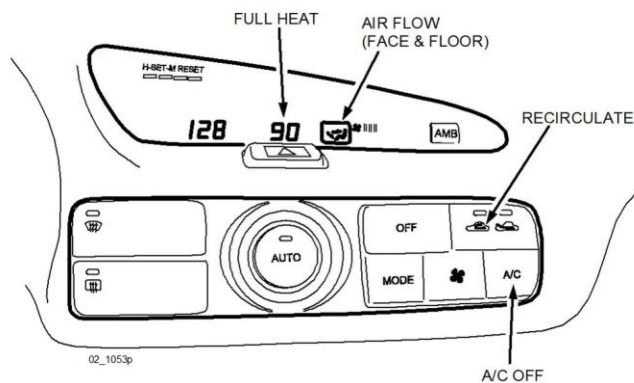

**NOTE:** There are three A/C positions on the LCD panel (A/C, A/C econ, ). Depress the A/C button until is selected.

c. Open one window approximately one half inch.

d. Let the engine run for 15 minutes.

**CONSUMER NOTICE:** The information and instructions in this bulletin are intended for use by skilled technicians. Mazda technicians utilize the proper tools/equipment and take training to correctly and safely maintain Mazda vehicles. These instructions should not be performed by "do-it-yourselfers." Customers should not assume this bulletin applies to their vehicle or that their vehicle will develop the described concern. To determine if the information applies, customers should contact their nearest authorized Mazda dealership. Mazda North American Operations reserves the right to alter the specifications and contents of this bulletin without obligation or advance notice. All rights reserved. No part of this bulletin may be reproduced in any form or by any means, electronic or mechanical---including photocopying and recording and the use of any kind of information storage and retrieval system ---without permission in writing.

2. Remove the lower panel by pulling downward at both ends.

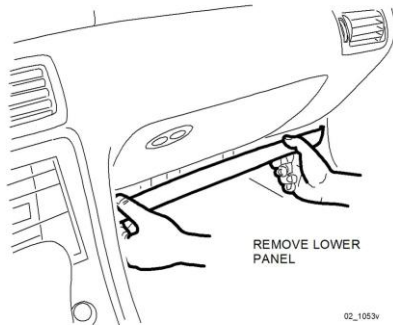

3. Remove the 10 mm nut retaining the cabin air filter bracket.

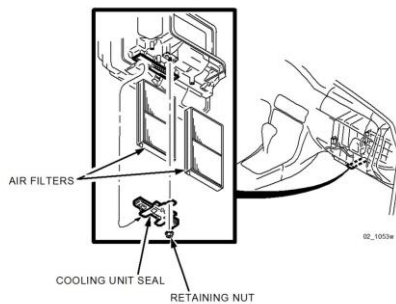

4. Remove the bracket by sliding downward.
5. Remove the cabin air filters by sliding downward. Discard the filters if dirty.
6. Cover the cabin air filter access hole with duct tape.
7. Pierce a hole in the center of the duct tape with a knife.
8. Close the passenger side vent, but leave the other vents open.
9. Shake a bottle of Mazda Cooling Coil Coating well and attach it to applicator, then connect the applicator to compressed shop air.

**CONSUMER NOTICE:** The information and instructions in this bulletin are intended for use by skilled technicians. Mazda technicians utilize the proper tools/equipment and take training to correctly and safely maintain Mazda vehicles. These instructions should not be performed by "do-it-yourselfers." Customers should not assume this bulletin applies to their vehicle or that their vehicle will develop the described concern. To determine if the information applies, customers should contact their nearest authorized Mazda dealership. Mazda North American Operations reserves the right to alter the specifications and contents of this bulletin without obligation or advance notice. All rights reserved. No part of this bulletin may be reproduced in any form or by any means, electronic or mechanical---including photocopying and recording and the use of any kind of information storage and retrieval system ---without permission in writing.

10. Insert the applicator into the pierced hole through the duct tape.

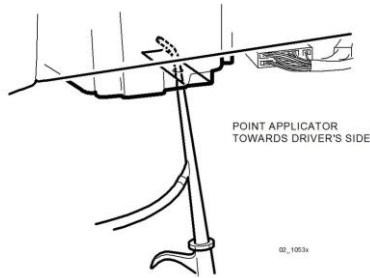

11. Point the nozzle tip in the direction of the driver's side.
  12. Spray the entire contents of the bottle in short bursts, 3 seconds ON, 3 seconds OFF into the rotating fan. A fine mist may exit from the ducts.
  13. When the bottle is empty, remove the applicator and let the fan run for 3 to 5 minutes.
- NOTE:** For reuse, clean the applicator by flushing a bottle of clean water through it.
14. Remove the duct tape and install the previously cleaned or new filters as needed.
  15. Reinstall the cabin air filter bracket.
  16. Reinstall the lower panel.
  17. Note application date in service record.



**1998-2000 Millenia**

1. Dry the evaporator using the following procedure:

**WARNING:** Running the engine inside an enclosed area, such as a garage, is dangerous. Exhaust gas, which contains poisonous carbon monoxide, could easily enter the cabin. Loss of consciousness or even death could occur. Don't run the engine when inside an enclosed area.

a. Start the engine.

b. Set the HVAC controls as follows:

- RECIRCULATE
- FULL HEAT (display indicates 90°F)
- FAN HIGH
- A/C OFF ( )
- AIRFLOW (FACE)

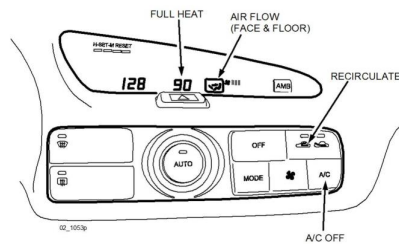

**NOTE:** There are three A/C positions on the LCD panel (A/C, A/C econ, ). Depress the A/C button until is selected.

c. Open one window approximately one half inch.

d. Let the engine run for 15 minutes.

2. Remove the glove box by removing the two (2) screws on the bottom of the glove box assembly.

3. Close the passenger side vent, but leave the other vents open.

4. Shake a bottle of Mazda Cooling Coil Coating well and attach it to the applicator, then connect the applicator to compressed shop air.

**CONSUMER NOTICE:** The information and instructions in this bulletin are intended for use by skilled technicians. Mazda technicians utilize the proper tools/equipment and take training to correctly and safely maintain Mazda vehicles. These instructions should not be performed by "do-it-yourselfers." Customers should not assume this bulletin applies to their vehicle or that their vehicle will develop the described concern. To determine if the information applies, customers should contact their nearest authorized Mazda dealership. Mazda North American Operations reserves the right to alter the specifications and contents of this bulletin without obligation or advance notice. All rights reserved. No part of this bulletin may be reproduced in any form or by any means, electronic or mechanical---including photocopying and recording and the use of any kind of information storage and retrieval system ---without permission in writing.

5. Insert the applicator through the right side the glove box guide into the grille of the recirculation door. Point the nozzle tip downwards and towards the center (approximately 7 o'clock position).

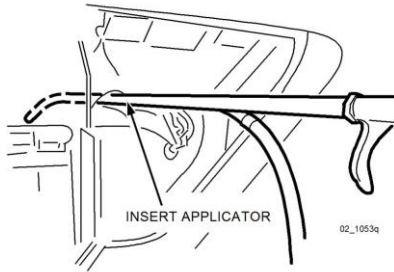

6. Spray the entire contents of the bottle in short bursts, 3 seconds ON, 3 seconds OFF into the rotating fan. A fine mist may exit from the ducts.
  7. When the bottle is empty, remove the applicator and let the fan run for 3 to 5 minutes.
- NOTE:** For reuse, clean the applicator by flushing a bottle of clean water through it.
8. While the product is drying, re-install the glove box.
  9. Note application date in service record.

**CONSUMER NOTICE:** The information and instructions in this bulletin are intended for use by skilled technicians. Mazda technicians utilize the proper tools/equipment and take training to correctly and safely maintain Mazda vehicles. These instructions should not be performed by "do-it-yourselfers." Customers should not assume this bulletin applies to their vehicle or that their vehicle will develop the described concern. To determine if the information applies, customers should contact their nearest authorized Mazda dealership. Mazda North American Operations reserves the right to alter the specifications and contents of this bulletin without obligation or advance notice. All rights reserved. No part of this bulletin may be reproduced in any form or by any means, electronic or mechanical---including photocopying and recording and the use of any kind of information storage and retrieval system ---without permission in writing.

**1999-2005 Miata**

1. Dry the evaporator using the following procedure:

**WARNING:** Running the engine inside an enclosed area, such as a garage, is dangerous. Exhaust gas, which contains poisonous carbon monoxide, could easily enter the cabin. Loss of consciousness or even death could occur. Don't run the engine when inside an enclosed area.

a. Start the engine.

b. Set the HVAC controls as follows:

- Air source: re-circulate
- Heater control: full heat
- Fan: high
- A/C switch: off
- Airflow (Face)

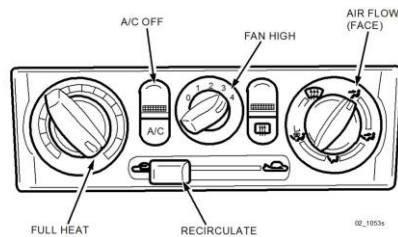

c. Open one window approximately one half inch.

d. Let the engine run for 15 minutes.

2. Open the glove box and remove by lifting the left side and pulling the right side in a downward direction.

3. Close the passenger side vent, but leave the other vents open.

4. Shake a bottle of Mazda Cooling Coil Coating well and attach it to the applicator, then connect the applicator to compressed shop air.

**CONSUMER NOTICE:** The information and instructions in this bulletin are intended for use by skilled technicians. Mazda technicians utilize the proper tools/equipment and take training to correctly and safely maintain Mazda vehicles. These instructions should not be performed by "do-it-yourselfers." Customers should not assume this bulletin applies to their vehicle or that their vehicle will develop the described concern. To determine if the information applies, customers should contact their nearest authorized Mazda dealership. Mazda North American Operations reserves the right to alter the specifications and contents of this bulletin without obligation or advance notice. All rights reserved. No part of this bulletin may be reproduced in any form or by any means, electronic or mechanical---including photocopying and recording and the use of any kind of information storage and retrieval system ---without permission in writing.

5. Insert the applicator in the grille of the the recirculation door. Point the nozzle tip downwards and towards center (approximately the 7 o'clock position).

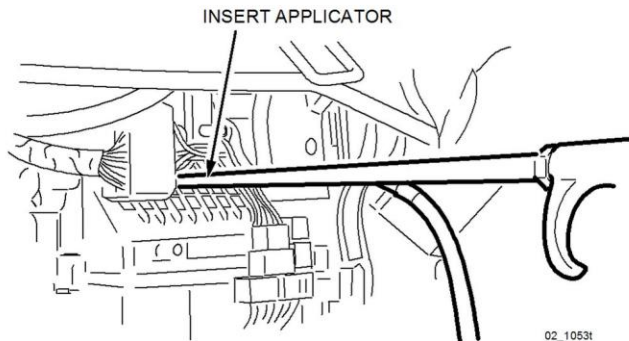

6. Spray the entire contents of the bottle in short bursts, 3 seconds ON, 3 seconds OFF into the rotating fan. A fine mist may exit from the ducts.
  7. When the bottle is empty, remove the applicator and let the fan run for 3 to 5 minutes.
- NOTE:** Clean the empty bottle by flushing it with clean water.
8. While the product is drying, re-install the glove box.
  9. Note application date in service record.

**CONSUMER NOTICE:** The information and instructions in this bulletin are intended for use by skilled technicians. Mazda technicians utilize the proper tools/equipment and take training to correctly and safely maintain Mazda vehicles. These instructions should not be performed by "do-it-yourselfers." Customers should not assume this bulletin applies to their vehicle or that their vehicle will develop the described concern. To determine if the information applies, customers should contact their nearest authorized Mazda dealership. Mazda North American Operations reserves the right to alter the specifications and contents of this bulletin without obligation or advance notice. All rights reserved. No part of this bulletin may be reproduced in any form or by any means, electronic or mechanical---including photocopying and recording and the use of any kind of information storage and retrieval system ---without permission in writing.

## PARTS INFORMATION

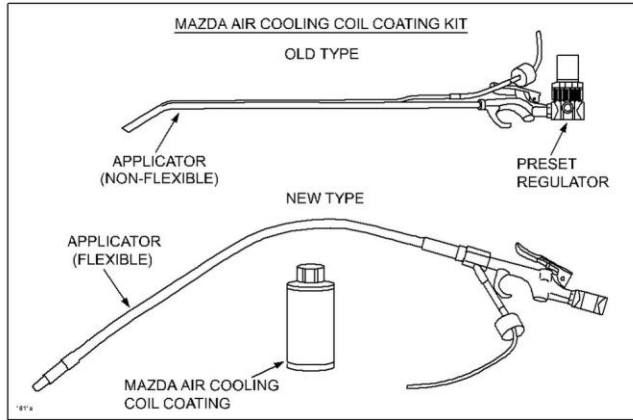

Part Number	Description	Qty.	Notes
0000-77-570K-01	Mazda Air Cooling Coil Coating Kit	1	Includes applicator, UltiFlex flexible applicator tool, and 4-bottles of Mazda Air Cooling Coil Coating 118 ml (4 fl oz)
0000-77-550E-01	Mazda Air Cooling Coil Coating	1= (4 bottles)	Replacement bottles 118 ml (4 fl oz), requires one-bottle per vehicle (two-bottles required for MPV with rear air)

## WARRANTY INFORMATION

This repair is not covered by warranty.

**CONSUMER NOTICE:** The information and instructions in this bulletin are intended for use by skilled technicians. Mazda technicians utilize the proper tools/equipment and take training to correctly and safely maintain Mazda vehicles. These instructions should not be performed by "do-it-yourselfers." Customers should not assume this bulletin applies to their vehicle or that their vehicle will develop the described concern. To determine if the information applies, customers should contact their nearest authorized Mazda dealership. Mazda North American Operations reserves the right to alter the specifications and contents of this bulletin without obligation or advance notice. All rights reserved. No part of this bulletin may be reproduced in any form or by any means, electronic or mechanical---including photocopying and recording and the use of any kind of information storage and retrieval system ---without permission in writing.