

DOMETIC HEATING FURNACES

EN Furnace Limit Switch Service Bulletin

USA & Canada

Service Office
Dometic Corporation
1120 North Main Street
Elkhart, IN 46514

Service Center & Dealer Locations

Visit:
www.dometic.com

Read these instructions carefully.

Model	Serial Number Range
All Small & Medium Furnaces (AFS, AFM, DFS, DFM)	73985322 – 81099541

We have been able to identify a non-safety related nuisance issue that is occurring on our Dometic/Atwood furnaces. This nuisance issue has the potential to occur on all models of Dometic/Atwood Furnace with serial numbers between 73985322 and 81099541. The nuisance issue enunciates by either blowing the protective fuse, opening the circuit breaker in the furnace circuit, or rendering the furnace inoperative. Our testing has shown that in ALL instances the furnace fails in a safe manner.

The cause of this nuisance issue is a mistaken omission of a plastic wire tie to suspend the heat exchanger limit switch wires up and away from the exhaust tube vent terminal. The omission of this component allows the limit switch wires to potentially melt on the vent terminal, shorting to ground, and causing either the fuse or circuit breaker in the circuit to blow, or the sail switch to become inoperative. **In ALL cases the safety devices in the system are performing as designed and prevent the furnace from operating.**

Dometic recognizes this nuisance tripping issue is an inconvenience to our OE and potential end-use customers and we apologize for the extra work that may result. In an effort to try and reduce the amount of work required to correct this mistake we have designed and tested a field repair for this occurrence which will be more expensive for Dometic but will make the field repair much easier. The repair will consist of sliding a 6" long, high-temperature rated, fiberglass sleeve over the exhaust tube after removal of the vent assembly. The field repair kit will be available within March, 2018. The field repair kit part # is 31389, Flat Rate Time is .5 and the fault code is 617.25.

1 SLEEVING THE EXHAUST TUBE

1.1 Removing the vent assembly

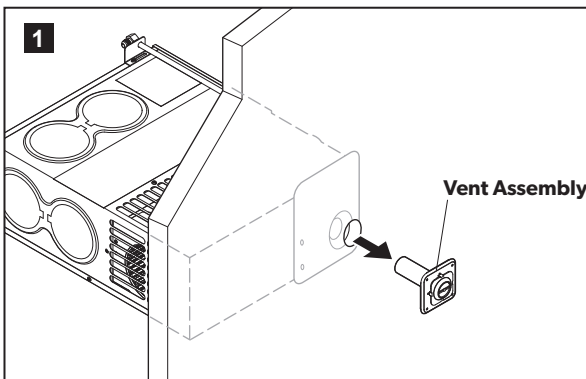

1.2 Installing the fiberglass sleeve

