



SI M01 02 18  
Warranties

February 2018  
Technical Service

## N18 THERMOSTAT WITH THERMOSTAT HOUSING: LIMITED WARRANTY EXTENSION TO 10 YEARS/120,000 MILES

### MODEL

R55 (Cooper S Clubman) (N18 Engine) Model Year 2014 produced from 6/28/2013 to 6/27/2014	R55 (Cooper S Clubman JCW) (N18 Engine) Model Year 2014 produced from 6/29/2013 to 6/21/2014	R57 (Cooper S Convertible) (N18 Engine) Model Year 2014 produced from 6/28/13 to 7/1/2014	R57 (JCW Convertible) (N18 Engine) Model Year 2014 produced from 7/3/2013 to 6/30/2014
R58 (Cooper S Coupe) (N18 Engine) Model Year 2014 produced from 6/28/2013 to 7/1/2014	R58 (JCW Coupe) (N18 Engine) Model Year 2014 produced from 6/28/2013 to 7/2/2014	R58 (JCW Coupe) (N18 Engine) Model Year 2014 produced from 6/28/2013 to 7/2/2014	R59 (Cooper S Roadster) (N18 Engine) Model Year 2014 produced from 6/28/2013 to 7/3/2014
R59 (JCW Roadster) (N18 Engine) Model Year 2014 produced from 7/2/2013 to 6/11/2014	R60 (Cooper S Countryman) (N18 Engine) Model Year 2014 produced from 6/28/2013 to 6/28/2014	R60 (Cooper S Countryman ALL4) (N18 Engine) Model Year 2014 produced from 6/19/2013 to 6/27/2014	R60 (JCW Countryman) (N18 Engine) Model Year 2014 produced from 7/5/2013 to 6/28/2014
R61 (Cooper S Paceman) (N18 Engine) Model Year 2014 produced from 6/29/2013 to 6/28/2014	R61 (Cooper S Paceman ALL4) (N18 Engine) Model Year 2014 produced from 6/18/2013 to 6/10/2014	R61 (JCW Paceman ) (N18 Engine) Model Year 2014 produced from 7/5/2013 to 6/27/2014	



**Note:** The “Model” information above is for informational purposes only, it is not the only deciding

factor.

To determination vehicle eligibility and to confirm this “conditional” coverage applies, always perform a VIN-specific DCSnet Warranty Inquiry first; please refer to the “Eligible Vehicles” section of this bulletin for further details.

### INFORMATION

For the above-referenced vehicles, MINI USA, a division of BMW of North America, LLC (“MINI USA”) is extending the limited warranty for the engine coolant system’s **thermostat with thermostat housing** to:

- 10 years/120,000 miles as determined by the vehicle’s original in-service date

--	--

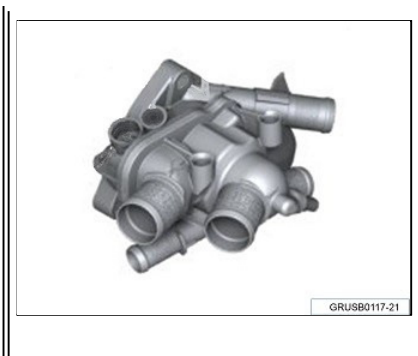

- This “component-specific” limited warranty extension applies to defects in materials or workmanship.
- This coverage is subject to the same vehicle eligibility requirements, limitations, and exclusions that apply to the New Passenger Car Limited Warranty.

**This bulletin is notice of a “limited warranty extension.” This is NOT a notice of a Recall or Service Action**

There is no immediate repair required unless the MINI vehicle is currently experiencing this problem.

### **Customer Notification Letter**

Even though this is **NOT** a Recall, MINI USA sent VIN-specific customer notification letters in a phased release.

## **ELIGIBLE VEHICLES**

To assist you in identifying those vehicles that have this “component-specific” extended limited warranty coverage, the DCSnet Warranty Vehicle Inquiry has been updated with the VIN and Component-specific “Vehicle Comment” or flag shown below:

**For this vehicle, the engine coolant system’s thermostat with thermostat housing limited warranty for defects in materials or workmanship has been extended to 10 year/120,000 mile as determined from the original in-service date. This coverage is subject to the same vehicle eligibility requirements, limitations, and exclusions that apply to the MINI New Passenger Car Limited Warranty, Please see SI M01 02 18 (DC 11 53 90 12 00).**

**Note:** Before performing a repair and submitting a claim under this extended coverage, first confirm that the vehicle has the above “Notice of Limited Warranty Extension” in the DCSnet Warranty Inquiry “Vehicle Comments” section.

If the vehicle has the above flag, the vehicle was determined to be eligible and included by meeting all of the applicable criteria, for example:

- **Series;**
- **Model;**
- **Model Year;**
- **Engine type;**
- **Production date (strictly by the mm/dd/yyyy format).**

Based on applying all of the above criteria, if you have ELW eligibility and/or coverage questions, please contact the Warranty department through IDS by selecting “Coverage, Policy and Coding” **prior** to performing any repairs.

## **PARTS INFORMATION**



**Note: Please refer to the Electronic Parts Catalog (ETK/EPC), using the customer's VIN to**

**locate the applicable replacement part numbers.**

- Only order these **parts in the quantities needed** to address customers' vehicles that have confirmed failures.
- **“Only in conjunction with” parts:** When applicable, if ETK/EPC item identifies additional part(s) that must also be replaced/installed “in-conjunction” with performing a covered repair, these “required” additional items are also covered under the terms of this extended limited warranty.
- Also refer to ETK/EPC and the repair instructions for onetime-use fasteners/screws and other information regarding repair-related gaskets, seals, fluid and/or lubricants that also need to be replaced/used and claimed.

#### **Bulk Materials**

<b>Part Number</b>	<b>Description</b>	<b>Quantity</b>
82 14 0 031 133	Antifreeze (One Gallon)	See below

## **WARRANTY INFORMATION**

The engine coolant system's thermostat with thermostat housing limited warranty extension to 10 years/120,000 miles applies to “eligible US-specification MINI vehicles” that are registered, operated and have their covered repair performed by an authorized MINI dealer in the United States (including Puerto Rico).

**The existing limited warranty coverage for the whole vehicle and other components has not changed.**

This coverage supersedes the coverage that is provided under the MINI NEXT Certified Pre-Owned Program or any BMW Group Vehicle Service Contract that applies to the vehicle.

Should the thermostat with thermostat housing fail again, this component is covered by the remaining portion of the extended limited warranty coverage period.

#### **Non-Qualifying Repairs**

Non-US specification vehicles, ineligible vehicles, eligible vehicles operated and repaired outside the United States and Puerto Rico and/or the diagnosis and repair of other unrelated issues are not covered under the terms of this limited warranty extension.

#### **Qualifying Repairs - Claim Submission**

Claim this work with the defect code and labor operations provided below.

<b>Defect Code:</b>	<b>1153901200</b>	<b>R5x, R6x N18 US version of characteristic map thermostat</b>
---------------------	-------------------	---

#### **Component Replacement related to an Illuminated Malfunction Light and/or Stored Fault(s)**

<b>Labor Operation:</b>	<b>Labor Allowance:</b>	<b>Description:</b>
00 00 006	Refer to KSD2	Performing “vehicle test” (with vehicle diagnosis system – checking faults) (Main work)

Or:		
00 00 556	Refer to KSD2	Performing “vehicle test” (with vehicle diagnosis system – checking faults) (Plus work)
And:		
61 21 528	Refer to KSD2	Connect an approved battery charger/power supply (indicated in KSD2 as “Charging battery”)
And, as necessary:		
61 00 006	Work time (WT)	Performing vehicle diagnosis – test module
And:		
00 65 560	Refer to KSD2	Replacing coolant thermostat

Work time labor operation code 61 00 006 is not considered a Main labor operation; however, it does require an individual punch time and an explanation on the repair order and in the claim comments section.

Or, for a:

**Component Replacement not related to a Malfunction Light and/or Stored Fault(s)**

<b>Labor Operation:</b>	<b>Labor Allowance:</b>	<b>Description:</b>
17 00 009	Refer to KSD2	Checking cooling system for leaks (Main work)
Or		
17 00 509	Refer to KSD2	Checking cooling system for leaks (Plus work)
And:		
00 65 560	Refer to KSD2	Replacing coolant thermostat

Refer to KSD2 for the corresponding flat rate unit (FRU) allowances.

And, for both, as needed:

**Sublet – Bulk Materials**

Sublet Code 4	See sublet reimbursement calculation below	Reimbursement for the repair-related bulk material (MINI part number, please do not use the part number for claim submission)
---------------	--	---

MINI Antifreeze/Coolant for the amount needed to replace what was drained with a “50/50 coolant/water solution” at dealer net plus your dealer’s handling (Bulk container reference P/N 82 14 0 031 133).

Enter this material costs in sublet and itemize the amounts on the repair order and in the claim comment section.

**Previous Customer-pay Repairs – Limited Warranty Extension Reimbursement**

Under this extended limited warranty, MINI USA, a division of BMW of North America, LLC (“MINI USA”) will provide reimbursement for “qualifying customer-pay repairs” that were performed on an eligible vehicle **prior** to

the release of this component-specific limited warranty extension.

Customer-pay repairs are subject to the same vehicle eligibility requirements, limitations, and exclusions that apply to the MINI New Passenger Car Limited Warranty.

### **Repairs that do not Qualify for Reimbursement**

Repairs performed on ineligible vehicles, eligible vehicles operated and repaired outside the United States and Puerto Rico and/or the diagnosis and repair of other unrelated issues. This exclusion also applies to repairs that were performed using (including those repairs that result from using) non-genuine MINI parts and/or used MINI passenger car parts.

### **Requesting Reimbursement for a Previous Repair that Qualifies**

For a customer to request reimbursement for a “qualifying customer-pay repair” performed either by an authorized MINI dealer or independent repair shop located in the United States (including Puerto Rico), please have him/her submit his/her reimbursement request “online” at [www.MINI-RP.com](http://www.MINI-RP.com) under the following reference:

- **M-ELWR 2018 Thermostat Housing with Thermostat 10Y120M**

### **Reimbursement Request Procedure**

The online process is initiated by attaching/sending “PDF files” of the supporting documentation for the “prior repair.”

The website attached sample customer letter provides information as to “what” documentation is needed to be supplied to support a prior repair.

The letter also includes alternative methods to request reimbursement, either through the mail or by fax as described below:

MINI Customer Reimbursement Center

Attention: M-ELWR 2018 Thermostat Housing with Thermostat 10Y120M

P.O. Box 561089

Dallas, Texas 75356

Fax number: 877-457-0214

Please allow 4-6 weeks for processing your request

Should you have any questions concerning this reimbursement process, please call 1-844-203-1331.

### **MINI Owner/Operator Inquiries and Assistance**

For all other questions, please contact the MINI USA Motorer Relations and Services via email at [MINI.assistance@askMINIUSA.com](mailto:MINI.assistance@askMINIUSA.com) or via telephone at 1-866-ASK-MINI (275-6464).

## **ATTACHMENTS**

View PDF attachment [M010218\\_Thermostat Sample Customer Letter](#).

[ Copyright ©2018 BMW of North America, Inc. ]



4-777-H406A-0000001-001-000-000-000

JANE SMITH  
123 ANY STREET  
PAPERTOWN, NJ 12345-6789

January 2018

This **“Important Limited Warranty Information”** applies to the MINI vehicle with the Vehicle Identification Number (VIN) of **AAAAAAAAAAAAAAAAAA**.

Dear MINI Motorer:

MINI USA is committed to delivering the ultimate in product satisfaction to our Motorers

Towards that end, MINI is extending the limited warranty for the engine's:

- **Thermostat housing with thermostat**

On the above-referenced vehicle to:

- **10 years/120,000 miles, whichever occurs first, as determined by your vehicle’s original in-service date**

This “component-specific” limited warranty extension applies to defects in materials and workmanship and is subject to the applicable vehicle and coverage eligibility requirements, exclusions and limitations that apply to the MINI New Passenger Limited Warranty.

**This is notice of a “limited warranty extension.” This is not a notice of a Recall or Service Action.**

If a repair to this component is required, please contact your nearest authorized MINI dealer in the United States or Puerto Rico to schedule an appointment. Your authorized MINI dealer will determine the vehicle’s eligibility and review the scope of repair covered by this component-specific limited warranty extension.

After vehicle inspection and diagnosis, eligible repair work will be performed by the authorized MINI dealer in the United States (including Puerto Rico) free of charge.

Repairs performed on ineligible vehicles, eligible vehicles operated and repaired outside the United States and Puerto Rico and/or the diagnosis and repair of other “unrelated” issues are not covered under the terms of this limited warranty extension.

The integrity of our products is essential to MINI’s success and our Motorers’ trust. We are determined to exceed your expectations and hope this warranty extension further enhances your motoring experiences.

Sincerely,

MINI USA, a division of BMW of North America, LLC

**Company**

BMW of North America,  
LLC

BMW Group Company

**Mailing Address**

PO Box 1227  
Westwood, NJ  
07675-1227

**Telephone**

(800) 831-1117

**E-mail**

Customerrelations@  
bmwusa.com

**Website**

bmwusa.com

777-3002-0714

## Previous Motorer-Pay Repair Reimbursement - Limited Warranty Extension

### MINI USA, a division BMW of North America, LLC

January 2018

#### VIN AAAAAAAAAAAAAAAAAA

Under this extended limited warranty, MINI USA, a division of BMW of North America, LLC will provide reimbursement for “qualifying Motorer -pay repairs” on eligible MINI vehicles that were performed prior to the release of this Motorer notification.

If you previously paid for a repair that you believe would now be covered under this limited warranty extension, please submit your reimbursement request online at [www.MINI-RP.com](http://www.MINI-RP.com).

Motorer -pay repairs are subject to the applicable vehicle and coverage eligibility requirements, exclusions and limitations that apply to the MINI New Passenger Limited Warranty

#### Requesting Reimbursement for a Previous Repair that Qualifies

Repairs performed on ineligible vehicles or the diagnosis and repair of other unrelated issues, do not qualify for reimbursement.

To initiate the online process, you will be asked to attach PDF files of the required documentation as outlined in the reimbursement checklist on the next page.

Alternatively, you may mail or fax your request and documentation to:

MINI Customer Reimbursement Center  
Attention: M-ELWR 2018 Thermostat Housing with Thermostat 10Y120M  
P.O. Box 561089  
Dallas, Texas 75356

Fax number: 877-457-0214

Please allow 4-6 weeks for processing your request.

Should you have any questions concerning this reimbursement process, please call 1-844-203-1331.

For all other questions, please contact the MINI USA Motorer Relations and Services via email at [MINI.assistance@askMINIUSA.com](mailto:MINI.assistance@askMINIUSA.com) or via telephone at 1-866-ASK-MINI (275-6464).

Please have your 17-character Vehicle Identification Number (VIN) available and include the VIN with all communications.

#### Repairs that do not Qualify for Reimbursement

Repairs performed on ineligible vehicles, eligible vehicles operated and repaired outside the United States and Puerto Rico and/or the diagnosis and repair of other “unrelated” issues are not covered under the terms of this limited warranty extension.

**Previous Motorer-Pay Repair Reimbursement – Documentation Checklist****MINI USA, a division of BMW of North America, LLC**

Reimbursement is available to the MINI Motorer who incurred the expense.

When submitting a reimbursement for a previous repair, please provide **legible copies** of the following documentation and include your VIN, name, address and your preferred contact telephone number(s):

**Repair Order (RO) or Invoice**

This document should include the following information:

- Motorer name and address
- Vehicle Identification Number (“VIN”)
- The date of repair
- The mileage when the repair was performed
- Itemized breakdown of the labor charges for all repairs\* including diagnosis
- Itemized breakdown of the parts, including any miscellaneous items, billed for all repairs\*

\*For repair orders containing multiple repair line items, only the specific line item expenses that relate to the component that is covered by this extended limited warranty will be considered for reimbursement.

**Proof of Payment**

Please provide a copy of at least **one** of the following items as valid proof of payment:

- Repair order (RO)/invoice stamped and dated as “PAID”
- Copy of a cancelled check
- Copy of a signed credit/debit card receipt
- Copy of a credit/debit card statement

**Determining if an eligible vehicle’s repair qualifies for reimbursement:**

Please use the following questions to review your repair order documentation prior to submitting a reimbursement request:

1. Why was the vehicle brought into the repair facility?
2. What was the repair facility's diagnosis?
3. What did the repair facility do to correct the concern and does it qualify?