



SI B01 10 14  
Warranties

February 2018  
Warranties

## ENGINE CAMSHAFT (VANOS) ADJUSTMENT UNITS: LIMITED WARRANTY EXTENSION TO 10 YEARS WITHOUT MILEAGE LIMITATION

New information provided by this revision is preceded by this symbol .

This Service Information bulletin supersedes SI B01 10 14 dated February 2018.

### What's New:

- The Eligible Vehicle statements have been updated.
- The coverage period statement in the Warranty Information section has been corrected.

### MODEL

E60 (528i and 528i xDrive Sedans) (N52K Engine) Model Year 2010 produced 9/3/2009 to 12/17/2009	E70 (X5 3.0si) (N52K Engine) Model Year 2010 produced 10/1/2009 to 3/18/2010	E82 (128i Coupe) (N51 Engine) Model Years 2010, 2011 and 2012 produced 9/3/2009 to 8/16/2011	E82 (128i Coupe) (N52K Engine) Model Years 2010, 2011 and 2012 produced 9/30/2009 to 8/10/2011
E83 (X3 3.0si) (N52K Engine) Model Year 2010 produced 9/3/2009 to 8/20/2010	E88 (128i Convertible) (N51 Engine) Model Years 2010, 2011 and 2012 produced 9/4/2009 to 8/16/2011	E88 (128i Convertible) (N52K Engine) Model Years 2010, 2011 and 2012 produced 9/30/2009 to 8/9/2011	E89 (Z4 sDrive30i Roadster) (N52K Engine) Model Years 2010 and 2011 produced 9/30/2009 to 8/9/2011
E90 (328i and 328i xDrive Sedans) (N51 Engine) Model Years 2010 and 2011 produced 10/1/2009 to 12/1/2011	E90 (328i and 328i xDrive Sedans) (N52K Engine) Model Years 2010 and 2011 produced 9/4/2009 to 12/6/2011	E91 (328i and 328i xDrive Sport Wagons) (N52K Engine) Model Years 2010 and 2011 produced 10/1/2009 to 8/4/2011	E92 (328i and 328i xDrive Coupe) (N51 Engine) Model Years 2010 and 2011 produced 9/29/2009 to 8/4/2011
E92 (328i and 328i xDrive Coupe) (N54K Engine) Model Years 2010 and 2011 produced 9/2/2009 to 8/5/2011	E92 (328i and 328i xDrive Coupe) (N55 Engine) Model Year 2011 produced 2/26/2010 to 8/3/2011	E93 (328i Convertible) (N51 Engine) Model Year 2011 produced 10/1/2009 to 3/18/2010	E93 (328i Convertible) (N51 Engine) Model Years 2010 and 2011 produced 9/4/2009 to 8/1/2011
F10 (528i Sedan) (N52T Engine) Model Year 2011 produced 12/9/2009 to 8/31/2011	F25 (X3 xDrive28i) (N52T Engine) Model Year 2011 produced 3/16/2010 to 9/16/2011		



**Note:** The “Model” information above is for informational purposes only, it is not the only deciding factor.

Further, for the E82 and E88 Models, full model year 2012 production is **not** included in this action.

To determine vehicle eligibility and that this coverage applies, always perform a VIN-specific DCSnet Warranty Inquiry first; please refer to the “Eligible Vehicles” section of this bulletin for further details.

## INFORMATION

BMW of North America, LLC (“BMW NA”) is extending the limited warranty for the Camshaft (VANOS) Adjustment Units on certain model BMW vehicles equipped with the non-turbocharged 6-cylinder engine to:

- **10 years without mileage limitation, as determined by the vehicle’s original in-service date.**

This “component-specific” limited warranty extension applies to defects in materials or workmanship.

This coverage is subject to the same vehicle eligibility requirements, limitations, and exclusions that apply to the BMW New Vehicle Limited Warranty for Passenger Cars and Light Trucks.

**This bulletin is notice of a “limited warranty extension.” This is NOT a notice of a Recall or Service Action.**

There is no immediate repair required unless the BMW vehicle is currently experiencing this problem. For additional troubleshooting and repair-related information, please refer to SI [B12 14 12](#).

This extended limited warranty coverage **does not** apply to the vehicles affected by following Recall Campaign:

SI B11 07 14	Recall Campaign 14V- 176: N51, N52K and N52T Engine – Replace VANOS Gear Bolts
SI B11 08 14	Recall Campaign 14V- 176: N55 Engine – Replace VANOS Gear Bolts

### Customer Notification Letter

Even though this is **NOT** a Recall, BMW NA had sent VIN-specific customer notification letters beginning the week of September 08, 2014 in a staggered release. A sample letter is attached.



## ELIGIBLE VEHICLES

To assist you in identifying those vehicles that have this “component-specific” extended limited warranty coverage, the DCSnet Warranty Vehicle Inquiry has been updated with the VIN and Component-specific “Vehicle Comment” shown below:

**BMW NA has extended the limited warranty for the engine’s intake and exhaust Camshaft (VANOS) Adjustment Units on this vehicle to 10 years without mileage limitation as determined from the original in-service date. Please see SI B01 10 14.**

Note: Before performing a repair and submitting a claim under this extended coverage, first confirm that the vehicle has the above “Notice of Limited Warranty Extension” in the DCSnet Warranty Inquiry “Vehicle Comments” section.

If the vehicle has the above flag, the vehicle was determined to be eligible and included by meeting all of the applicable criteria, for example:

- **Series;**
- **Models;**
- **Model Years;**
- **Engine types;**
- **Production date (strictly by the mm/dd/yyyy format).**

Based on applying all of the above criteria, if you have ELW eligibility and/or coverage question, please contact the Warranty department through IDS by selecting "Coverage, Policy and Coding" prior to performing any repairs.

## PROCEDURE

When applicable, please follow the VANOS bolt replacement procedure outlined in the attachment; it contains the modified repair instructions.

**The bolt replacement procedure must be performed when the vehicle's engine is at room temperature.**

**Performing the torque sequence described in the attachment when the engine is hot will result in inaccurate torque values.**

The ISTA/D repair instructions apply only to the VANOS gear assembly replacement.

## PARTS INFORMATION

The part number listed below is only for those vehicles that need a VANOS adjustment unit assembly replaced on one side and a set of VANOS adjustment bolts replaced on the other side (intake or exhaust).

Part Number	Description	Quantity
11 36 8 602 263	VANOS Bolt (ISA screw M7x21)	4*

\*Per Bolt Repair Procedure Step 8 or 15: Additional replacement bolt(s) may be needed if they do not torque to the correct specification. Claim the additional bolt(s), if necessary, and explain the reason in the claim comments.

Please refer to the Electronic Parts Catalog (EPC/ETK) for the complete VANOS unit assembly (intake or exhaust), using the customer's VIN to locate the replacement part number(s).

**Note: Only order the necessary parts, in the quantities needed, for customers' vehicles that have confirmed failures.**

Also, refer to ETK and the repair instructions for onetime-use fasteners and component information regarding additional and/or replacement screws, gaskets and seals that need to be installed and claimed.

## WARRANTY INFORMATION

**UPDATE !** The engine's intake and exhaust Camshaft (VANOS) Adjustment Unit component-specific limited warranty extension of 10 years without mileage limitation applies to "eligible US-specification BMW vehicles" that are registered, operated and have their covered repair performed by an authorized BMW center in the United States (including Puerto Rico).

**The existing limited warranty coverage for the whole vehicle and other components has not changed.**

This coverage supersedes the coverage that is provided under the BMW Certified Pre-Owned Program or any BMW Group Vehicle Service Contract that applies to the vehicle.

Should the exhaust Camshaft (VANOS) Adjustment Unit fail again, these component are covered by the remaining portion of the extended limited warranty coverage period.

### Non-Qualifying Repairs

Non-US specification vehicles, ineligible vehicles, eligible vehicles operated and repaired outside the United States and Puerto Rico and/or the diagnosis and repair of other unrelated issues are not covered under the terms of this limited warranty extension.

### Qualifying Repairs - Claim Submission

Claim this work with the defect code and labor operations provided below.

<b>Defect Code:</b>	<b>1136900400</b>	<b>E82 E88 E9x E60 E70 E83 E84 E89 F10 F25 N51 N52 VANOS adjuster</b>
---------------------	-------------------	---

### Replacing one VANOS unit assembly on one side and a set of VANOS bolts on the other side

<b>Labor Operation:</b>	<b>Labor Allowance:</b>	<b>Description:</b>
00 62 175	Refer to KSD2	Vehicle test (includes connecting an approved battery charger/power supply), replace a VANOS adjustment unit <b>on one side</b> ; replace the bolted connection on an adjustment unit <b>on the other side</b> (Main work)
Or:		
00 62 772	Refer to KSD2	Vehicle test (includes connecting an approved battery charger/power supply), replace a VANOS adjustment unit on one side; replace the bolted connection on an adjustment unit on the other side (Plus work)

If you are using a Main labor code for another repair, use the Plus code labor operation 00 62 772 instead of 00 62 175.

Or:

<b>Labor Operation:</b>	<b>Labor Allowance:</b>	<b>Description:</b>
00 62 176	Refer to KSD2	Vehicle test (includes connecting an approved battery charger/power supply), replace a VANOS adjustment unit <b>on one side</b> ; replace the bolted connection on an adjustment unit <b>on the other side</b> and removing and installing the engine oil pan to remove fragments (Main work)
Or:		
00 62 773	Refer to KSD2	Vehicle test (includes connecting an approved battery charger/power supply), replace a VANOS adjustment unit <b>on one side</b> ; replace the bolted connection on an adjustment unit

		<b>on the other side</b> and removing and installing the engine oil pan to remove fragments (Plus work)
--	--	---

If you are using a Main labor code for another repair, use the Plus code labor operation 00 62 773 instead of 00 62 176.

Note: Please refer to the attachment "B011014\_VANOS Bolt Repair Procedure" for the related repair information for the items above.

Or:

#### Replacing both VANOS unit assemblies

Labor Operation:	Labor Allowance:	Description:
00 62 142	Refer to KSD2	Vehicle test (includes connecting an approved battery charger/power supply) and <b>replacing both VANOS adjustment units</b> (Main work)
Or:		
00 62 653	Refer to KSD2	Vehicle test (includes connecting an approved battery charger/power supply) and <b>replacing both VANOS adjustment units</b> (Plus work)

If you are using a Main labor code for another repair, use the Plus code labor operation 00 62 653 instead of 00 62 142.

Or:

Labor Operation:	Labor Allowance:	Description:
00 62 143	Refer to KSD2	Vehicle test (includes connecting an approved battery charger/power supply), replacing both VANOS adjustment units and removing and installing the engine oil pan to remove fragments (Main work)
Or:		
00 62 654	Refer to KSD2	Vehicle test (includes connecting an approved battery charger/power supply), replacing both VANOS adjustment units and removing and installing the engine oil pan to remove fragments (Plus work)

If you are using a Main labor code for another repair, use the Plus code labor operation 00 62 654 instead of 00 62 143.

Refer to KSD2/AIR for the corresponding flat rate unit (FRU) allowances.

And, if applicable:

 **Consequential Additional Repair(s)**

When additional work and/or parts are required as a “direct result” of issue being address in this Service Information bulletin, claim these items under the defect code listed above together the corresponding labor operations listed in the KSD2.

Please explain reason for this repair work (the why and what) on the repair order in the claim comments section.

And, as necessary:

#### **Sublet – Bulk Materials**

<b>Sublet Code 4</b>	See the sublet reimbursement calculations below	Reimbursement for the repair-related bulk materials (Do not use part numbers for claim submission)
----------------------	---	--

Sublet reimbursement calculation for claiming repair-related bulk materials (BMW part numbers) is at the dealer net price for the “quantities used” plus your center’s handling.

Enter this material cost in sublet and itemize the amount on the repair order and in claim comment section.

#### **Overlapping Labor Procedure – Other Repairs**

If invoicing the KSD2 flat rate labor operation codes for other repair work results in overlapping labor, for those flat rate labor operations that are affected, you can now:

- Replace the stated KSD2 “FRU allowance” with a “reduced FRU value” to eliminate the overlapping labor.

For help in identifying the overlapping labor, please refer to the AIR FRU Plausibility Check (Overlapping Labor Tool) that is located in the AIR Client.

Eligible other repair work being claimed under a different defect code will require separate punch times.

On the repair order and in the claim comment section, please identify and itemize those labor operations being claimed with a “reduced FRU value.”

#### **Previous Customer-pay Repairs – Limited Warranty Extension Reimbursement**

As provided and outlined in the “Customer Notification” letter, under this extended limited warranty, BMW of North America, LLC will provide reimbursement for “qualifying customer-pay repairs” that were performed on an eligible vehicle prior to the release of the customer notification.

Customer pay repairs, when they were performed, are subject to the applicable New Vehicle/SAV Limited Warranty’s exclusions and limitations, in addition to the vehicle and coverage eligibility requirements.

Repairs, those performed on ineligible vehicles or the diagnosis and repair of other unrelated issues, do not qualify for reimbursement.

For a customer to request reimbursement for a “qualifying customer-pay repair” performed either by an authorized BMW center or independent repair shop, please have him/her submit his/her reimbursement request online at [www.BMW-RP.com](http://www.BMW-RP.com).

This website provides information regarding the required supporting documentation and alternative methods to submit a reimbursement request.

Posted: Tuesday, February 20, 2017

## **ATTACHMENTS**

View PDF attachment [B011014 VANOS Bolt Repair Procedure](#).

View PDF attachment [B011014 VANOS Sample Customer letter.](#)

[ Copyright ©2018 BMW of North America, Inc. ]

Changes to this revision are identified by a black bar.

**VANOS UNIT "BOLTS" REPLACEMENT PROCEDURE (ONE SIDE ONLY)**

This portion of the procedure applies to those vehicles which are found to have "one VANOS unit" that does not have any broken and/or loose bolt(s).

This modified repair procedure is reflected in the labor operation time allowances that apply to the following labor operations:

**00 62 175 (Main)/00 62 772 (Plus)**

Perform a vehicle test (includes connecting an approved battery charger/power supply), replace a VANOS adjustment unit **on one side**; replace the bolted connection on an adjustment unit **on the other side**

Or:

**00 62 176 (Main)/00 62 773 (Plus)**

Perform a vehicle test (includes connecting an approved battery charger/power supply), replace a VANOS adjustment unit **on one side**; replace the bolted connection on an adjustment unit **on the other side** and removing and installing the engine oil pan to remove fragments.

**IMPORTANT**

**The bolt replacement procedure must be performed when the vehicle's engine is at room temperature.**

**Performing the torque sequence described in the attachment when the engine is hot will result in inaccurate torque values.**

**VANOS UNIT ASSEMBLY REPLACEMENT (ONE OR BOTH)**

The ISTA/D repair instructions are for a VANOS gear assembly replacement. This applies to the other VANOS unit which has broken and/or loose bolt(s).

**REPLACING BOTH VANOS UNITS ASSEMBLIES**

**00 62 142 (Main)/00 62 653 (Plus)**

Perform a vehicle test (includes connecting an approved battery charger/power supply) and replacing both VANOS adjustment units.

**00 62 143 (Main)/00 62 654 (Plus)**

Perform a vehicle test (includes connecting an approved battery charger/power supply), replacing both VANOS adjustment units and removing and installing the engine oil pan to remove fragments.



Required Special Tools

 <p>A long, thin metal socket with a hexagonal base and a threaded end. The part number '83 30 2 333 891' is engraved on the side. A small white label with the text 'GRUSB1114-53' is located at the bottom right of the image.</p>	<p>Socket for Torque Wrench</p> <p>P/N 83 30 2 333 891</p> <p>Distributed via Automatic Tool Shipment. Refer to SI B04 08 14.</p>
 <p>A digital torque wrench with a black handle and a silver head. The head has a circular dial and a hook at the end. A small white label with the text 'GRUSB1114-54' is located at the bottom right of the image.</p>	<p>Torque Wrench</p> <p>P/N 81 64 0 418 185</p> <p>Distributed via Automatic Tool Shipment. Refer to SI B04 08 14.</p>

**Torque Wrench Set Up:**

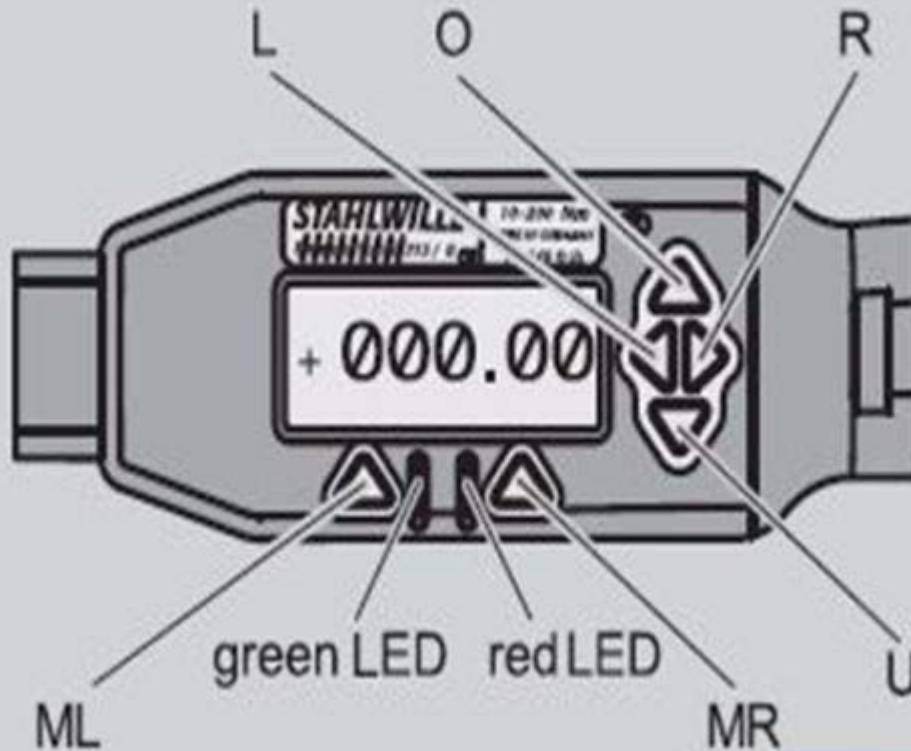

GRUSB1114-55

**Initial setup of torque wrench must be completed when using the tool for the first time.**

Push any of the green buttons to turn on.

Press the "ML" button to select language. Scroll up and down with the "O" and "U" buttons to select English.

Press the "MR" button to select.

Press the "ML" button to enter the menu. Select "OK" and scroll using the "O" and "U" buttons to select "presets." Select the "MR" button to select "modify."

Scroll down using the "U" button to "shutdown time." Select the "MR" button to select "modify." Increase the time by using the "O" button. Press repeatedly until "9" is displayed. Select the "MR" button to "save" the setting. This setting will now automatically turn off the tool after 9 minutes of inactivity, and it will be saved for the next usage.

Select "return" twice with the "ML" button to go back to the main screen.

Select "menu" with the "ML" button.

Ignore "Password." Do not enter a password.

Select "OK" with the "MR" button.

Scroll with the "O" and "U" buttons to "presets" and select "modify" with the "MR" button.

Scroll with the “O” and “U” buttons to “unit” and select “modify” with the “MR” button.

Scroll with the “O” and “U” buttons to “Nm” and select “OK” with the “MR” button.

Scroll with the “O” and “U” buttons to “adaptor length” and select “modify” with the “MR” button.

Scroll with the “O” and “U” buttons and the “L and R” buttons to enter the digits. Enter 17.50 mm and select “OK” with the “MR” button. This setting identifies the length of the tool, i.e., ratchet head or crow’s foot wrench end.

Select “return” twice with the “ML” button to go back to the main screen.

If the batteries are replaced, the initial setup will need to be performed again.

**Selecting and Entering Rotation Angle Mode:**

Press the “L” and “R” buttons at the same time. The “preload” screen should now be displayed. Preload is the initial torque setting.

Scroll with the “O” and “U” buttons and the “L and R” buttons to enter the digits. Enter 6.00 (6 Nm initial torque) and select “OK” with the “MR” button. The angle torque screen will be displayed automatically when this is complete.

Scroll with the “O” and “U” buttons and the “L and R” buttons to enter the digits. Enter 60.00 (60 degree angle torque) and select “OK” with the “MR” button. The screen will now state it is the “direct” mode.

Press the “tare” to zero the measurement. The torque wrench is now ready for use.

These values will stay stored as long as the tool is powered up. If the tool turns off after 9 minutes of inactivity, the initial torque and angle torque will be erased and will not be available for the next usage. The values will need to be reentered if the torque wrench turns off.



Alternative removal and installation tools can be sourced locally via SNAP-ON Tools™.

Torque Wrench, Electronic, TechAngle®

P/N ATECH1FR240B



GRUSB1114-63

 <p style="text-align: center; font-size: small;">GRUS81114-64</p>	<p>T45 TORX Socket (Long) P/N BLPTL3845TP</p>
 <p style="text-align: center; font-size: small;">GRUS81114-65</p>	<p>Adaptor, 1/4" Internal drive x 3/8" External drive P/N TA3 (1/4" to 3/8")</p>
<p><b>Preliminary Work:</b></p>	
<p>1. Remove the cylinder head cover per Repair Instruction 11 12 000, "Removing and installing or sealing cylinder head cover."</p>	
<p>2. Remove the fan and fan cowl per Repair Instruction 17 11 035, "Removing and installing/replacing fan cowl with electric fan."</p>	
<p><b>IMPORTANT: Do not reuse aluminum bolts. Once the aluminum bolts are removed, they must be replaced with new bolts.</b></p>	

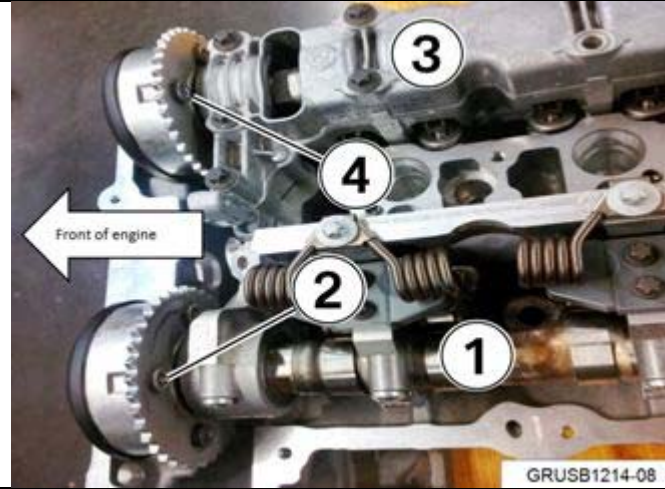

Overview of the Components:

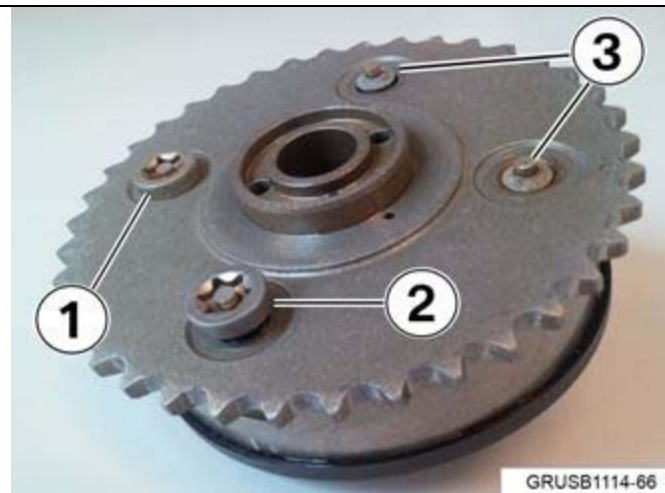

- Intake camshaft (1)
- Intake VANOS gear assembly bolts (2)
- Exhaust camshaft (3)
- Exhaust VANOS gear assembly bolts (4)



3. Evaluation of bolt:
- If any of the bolts were loose or broken during this procedure, the VANOS assembly will need to be replaced. Refer to step 14.
  - VANOS bolt is tight (1)
  - VANOS bolt is loose (2)
  - VANOS bolt heads have sheared off (3)
- Note: VANOS gear assembly removed from engine for clarity. Do not remove VANOS Gear Assembly

Intake VANOS Adjustment Unit:	
 <p>GRUSB1114-56</p>	<p>4. Replace and torque the aluminum bolts (1-4) one at a time.</p> <p>Note: 1-4 is not a sequence; they can be replaced in any sequence.</p> <p><b>IMPORTANT: Never loosen more than one VANOS assembly bolt (1-4) at a time to avoid losing the sealing and alignment of gear assembly.</b></p>
 <p>GRUSB1114-57</p>	<p>5. Turn the engine by hand, using a suitable tool on the crankshaft central bolt to align one of the bolts (1), as shown in the illustration.</p> <p>Remove the bolt (1) using the required special tool (2).</p>
 <p>GRUSB1114-58</p>	<p>6. Clean the threads on the VANOS assembly using compressed air to remove the excess oil. The torque wrench results will be more consistent when cleaning the threads for more than 3 seconds.</p> <p><b>Always wear safety glasses.</b></p>

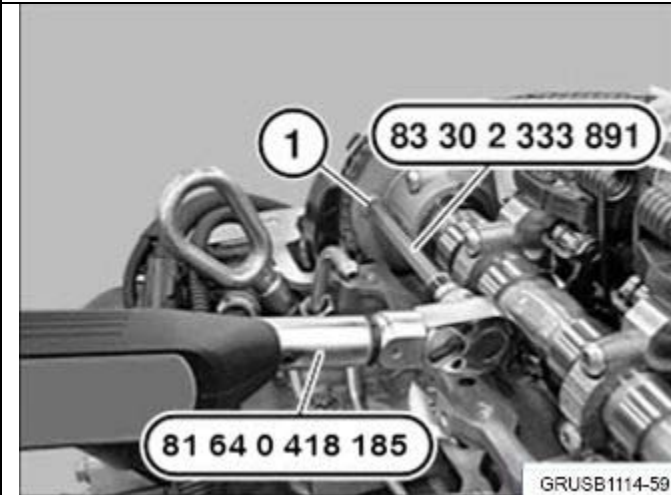

**7. IMPORTANT: The bolts require initial torque and angle torque. Observe the procedures in this step and the next step very carefully!**

**Move the torque wrench slowly and smoothly during the initial torque and angle torque steps. Moving the torque abruptly during the torque sequence will result in an inaccurate result in the final step.**

Install one new P/N 11 36 8 602 263 aluminum VANOS bolt and apply the initial torque, using the required special tools to the specification below.

**Initial torque: 6 Nm**

Turn the torque wrench very slowly and do not over-torque the bolt. The handle of the torque wrench will vibrate and the green LED will briefly blink when the 6 Nm have been reached.

**Angle torque: 60°**

The torque wrench will automatically switch to angle torque and show zero degrees. Begin turning the torque wrench. The red and green LEDs will blink on the tool, warning the technician that the desired value is approaching. When 60 degrees has been reached, the handle will vibrate and the green LED will illuminate. The screen may or may not record the angle torque. Do not be alarmed if the screen freezes and captures a value that is a few degrees lower than the desired value.

**Do not rotate the torque wrench any further after the handle vibrates and both LEDs illuminate.**



8. While performing the angle torque, the digital screen on the torque wrench will display the current Nm meter value. This value should be between **8 Nm-14 Nm**.

If the displayed value is not within the specification, the bolt will need to be removed and replaced with a new bolt again. Repeat as necessary.

To reset the torque wrench and clear the screen to Nm again, just press the "MR" button to continue replacing additional bolts.



9. **If any of the bolts were loose or broken during this procedure, the VANOS assembly will need to be replaced. Refer to step 17.**

If no bolts were found loose, repeat steps 4-8 for the remaining 3 bolts on the VANOS gear assembly. It is good practice to mark each bolt head with a felt marker as it is replaced, so one is not mistaken and removed again.

Or:

Perform Step 10: Exhaust VANOS Adjustment Unit

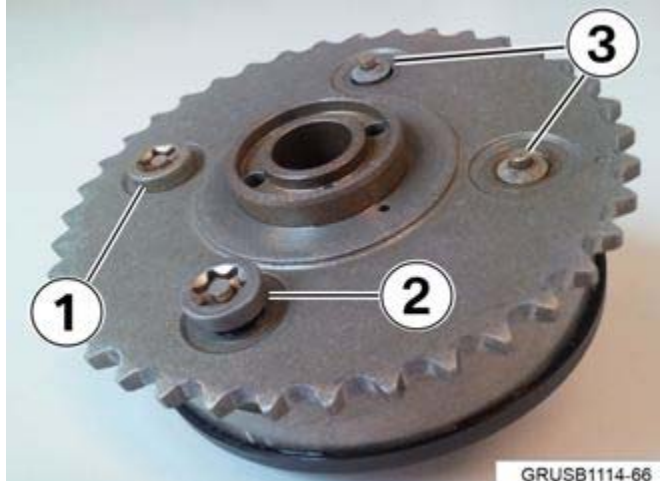

Exhaust VANOS Adjustment Unit:	
 <p>GRUSB1114-66</p>	<p>10. Evaluation of bolt:</p> <p>If any of the bolts were loose or broken during this procedure, the VANOS assembly will need to be replaced. Refer to step 16.</p> <p>VANOS bolt is tight (1)</p> <p>VANOS bolt is loose (2)</p> <p>VANOS bolt heads have sheared off (3)</p> <p>Note: VANOS gear assembly removed from engine for clarity. Do not remove VANOS Gear Assembly</p>
 <p>GRUSB1114-56</p>	<p>11. Replace and torque the aluminum bolts (1-4) one at a time.</p> <p><b>IMPORTANT: Never loosen more than one VANOS assembly bolt (1-4) at a time to avoid losing the sealing and alignment of gear assembly.</b></p>
 <p>GRUSB1114-61</p>	<p>12. Turn the engine by hand using a suitable wrench on the crankshaft central bolt to align the bolt (1) as shown in the illustration.</p> <p>Remove the bolt (1) using the required special tool.</p> <p>Note: The tool will be on a slight angle when loosening.</p>



13. Clean the threads on the VANOS assembly using compressed air to remove the excess oil. The torque wrench results will be more consistent when cleaning the threads for more than 3 seconds.

**Always wear safety glasses.**

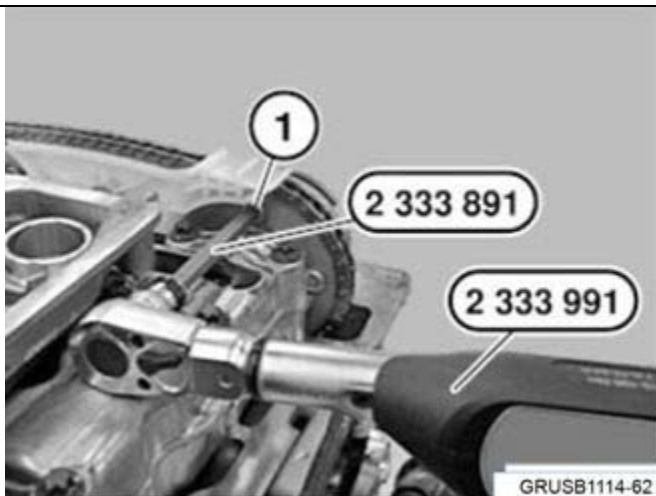

14. **IMPORTANT: The bolts require initial torque and angle torque. Observe the procedures in this step and the next step very carefully!**

**Move the torque wrench slowly and smoothly during the initial torque and angle torque steps. Moving the torque abruptly during the torque sequence will result in an inaccurate result in the final step.**

Install one new P/N 11 36 8 602 263 aluminum VANOS bolt and apply the initial torque, using the required special tools to the specification below.

**Initial torque: 6 Nm**

Turn the torque wrench very slowly and do not over-torque the bolt. The handle of the torque wrench will vibrate and the green LED will briefly blink when the 6 Nm have been reached.

**Angle torque: 60°**

The torque wrench will automatically switch to angle torque and show zero degrees. Begin turning the torque wrench. The red and green LEDs will blink on the tool, warning the technician that the desired value is approaching. When 60 degrees has been reached, the handle will vibrate and the green LED will illuminate. The screen may or may not record the angle torque. Do not be alarmed if the screen freezes and captures a value that is a few degrees lower than the desired value.

	<p><b>Do not rotate the torque wrench any further after the handle vibrates and both of the LEDs illuminate.</b></p> <p>Note: The tool will be on a slight angle when tightening.</p>
	<p>15. While performing the angle torque, the digital screen on the torque wrench will display the current Nm meter value. This value should be between <b>8 Nm-14 Nm</b>.</p> <p>If the displayed value is not within the specification, the bolt will need to be removed and replaced with a new bolt again. Repeat as necessary.</p> <p>To reset the torque wrench and clear the screen to Nm again, just press the “MR” button to continue replacing additional bolts.</p>
<p><b>16. If any of the bolts were found loose or broken during this procedure, the affected VANOS assembly will need to be replaced. Refer to step 17.</b></p> <p>If no bolts were found loose, repeat steps 10-15 for the remaining 3 bolts on the applicable VANOS gear assembly. It is good practice to mark each bolt head with a felt marker as it is replaced, so one is not mistaken and removed again. Refer to step 18 when complete.</p>	
<p>17. If any of the VANOS bolts were found loose or broken, that VANOS unit will need to be replaced. Refer to Repair Instruction 11 36 046, “Removing and installing or replacing intake and exhaust camshaft adjusters.”</p>	
<p>18. Reassemble the vehicle per the applicable repair instructions.</p>	



1-111-TJNUM\_1234567-111-2-333-444-555-666

Customer Name 1  
Customer Name 2  
Address 1  
Address 2  
City State ZIP



August 2014

This **“Important Limited Warranty Information”** applies to the BMW vehicle with the Vehicle Identification Number (VIN) of **WBANB535X01234567**.

Dear BMW Owner/Lessee:

BMW is committed to delivering the ultimate in product satisfaction to our customers.

Towards that end, BMW is extending the limited warranty for the **engine’s intake and exhaust Camshaft (VANOS) Adjustment Units** on the above-referenced vehicle to:

**10 years without mileage limitation, as determined by your vehicle’s original in-service date.**

This “component-specific” limited warranty extension applies to defects in materials and workmanship and is transferable to any subsequent purchaser of your BMW vehicle.

**This is notice of a “limited warranty extension” only. This is not a notice of a Recall or Service Action.**

If a repair is required during the extended limited warranty coverage period, eligible work performed by an authorized BMW center in the United States (including Puerto Rico) will be completed free of charge.

In the event your vehicle’s Check Engine/Service Engine Soon warning light is illuminated along with other warning messages, please contact your nearest authorized BMW center in the U.S or Puerto Rico to schedule an appointment for inspection, diagnosis and repair.

Your authorized BMW center will review the scope of repair covered by the limited warranty extension. Diagnosing and repairing other unrelated issues is not covered under this warranty extension.

The integrity of our products is essential to BMW’s success and our customers’ trust. We are determined to exceed your expectations and hope this warranty extension further enhances your ownership experience.

Sincerely,

BMW of North America, LLC

**Company**

BMW of North America, LLC

BMW Group Company

**Mailing Address**

PO Box 1227  
Westwood, NJ  
07675-1227

**Telephone**

(800) 831-1117

**E-mail**

Customerrelations@  
bmwusa.com

**Website**

bmwusa.com

## Previous Customer-pay Repair Reimbursement – Limited Warranty Extension

### BMW of North America, LLC



August 2014

#### **VIN WBANB535X01234567**

Under this extended limited warranty, BMW of North America, LLC will provide reimbursement for eligible customer-pay repairs performed prior to the release of this customer notification.

If you previously paid for a repair that you believe would now be covered under this limited warranty extension, please submit your reimbursement request online at [www.BMW-RP.com](http://www.BMW-RP.com).

To initiate the online process, you will be asked to attach PDF files of the required documentation as outlined in the reimbursement checklist on the next page.

Alternatively, you may mail or fax your request and documentation to:

BMW Customer Reimbursement Center  
Attention: B-ELWR 2014 VANOS Units  
P.O. Box 561089  
Dallas, TX 75356

Fax number: 877-434-2992

Please allow 4-6 weeks for processing your request.

Should you have any questions concerning this reimbursement process, please call 1-844-857-0341.

For all other questions, please contact BMW's Customer Relations and Services via email at [Customerrelations@bmwusa.com](mailto:Customerrelations@bmwusa.com) or via telephone at 1-800-831-1117.

Please have your 17-character Vehicle Identification Number (VIN) available and include the VIN with all communications.

## Previous Customer-pay Repair Reimbursement – Documentation Checklist

### BMW of North America, LLC



Reimbursement is available to the BMW Owner/Lessee who incurred the expense.

When submitting a reimbursement for a previous repair, please provide **legible copies** of the following documentation and include your VIN, name, address and your preferred contact telephone number(s):

#### Repair Order (RO) or Invoice

This document should include the following information:

- Customer name and address
- Vehicle Identification Number (“VIN”)
- The date of repair
- The mileage when the repair was performed
- Itemized breakdown of the labor charges for all repairs\* including diagnosis
- Itemized breakdown of the parts, including any miscellaneous items, billed for all repairs\*

\*For repair orders containing multiple repair line items, only the specific line item expenses that relate to the component that is covered by this extended limited warranty will be considered for reimbursement.

#### Proof of Payment

Please provide a copy of at least **one** of the following items as valid proof of payment:

- Repair order (RO)/invoice stamped and dated as “PAID”
- Copy of a cancelled check
- Copy of a signed credit/debit card receipt
- Copy of a credit/debit card statement

#### Determining a repair’s eligibility for reimbursement:

Please use the following questions to review your repair order documentation prior to submitting a reimbursement request:

1. Why was the vehicle brought into the repair facility?
2. What was the repair facility's diagnosis?
3. What did the repair facility do to correct the concern?