

# Technical Service Bulletin

Mazda North American Operations  
Irvine, CA 92618-2922



<b>Subject:</b> <b>ENGINE MISFIRE DURING ACCELERATION WITH CHECK ENGINE LIGHT FLASHING AND DTCs P0302:00, P0303:00 AND/OR U0401:00</b>	<b>Bulletin No.:</b> 01-010/18
	<b>Last Issued:</b> 03/29/2018

## APPLICABLE MODEL(S)/VINS

2016-2017 CX-9 vehicles with VINs lower than JM3TC\*\*\*\*\*135222 (produced before Dec. 27, 2016)

## DESCRIPTION

Some vehicles may exhibit an engine misfire during acceleration with the check engine light flashing and the following DTC(s).

- P0302:00 - Cylinder No.2 misfire detected and/or
- P0303:00 - Cylinder No.3 misfire detected

**NOTE:** Even if a misfire occurred, the DTCs may not be stored because they are set after the continuous misfire occurred for 2 drive cycles. In this case, check if the following information is available to verify if the vehicle is applicable to this Service Information.

- The customer states that the misfire occurred and at the same time the check engine light started flashing.
- DTC U0401:00 ((ABS) Signal error from PCM) is detected.

**CONSUMER NOTICE:** The information and instructions in this bulletin are intended for use by skilled technicians. Mazda technicians utilize the proper tools/equipment and take training to correctly and safely maintain Mazda vehicles. These instructions should not be performed by "do-it-yourselfers." Customers should not assume this bulletin applies to their vehicle or that their vehicle will develop the described concern. To determine if the information applies, customers should contact their nearest authorized Mazda dealership. Mazda North American Operations reserves the right to alter the specifications and contents of this bulletin without obligation or advance notice. All rights reserved. No part of this bulletin may be reproduced in any form or by any means, electronic or mechanical---including photocopying and recording and the use of any kind of information storage and retrieval system ---without permission in writing.

This concern may be caused if the exhaust manifold variable valve shaft (1) is out of alignment and/or the exhaust manifold variable valve housing (2) is out of shape. The exhaust manifold variable valve (3) then interferes with the housing and becomes stuck closed when the engine is hot.

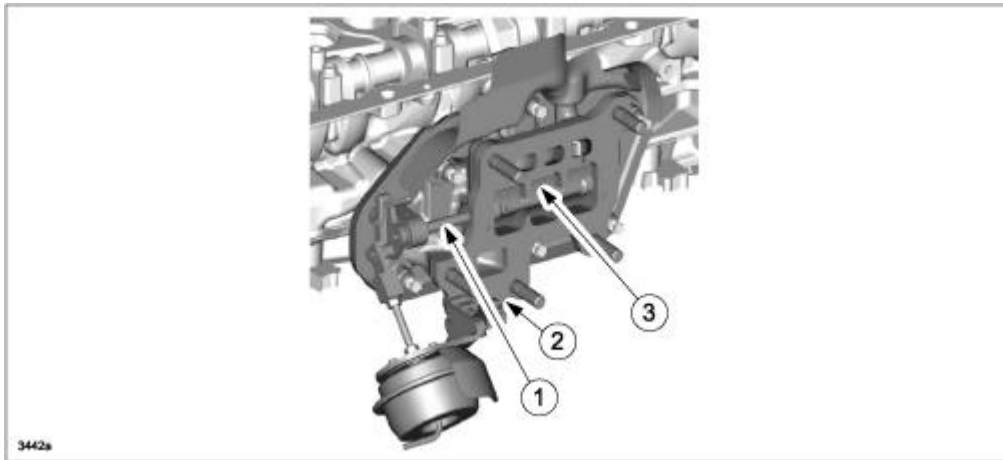

To eliminate this concern in the future, the production processes and controls have been improved.

**CONSUMER NOTICE:** The information and instructions in this bulletin are intended for use by skilled technicians. Mazda technicians utilize the proper tools/equipment and take training to correctly and safely maintain Mazda vehicles. These instructions should not be performed by "do-it-yourselfers." Customers should not assume this bulletin applies to their vehicle or that their vehicle will develop the described concern. To determine if the information applies, customers should contact their nearest authorized Mazda dealership. Mazda North American Operations reserves the right to alter the specifications and contents of this bulletin without obligation or advance notice. All rights reserved. No part of this bulletin may be reproduced in any form or by any means, electronic or mechanical---including photocopying and recording and the use of any kind of information storage and retrieval system ---without permission in writing.

## REPAIR PROCEDURE

1. Verify that DTCs P0302:00 and/or P0303:00 are stored in memory.

**NOTE:** DTCs P0302:00 and/or P0303:00 may not be stored because they are set after the continuous misfire for 2 drive cycles. If this is the case, verify that one or both of following conditions are met.

- If possible, confirm with the customer that the misfire and the check engine light started flashing at the same time.
- DTC U0401:00 is stored in memory.

**NOTE:** If there is any other engine related DTC(s) stored, diagnose and repair it accordingly.

2. If one or both of the above conditions are met, remove the exhaust manifold and verify that there are contact mark(s) on the exhaust manifold variable housing caused by the variable valve, as shown below.



3. If contact mark(s) are found, replace the exhaust manifold with a modified one according to the instructions on MGSS online (EXHAUST SYSTEM REMOVAL/INSTALLATION [SKYACTIV-G 2.5T]).

**NOTE:** There may be a crack found in the turbocharger housing, as shown below. The crack does not affect engine performance or cause any noise, so turbocharger replacement is not necessary.

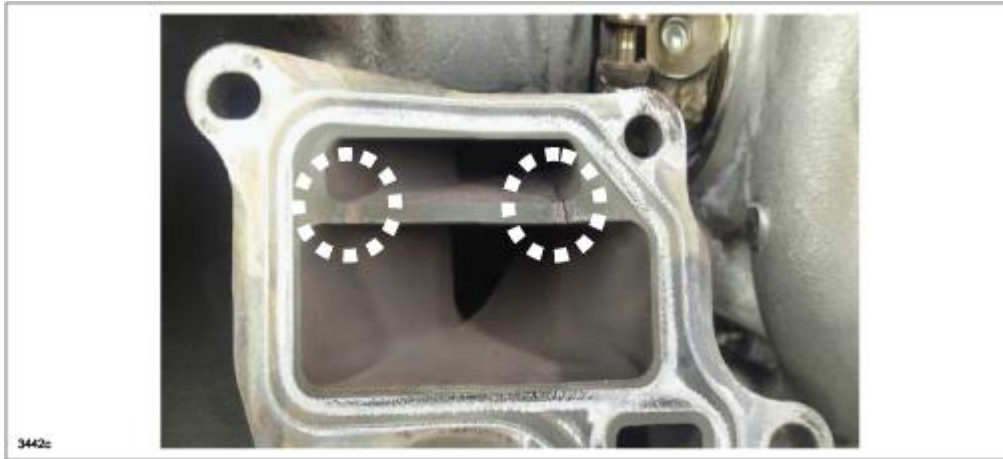

## PARTS INFORMATION

Part Number	Description	Qty.	Notes
PY8V-13-450F	Manifold, Exhaust	1	Replace with modified part
PY8V-13-460	Gasket, Exhaust Manifold	1	Replace
PY88-13-465	Nut, Exhaust Manifold	5	Replace
SH01-13-465	Nut, Exhaust Manifold	6	Replace
PY88-13-490	Gasket, Exhaust Manifold	1	Replace
PY8V-13-710B	Gasket, Turbocharger	1	Replace
PE23-40-305	Gasket	2	Replace
9994-61-000	Nut	4	Replace

**CONSUMER NOTICE:** The information and instructions in this bulletin are intended for use by skilled technicians. Mazda technicians utilize the proper tools/equipment and take training to correctly and safely maintain Mazda vehicles. These instructions should not be performed by "do-it-yourselfers." Customers should not assume this bulletin applies to their vehicle or that their vehicle will develop the described concern. To determine if the information applies, customers should contact their nearest authorized Mazda dealership. Mazda North American Operations reserves the right to alter the specifications and contents of this bulletin without obligation or advance notice. All rights reserved. No part of this bulletin may be reproduced in any form or by any means, electronic or mechanical---including photocopying and recording and the use of any kind of information storage and retrieval system ---without permission in writing.

Part Location

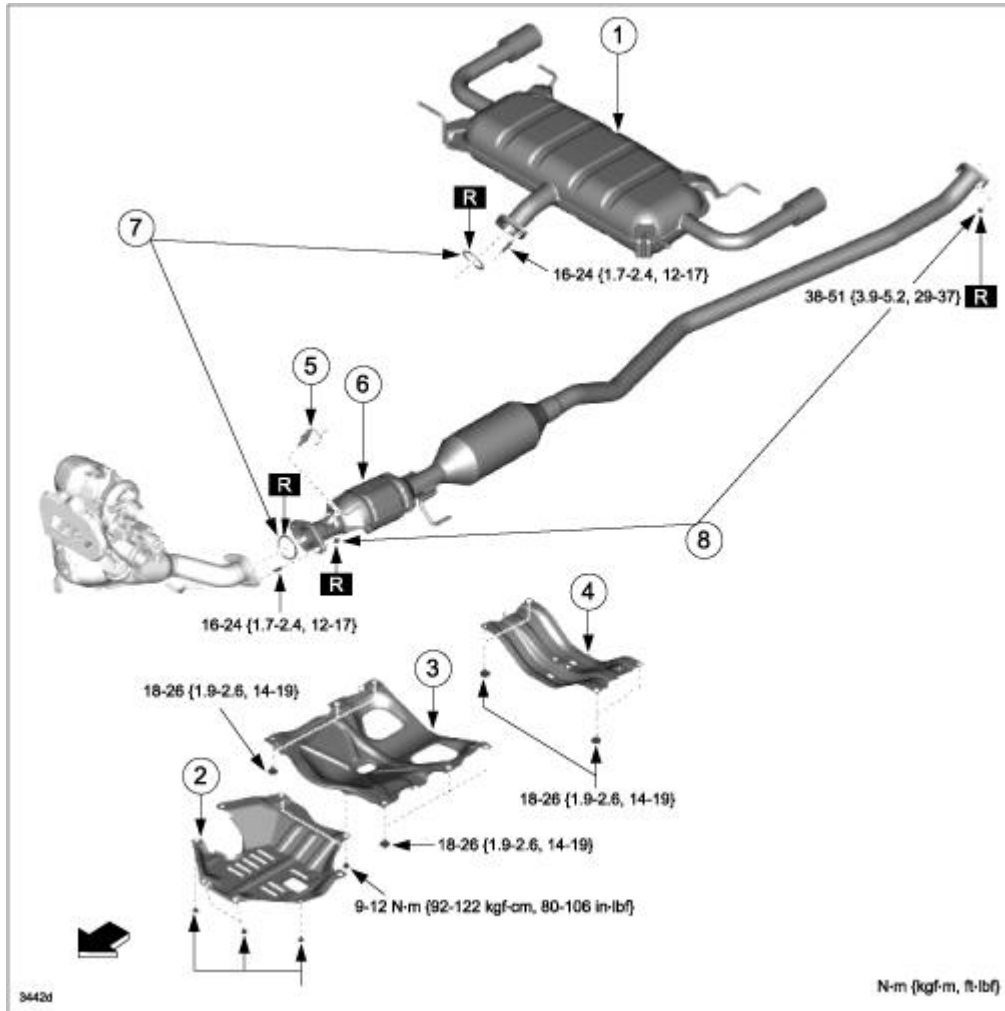

1	Main silencer	5	HO2S
2	Plate	6	TWC
3	Brace bar	7	Gasket (2) <b>(Replace)</b>
4	Tunnel Member	8	Nut (4) <b>(Replace)</b>

**CONSUMER NOTICE:** The information and instructions in this bulletin are intended for use by skilled technicians. Mazda technicians utilize the proper tools/equipment and take training to correctly and safely maintain Mazda vehicles. These instructions should not be performed by "do-it-yourselfers." Customers should not assume this bulletin applies to their vehicle or that their vehicle will develop the described concern. To determine if the information applies, customers should contact their nearest authorized Mazda dealership. Mazda North American Operations reserves the right to alter the specifications and contents of this bulletin without obligation or advance notice. All rights reserved. No part of this bulletin may be reproduced in any form or by any means, electronic or mechanical---including photocopying and recording and the use of any kind of information storage and retrieval system ---without permission in writing.

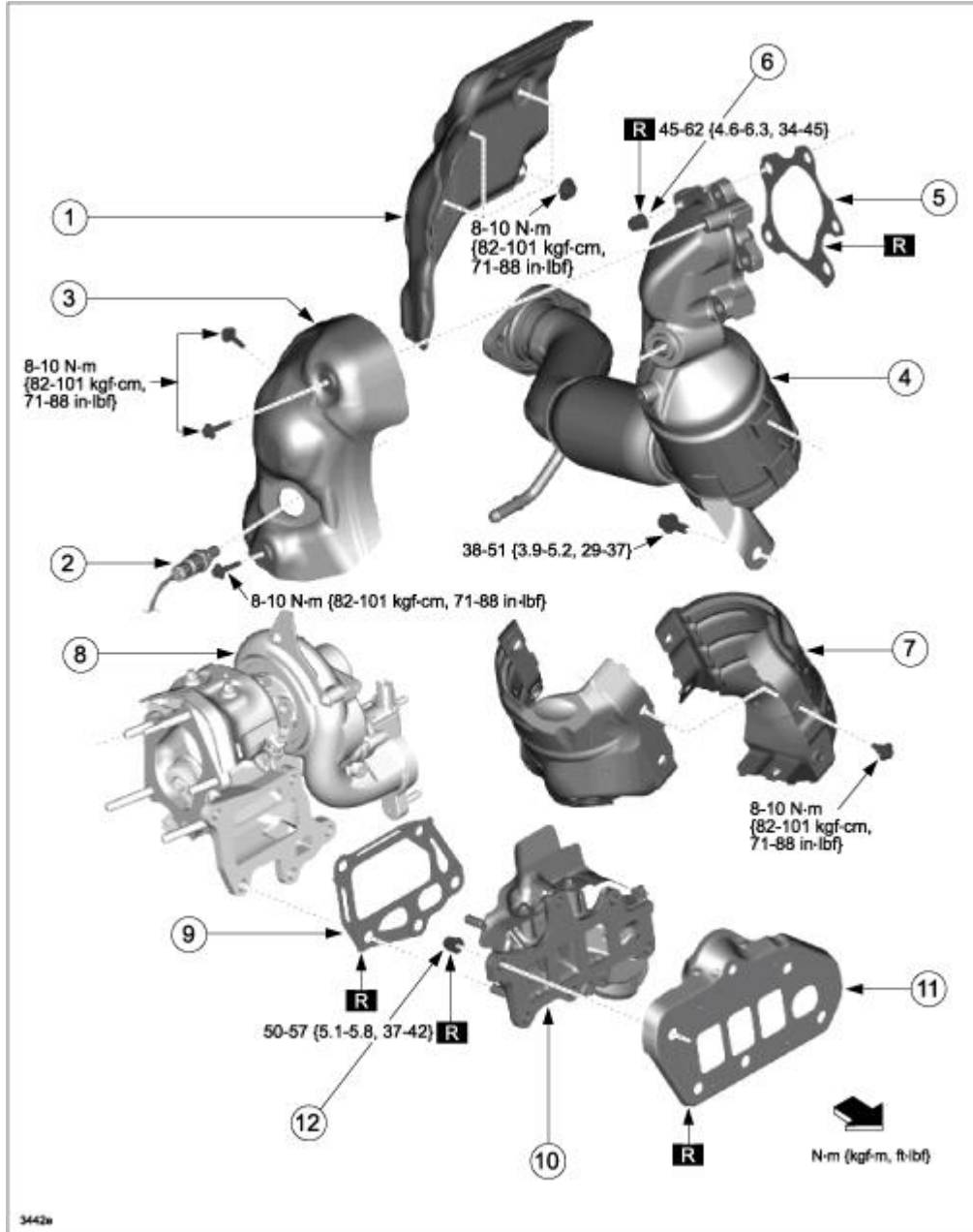

**CONSUMER NOTICE:** The information and instructions in this bulletin are intended for use by skilled technicians. Mazda technicians utilize the proper tools/equipment and take training to correctly and safely maintain Mazda vehicles. These instructions should not be performed by "do-it-yourselfers." Customers should not assume this bulletin applies to their vehicle or that their vehicle will develop the described concern. To determine if the information applies, customers should contact their nearest authorized Mazda dealership. Mazda North American Operations reserves the right to alter the specifications and contents of this bulletin without obligation or advance notice. All rights reserved. No part of this bulletin may be reproduced in any form or by any means, electronic or mechanical---including photocopying and recording and the use of any kind of information storage and retrieval system ---without permission in writing.

1	Insulator No.1	7	Insulator No.3
2	A/F sensor	8	Turbocharger
3	Insulator No.2	9	Gasket, Turbocharger <b>(Replace)</b>
4	WU-TWC	10	Exhaust Manifold <b>(Replace)</b>
5	Gasket, WU-TWC <b>(Replace)</b>	11	Gasket, Exhaust Manifold <b>(Replace)</b>
6	Nut, WU-TWC (5) <b>(Replace)</b>	12	Nut, Exhaust Manifold (6) <b>(Replace)</b>

## WARRANTY INFORMATION

### NOTE:

- This warranty information applies only to verified customer complaints on vehicles eligible for warranty repair.
- This repair will be covered under Mazda's Powertrain Limited Warranty.
- Additional diagnostic time cannot be claimed for this repair.

Warranty Type	A
Symptom Code	6X
Damage Code	9G
Part Number Main Cause	PY8V-13-450F
Quantity	1
Operation Number / Labor Hours:	XXP34ARX / 4.3 Hrs. (2WD) XXP34CRX / 4.2 Hrs. (4WD)

**NOTE:** Enter other replaced parts in Related Parts.

**CONSUMER NOTICE:** The information and instructions in this bulletin are intended for use by skilled technicians. Mazda technicians utilize the proper tools/equipment and take training to correctly and safely maintain Mazda vehicles. These instructions should not be performed by "do-it-yourselfers." Customers should not assume this bulletin applies to their vehicle or that their vehicle will develop the described concern. To determine if the information applies, customers should contact their nearest authorized Mazda dealership. Mazda North American Operations reserves the right to alter the specifications and contents of this bulletin without obligation or advance notice. All rights reserved. No part of this bulletin may be reproduced in any form or by any means, electronic or mechanical---including photocopying and recording and the use of any kind of information storage and retrieval system ---without permission in writing.