

Technical Service Bulletin

Mazda North American Operations
Irvine, CA 92618-2922



Subject: WRINKLES ON LEATHER SEAT SURFACE OF NEW VEHICLE	Bulletin No.: 09-015/18
	Last Issued: 03/22/2018

BULLETIN NOTES

- This bulletin supersedes the previously issued bulletin(s) listed below: The changes are noted in Red text.
- This service bulletin is only for sublet repair. A qualified upholstery repair specialist is required for this repair procedure.
- Please print a copy of this bulletin for the upholstery repair specialist.

Previously issued TSBs:	Date issued:
09-016/16	03/07/2016 and 06/22/16
09-015/12	03/23/2012

APPLICABLE MODEL(S)/VINS

2015-2018 Mazda3	2015-2018 Mazda6	2015-2018 CX-5	2015-2018 MX-5
2015-2015 Mazda5	2016-2018 CX-3	2015-2018 CX-9	

DESCRIPTION

At PDI or when new vehicle is delivered, some customers may complain about wrinkles on the leather seat cushion and/or seat back surface.

Customers having this concern should have their vehicle repaired by a qualified upholstery repair specialist using the following repair procedure.

CONSUMER NOTICE: The information and instructions in this bulletin are intended for use by skilled technicians. Mazda technicians utilize the proper tools/equipment and take training to correctly and safely maintain Mazda vehicles. These instructions should not be performed by "do-it-yourselfers." Customers should not assume this bulletin applies to their vehicle or that their vehicle will develop the described concern. To determine if the information applies, customers should contact their nearest authorized Mazda dealership. Mazda North American Operations reserves the right to alter the specifications and contents of this bulletin without obligation or advance notice. All rights reserved. No part of this bulletin may be reproduced in any form or by any means, electronic or mechanical---including photocopying and recording and the use of any kind of information storage and retrieval system ---without permission in writing.

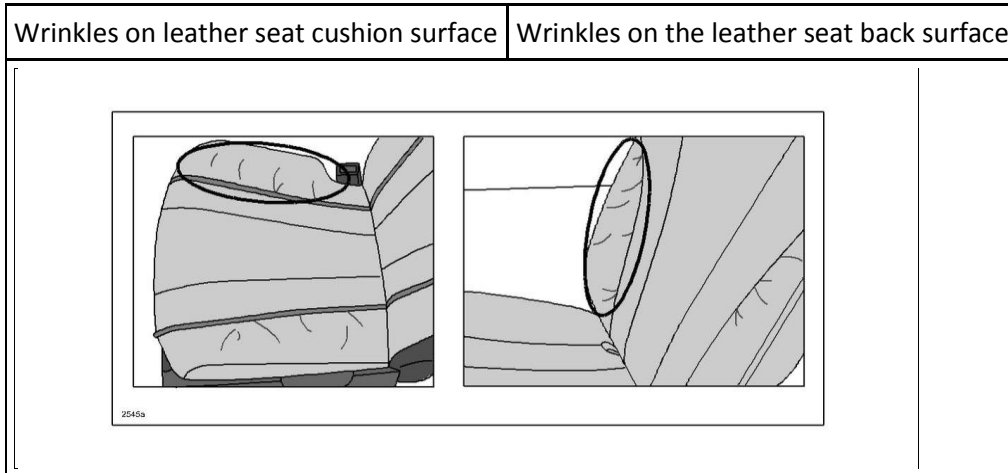
**NOTE:**

- A qualified upholstery repair specialist is required for this repair procedure.
- Explain to the customer before performing the repair that the wrinkles may not be completely removed.
- Explain to the customer that the leather may develop some wrinkles due to aging or wear during normal use. This is normal behavior of the leather material.

CONSUMER NOTICE: The information and instructions in this bulletin are intended for use by skilled technicians. Mazda technicians utilize the proper tools/equipment and take training to correctly and safely maintain Mazda vehicles. These instructions should not be performed by "do-it-yourselfers." Customers should not assume this bulletin applies to their vehicle or that their vehicle will develop the described concern. To determine if the information applies, customers should contact their nearest authorized Mazda dealership. Mazda North American Operations reserves the right to alter the specifications and contents of this bulletin without obligation or advance notice. All rights reserved. No part of this bulletin may be reproduced in any form or by any means, electronic or mechanical---including photocopying and recording and the use of any kind of information storage and retrieval system ---without permission in writing.

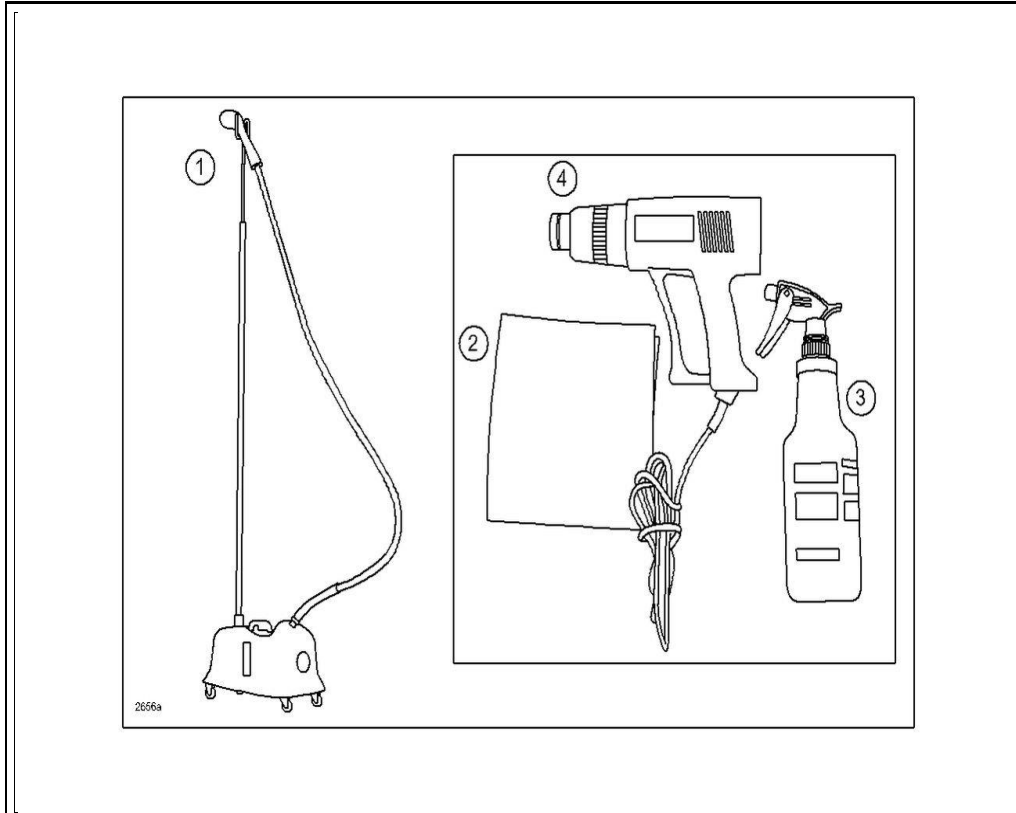

1	Steamer - Commercial type
2	Lint-free cloths
3	Spray bottle (with water)
4	(Optional) Heat gun with variable heat control

CONSUMER NOTICE: The information and instructions in this bulletin are intended for use by skilled technicians. Mazda technicians utilize the proper tools/equipment and take training to correctly and safely maintain Mazda vehicles. These instructions should not be performed by "do-it-yourselfers." Customers should not assume this bulletin applies to their vehicle or that their vehicle will develop the described concern. To determine if the information applies, customers should contact their nearest authorized Mazda dealership. Mazda North American Operations reserves the right to alter the specifications and contents of this bulletin without obligation or advance notice. All rights reserved. No part of this bulletin may be reproduced in any form or by any means, electronic or mechanical---including photocopying and recording and the use of any kind of information storage and retrieval system ---without permission in writing.

REPAIR PROCEDURE

There are two (2) repair methods available for this repair:

COMMERCIAL STEAMER METHOD	This is the preferred method. This method should resolve most customer concerns.
HEAT GUN METHOD	This is NOT the preferred method. Only use this method if the COMMERCIAL STEAMER METHOD is not sufficient.

COMMERCIAL STEAMER METHOD:

NOTE:

- A qualified upholstery repair specialist is required for this repair procedure.
- Always follow the manufactures instructions for the steamer and heat gun.
- Do not apply the steamer head directly to the perforated sections of the leather seat surface (A).

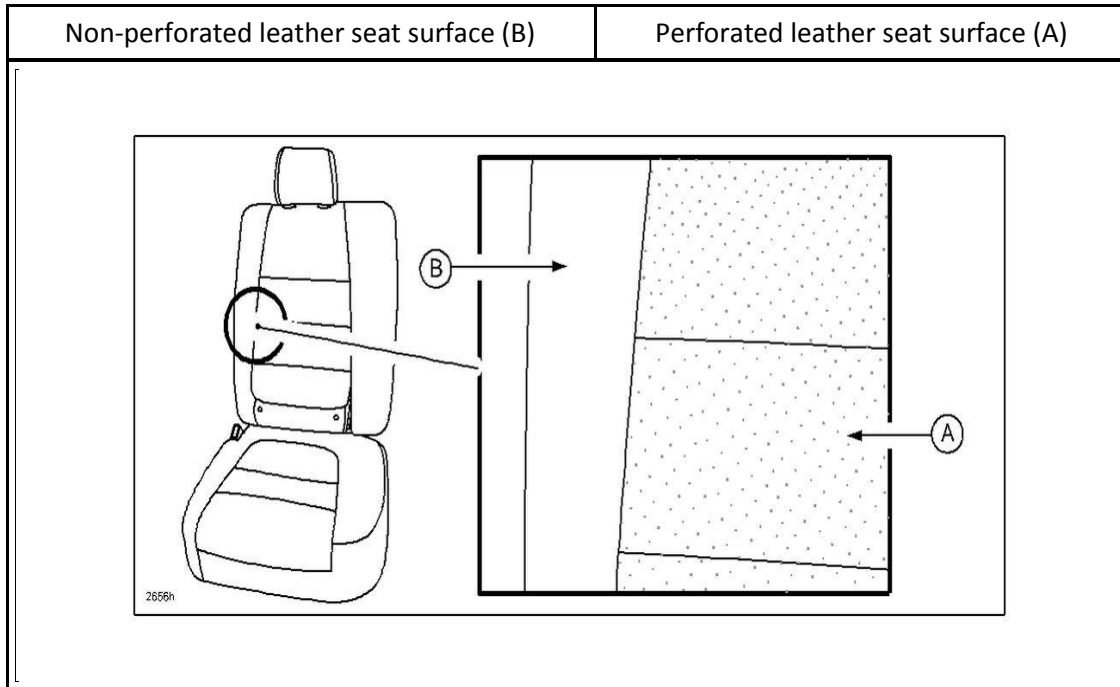

1. Use a clean lint-free cloth to cover all seat belt buckles.

CONSUMER NOTICE: The information and instructions in this bulletin are intended for use by skilled technicians. Mazda technicians utilize the proper tools/equipment and take training to correctly and safely maintain Mazda vehicles. These instructions should not be performed by "do-it-yourselfers." Customers should not assume this bulletin applies to their vehicle or that their vehicle will develop the described concern. To determine if the information applies, customers should contact their nearest authorized Mazda dealership. Mazda North American Operations reserves the right to alter the specifications and contents of this bulletin without obligation or advance notice. All rights reserved. No part of this bulletin may be reproduced in any form or by any means, electronic or mechanical---including photocopying and recording and the use of any kind of information storage and retrieval system ---without permission in writing.

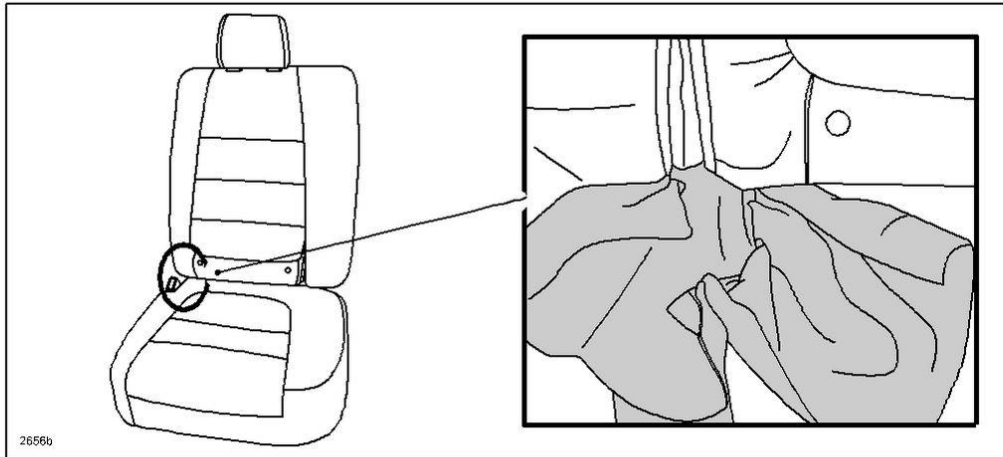
**CAUTION:**

- Do not spray water on the seat belt buckles.
- Do not apply the steamer head directly on the latch anchor location buttons.

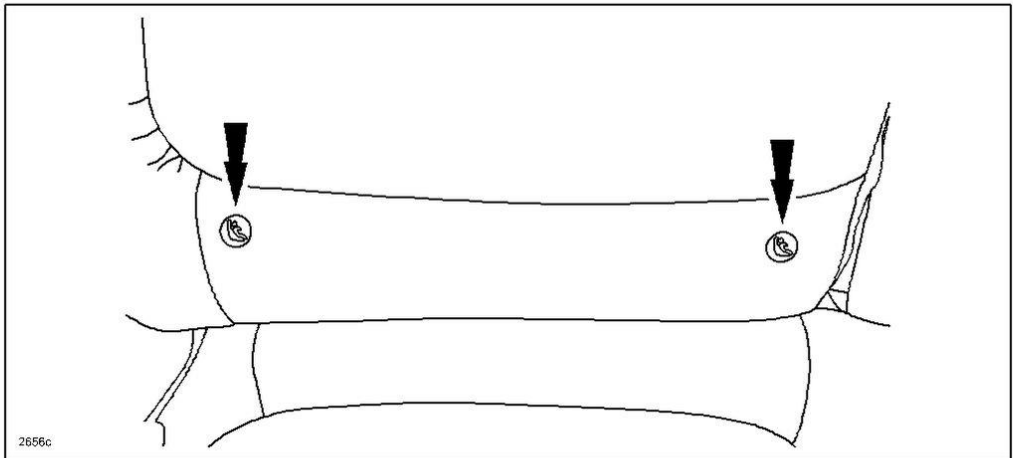

2. Choose one area at a time to work on. Apply the steamer head directly on the wrinkle until the upholstery material becomes warm. Move the steamer head in a outward motion (similar to ironing a shirt). Repeat until the wrinkles are removed to an acceptable level.

CAUTION: Do not apply steam directly on the perforated sections of the leather seat surface.

CONSUMER NOTICE: The information and instructions in this bulletin are intended for use by skilled technicians. Mazda technicians utilize the proper tools/equipment and take training to correctly and safely maintain Mazda vehicles. These instructions should not be performed by "do-it-yourselfers." Customers should not assume this bulletin applies to their vehicle or that their vehicle will develop the described concern. To determine if the information applies, customers should contact their nearest authorized Mazda dealership. Mazda North American Operations reserves the right to alter the specifications and contents of this bulletin without obligation or advance notice. All rights reserved. No part of this bulletin may be reproduced in any form or by any means, electronic or mechanical---including photocopying and recording and the use of any kind of information storage and retrieval system ---without permission in writing.

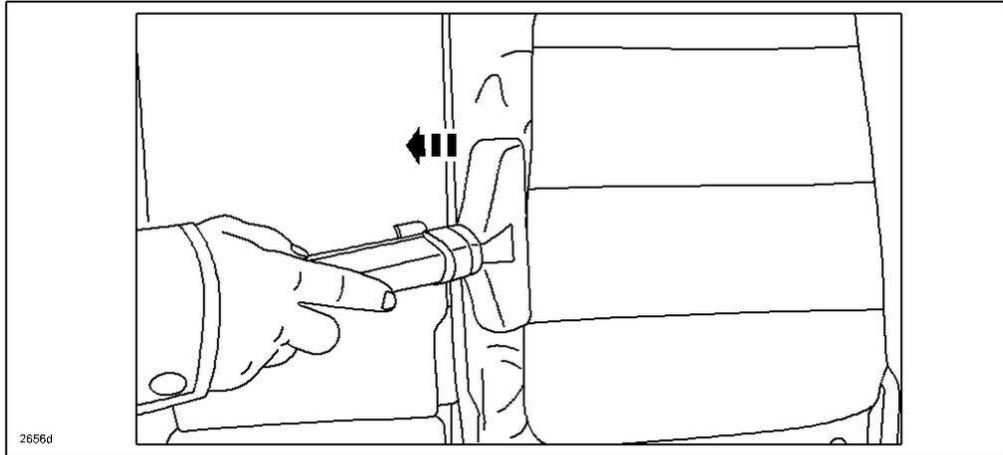

If necessary, use your hand to work out the wrinkles by applying firm pressure in a outward motion. This step can be repeated as long as the upholstery material is warm. If the upholstery material feels cool, re-apply steam.

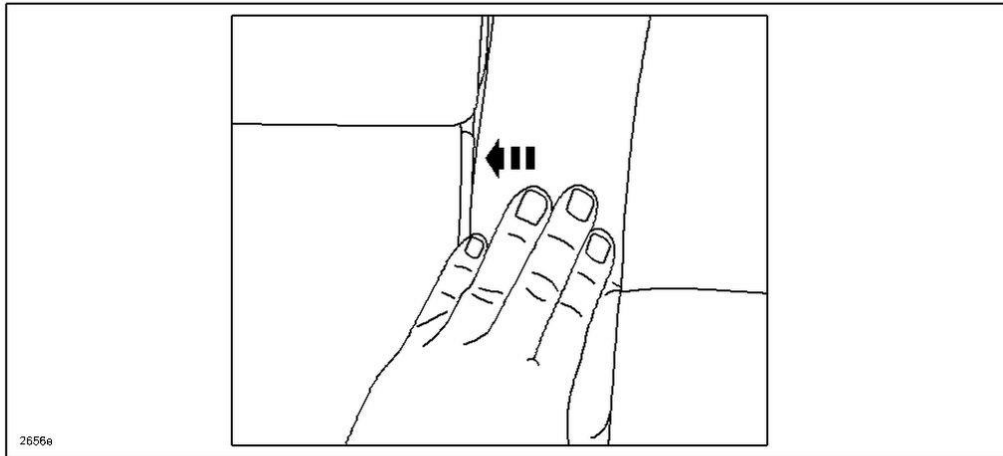

3. Repeat step #2 until the wrinkles are removed to an acceptable level.

NOTE: Direct heat may be necessary to aid in the removal of some wrinkles. Refer to HEAT GUN METHOD.

CONSUMER NOTICE: The information and instructions in this bulletin are intended for use by skilled technicians. Mazda technicians utilize the proper tools/equipment and take training to correctly and safely maintain Mazda vehicles. These instructions should not be performed by "do-it-yourselfers." Customers should not assume this bulletin applies to their vehicle or that their vehicle will develop the described concern. To determine if the information applies, customers should contact their nearest authorized Mazda dealership. Mazda North American Operations reserves the right to alter the specifications and contents of this bulletin without obligation or advance notice. All rights reserved. No part of this bulletin may be reproduced in any form or by any means, electronic or mechanical---including photocopying and recording and the use of any kind of information storage and retrieval system ---without permission in writing.

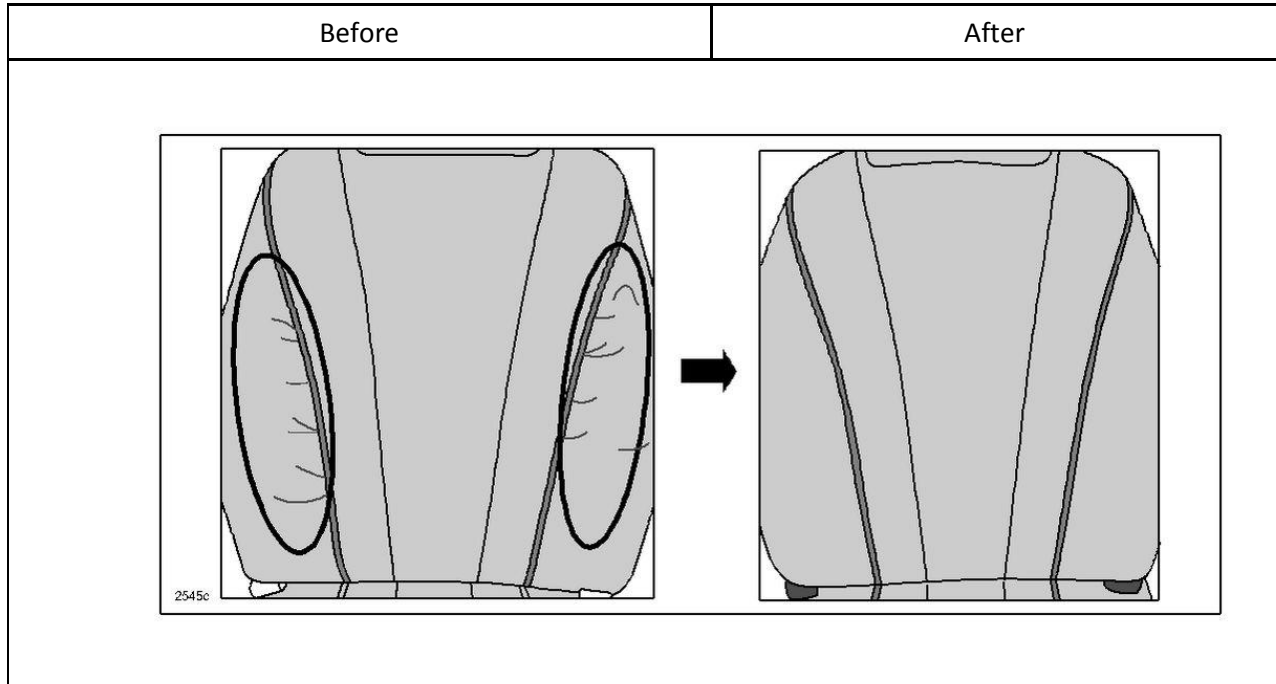
**CAUTION:**

- Do NOT keep the steamer head at the same place for a long time.
- Do NOT run the steamer head without a water-soaked cloth especially over seat trim beading and seat side trim area.
- Seat damage may occur if the caution points above are not followed as shown below.

CONSUMER NOTICE: The information and instructions in this bulletin are intended for use by skilled technicians. Mazda technicians utilize the proper tools/equipment and take training to correctly and safely maintain Mazda vehicles. These instructions should not be performed by "do-it-yourselfers." Customers should not assume this bulletin applies to their vehicle or that their vehicle will develop the described concern. To determine if the information applies, customers should contact their nearest authorized Mazda dealership. Mazda North American Operations reserves the right to alter the specifications and contents of this bulletin without obligation or advance notice. All rights reserved. No part of this bulletin may be reproduced in any form or by any means, electronic or mechanical---including photocopying and recording and the use of any kind of information storage and retrieval system ---without permission in writing.

Damaged Seat Side Trim

Damaged Seat Side Beading

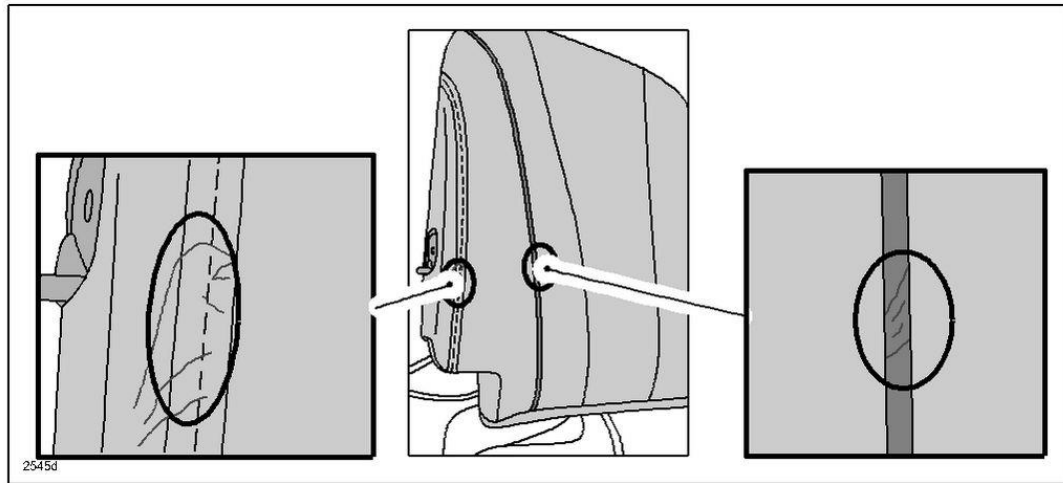
**HEAT GUN METHOD (optional)**

1. Use a water spray bottle to pre-soak a lint-free cloth. 2. Use a heat gun with variable heat control. Set the heat range to the lowest setting.

CAUTION:

- Do not apply direct heat on the perforated sections of the leather seat surface.
- Do not apply direct heat on the upholsteries' stitching or beading.
- Do not apply direct heat on the latch anchor location buttons.

Hold the heat gun at least 5 inches away from the upholstery material. Apply heat in a circular motion.

CONSUMER NOTICE: The information and instructions in this bulletin are intended for use by skilled technicians. Mazda technicians utilize the proper tools/equipment and take training to correctly and safely maintain Mazda vehicles. These instructions should not be performed by "do-it-yourselfers." Customers should not assume this bulletin applies to their vehicle or that their vehicle will develop the described concern. To determine if the information applies, customers should contact their nearest authorized Mazda dealership. Mazda North American Operations reserves the right to alter the specifications and contents of this bulletin without obligation or advance notice. All rights reserved. No part of this bulletin may be reproduced in any form or by any means, electronic or mechanical---including photocopying and recording and the use of any kind of information storage and retrieval system ---without permission in writing.

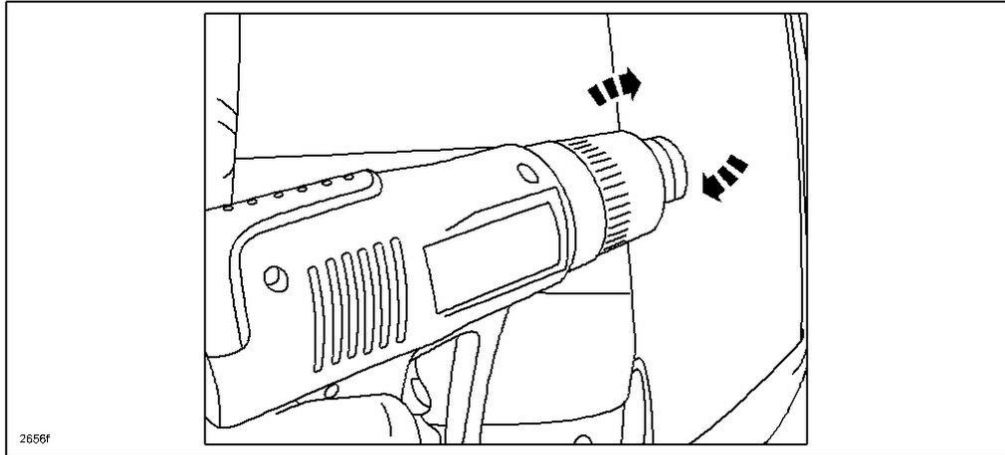

Once the upholstery material reaches a warm temperature, use the pre-soaked cloth to apply firm hand pressure in a outward motion.

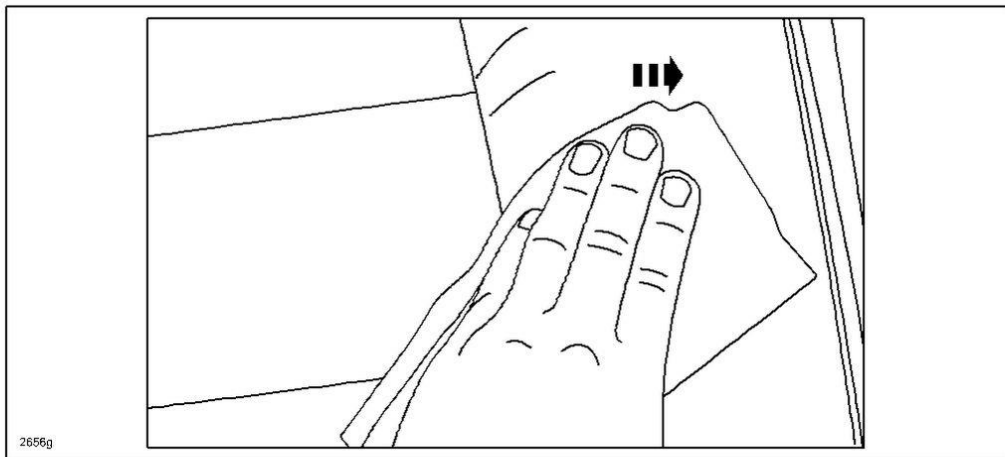

CONSUMER NOTICE: The information and instructions in this bulletin are intended for use by skilled technicians. Mazda technicians utilize the proper tools/equipment and take training to correctly and safely maintain Mazda vehicles. These instructions should not be performed by "do-it-yourselfers." Customers should not assume this bulletin applies to their vehicle or that their vehicle will develop the described concern. To determine if the information applies, customers should contact their nearest authorized Mazda dealership. Mazda North American Operations reserves the right to alter the specifications and contents of this bulletin without obligation or advance notice. All rights reserved. No part of this bulletin may be reproduced in any form or by any means, electronic or mechanical---including photocopying and recording and the use of any kind of information storage and retrieval system ---without permission in writing.

WARRANTY INFORMATION

NOTE:

- This warranty information applies only to verified customer complaints on vehicles eligible for warranty repair.
- This repair will be covered under Mazda's New Vehicle Limited Warranty term.
- Additional diagnostic time cannot be claimed for this repair.
- This service bulletin is only for sublet repair. A qualified upholstery repair specialist is required for this repair procedure.

		Note
Warranty Type	A	---
Symptom Code	87	---
Damage Code	9E	---
Part Number Main Cause	Refer to EPC part number of concerned seat	---
Quantity	0	---
Operation Number / Labor Hours:	XXG23ARX / 0.0 Hrs.	---
Sublet Allowance:	MM030XRX / 0.3 Hrs.	Sublet allowance can be claimed for administration tasks associated with the sublet repair

UPHOLSTERY REPAIR SHOP

Cost to repair leather seats

Sublet Invoice Number	Number from the upholstery repair shop invoice or dealer purchase order.
Sublet Type Code	Enter "F6"
Sublet Amount	Enter the upholster shop invoice amount. No mark-up allowed.

CONSUMER NOTICE: The information and instructions in this bulletin are intended for use by skilled technicians. Mazda technicians utilize the proper tools/equipment and take training to correctly and safely maintain Mazda vehicles. These instructions should not be performed by "do-it-yourselfers." Customers should not assume this bulletin applies to their vehicle or that their vehicle will develop the described concern. To determine if the information applies, customers should contact their nearest authorized Mazda dealership. Mazda North American Operations reserves the right to alter the specifications and contents of this bulletin without obligation or advance notice. All rights reserved. No part of this bulletin may be reproduced in any form or by any means, electronic or mechanical---including photocopying and recording and the use of any kind of information storage and retrieval system ---without permission in writing.