

April 03, 2018

08661 Version 2

Front Brakes Squeal

Supersedes 17-040, dated December 21, 2017, to revise the information highlighted in **yellow**

REVISION SUMMARY

Updated the VIN Range under **AFFECTED VEHICLES**.

AFFECTED VEHICLES

Year	Model	Trim	VIN Range
2014–17	RLX (non-hybrid)	ALL	ALL
2018	RLX (non-hybrid)	ALL	JH4KC1...JC000001 thru JH4KC1... JC000527

SYMPTOM

The front brakes squeal when braking at slow speeds after the brakes are warm (after approximately 20 miles or 30 minutes of driving).

POSSIBLE CAUSES

Glazing on the front brake pads and/or rotors.

CORRECTIVE ACTION

Resurface the rotors, and replace the front brake pads and shims.

TOOL INFORMATION

Part Name	Part Number	Quantity
Brake Caliper Piston Compressor Tool (or equivalent)	07AAE-SEPA101	1

PARTS INFORMATION

Part Name	Part Number	Quantity
Front Brake Pad Kit	45022-TY2-A03	1

WARRANTY CLAIM INFORMATION

The normal warranty applies.

Operation Number	Description	Flat Rate Time	Defect Code	Symptom Code	Template ID	Failed Part Number
410150	Replace the brake pads and shims.	0.4 hr	01401	04201	B17040B	45022-TY2-A01
A	Resurface rotors.	0.5 hr				

Skill Level: Repair Technician

CLIENT INFORMATION: The information in this bulletin is intended for use only by skilled technicians who have the proper tools, equipment, and training to correctly and safely maintain your vehicle. These procedures should not be attempted by "do-it-yourselfers," and you should not assume this bulletin applies to your vehicle, or that your vehicle has the condition described. To determine whether this information applies, contact an authorized Acura automobile dealer.

REPAIR PROCEDURE

1. Remove some brake fluid from the master cylinder reservoir.
2. Raise the vehicle on a lift.
3. Remove the front wheels.
4. Remove the flange bolt while holding the caliper pin and lift the caliper body up out of the way.

NOTE:

- Be careful not to damage the pin boot.
- Be careful when pivoting the caliper body up, the spring may pop out of position.
- Check the hose and pin boots for damage and deterioration.

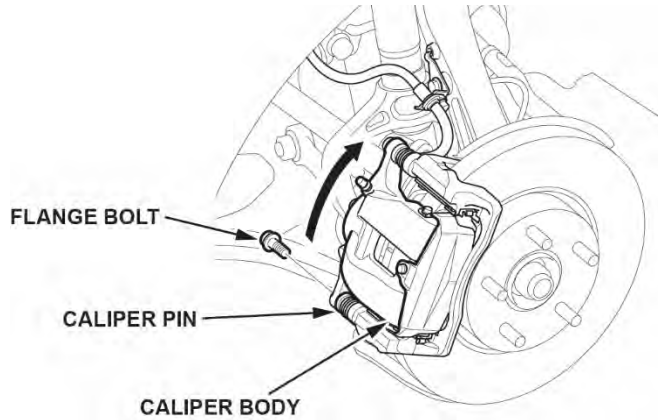

5. Remove the pad return spring. Do not reuse.

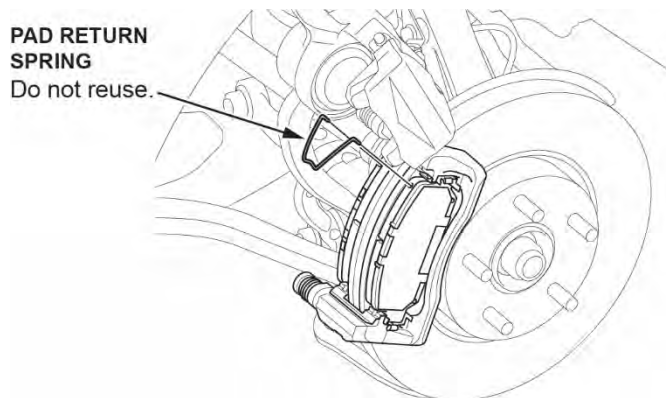

6. Remove the pad shims and the brake pads.

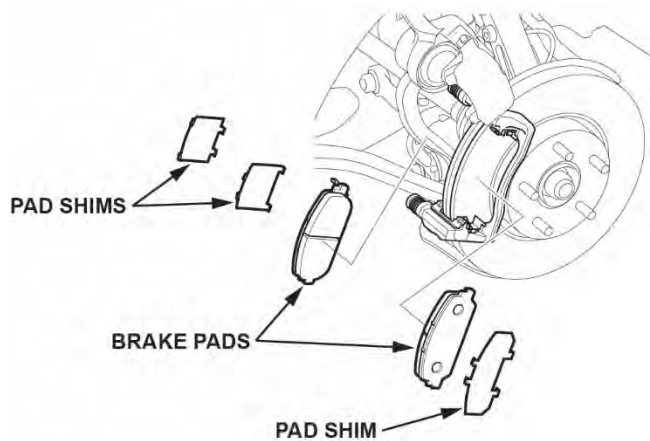

7. Remove the pad retainers.

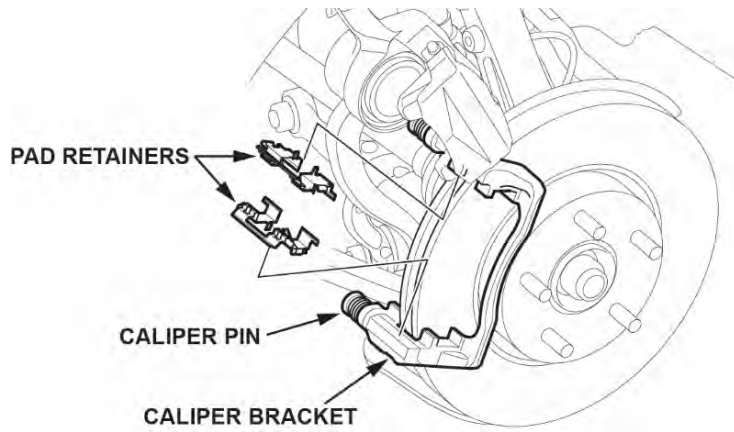

8. Clean the caliper bracket and verify that the caliper pins move in and out smoothly. Clean and lube if needed.
9. Resurface the rotors. Refer to the service information.
10. Apply a thin coat of M-77 assembly paste to the retainer mating surface of the caliper bracket, and install the pad retainers.

NOTE: Wipe off any excess assembly paste and keep the assembly paste away from the brake disc and brake pad surfaces.

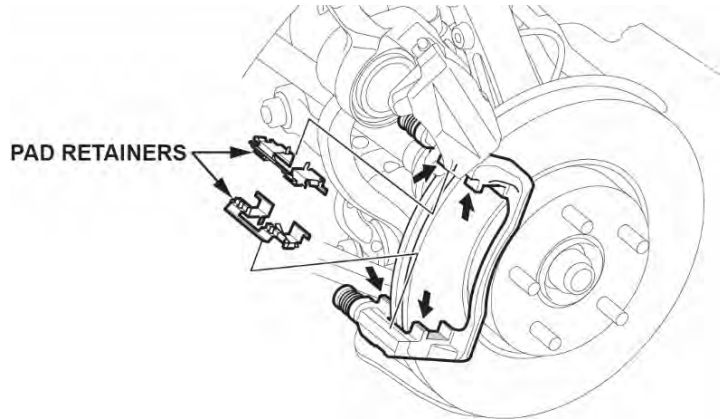

11. Install the brake caliper piston compressor tool (T/N 07AAE-SEPA101) on the caliper body.

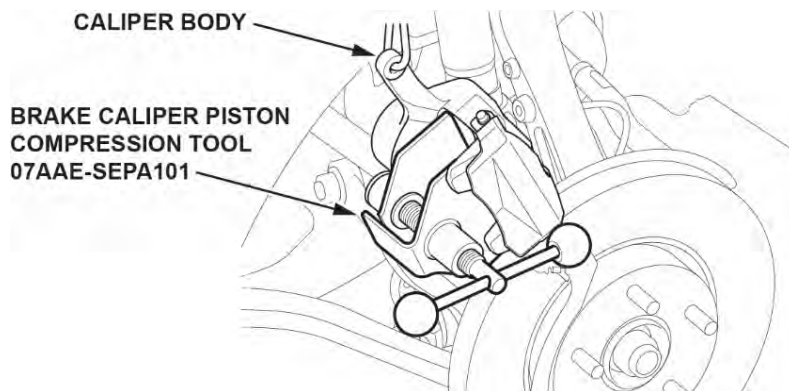

12. Press in the piston with the brake caliper piston compressor tool.

NOTE: Be careful when pressing in the piston, brake fluid may overflow from the master cylinder's reservoir. If brake fluid gets on any painted surface, wash it off immediately with water.

13. Remove the brake caliper piston compressor tool.

14. Organize the new countermeasure shims with the correct pads before installing. The shims are marked "R" and "L", and should not be interchanged.

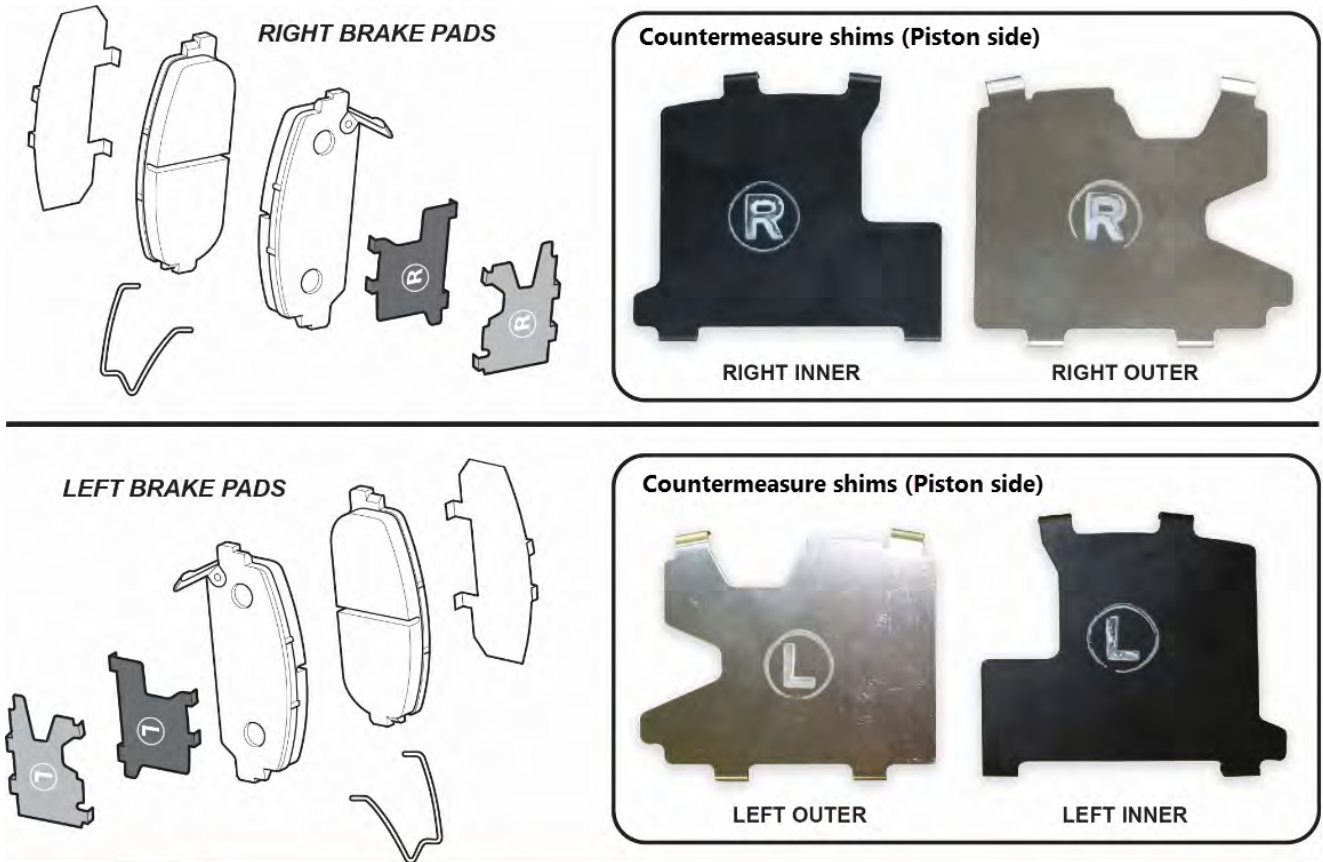

15. Apply a thin coat of M-77 assembly paste to the pad side of the shims, the back of the brake pads, and the other areas indicated by the arrows.
- NOTE: Wipe off any excess assembly paste and keep the assembly paste away from the brake disc and brake pad surfaces.

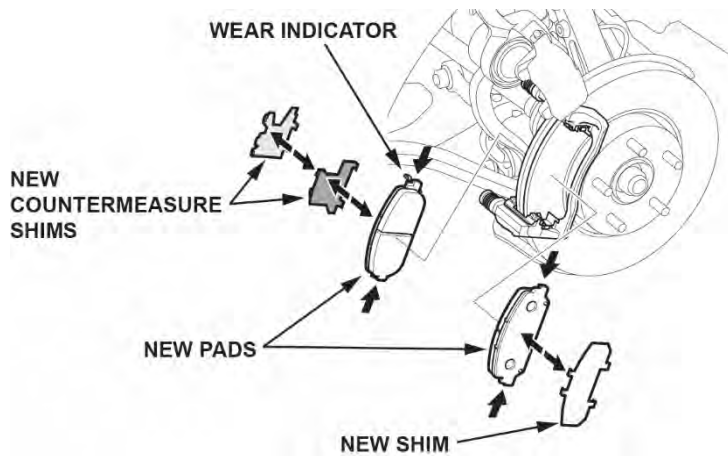

16. Install the new brake pads and pad shims, make sure the brake pad wear indicator is facing up.

17. Install the pad return spring.

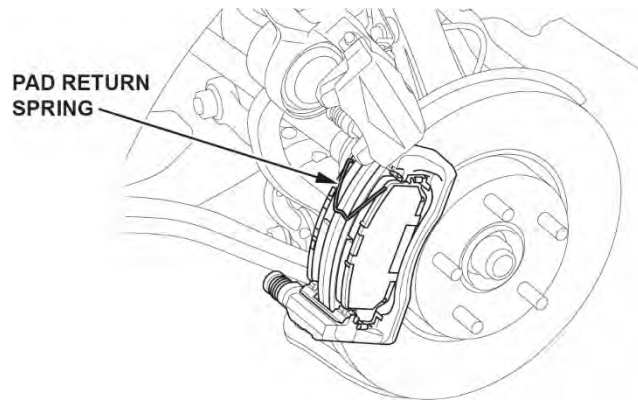

18. Pull the caliper body down into position.

19. Install the flange bolt and torque it to **50 N·m (37 lb-ft)** while holding the caliper pin in place.

NOTE: Be careful not to damage the pin boot.

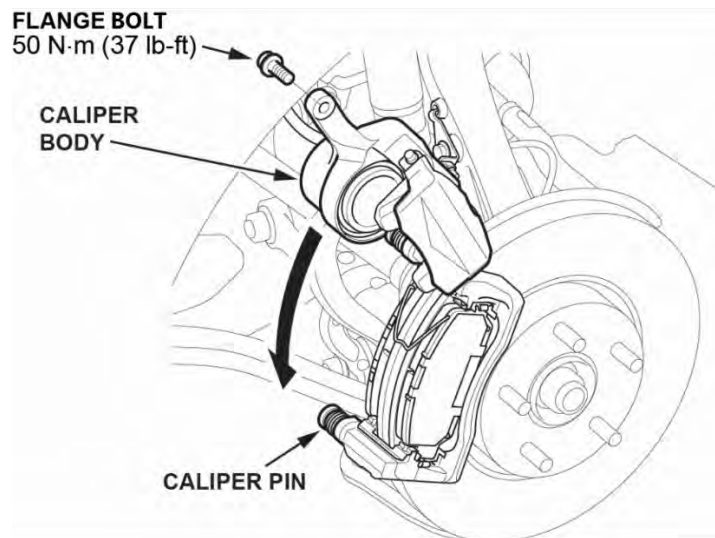

20. Press the brake pedal several times to make sure the brakes work properly.

21. Install the front wheels.

22. Add brake fluid to master cylinder as needed.

END