

24V to 12V CONVERTER INSTALLATION

Vehicles involved are the Volvo 9700 Series.

REFER TO PART A OR B ACCORDING TO THE VIN		
PART	VIN	PAGE #
A	VEHICLES PRIOR I-START FROM 3CET2V220 <u>G5177311</u> to 3CET2V923J5188042	2
B	VEHICLES EQUIPPED WITH I-START FROM 3CET2V925J518 <u>8043</u> AND NEWER	6



DANGER

Park vehicle safely, apply parking brake, stop engine. In the battery box, set the battery cut-off switch to the OFF position prior to working on the vehicle.

NOTE

Material can be obtained through regular channels.

PART A

MATERIAL

Order kit #IS-18900 which contains the following parts:

Part No.	Description	Qty
7775098	24V TO 12V CONVERTER, 15 AMP.	1
560671	WIRE, 12 AWG, GXL, BLACK, 125 deg (feet)	5
560667	WIRE, 12 AWG, GXL, RED, 125 deg (feet)	5
7775120	SELF DRILLING HEX SCREW 12 X 3/4 ZP	5
7775121	FUSE HOLDER	1
562604	15 AMP. FUSE	1
562230	BUTT TERMINAL 12-10	1
561246	EYELET 3/8' 12-10 AWG' (yellow)	2
N55439-13	FORK TERMINAL 12-10 AWG (yellow) DURASEAL	2
560784	SHRINK TUBING DOUBLE WALL, 0.25"-0.08" (ft)	0.5
IS18900	INSTRUCTION SHEET	1
FI18900	FEUILLE D'INSTRUCTION	1

Other parts that may be required:

Part No.	Description	Qty
504637	CABLE TIE, NYLON BLACK MIDDLE SIZE	6

PROCEDURE

1. Prepare wiring before to install parts on the vehicle.
2. Connect one wire of the fuse holder with the red wire supplied in the kit. Use butt splice (item 1, Figure 1). Solder the wires with the butt splice.
3. Insert a 2" long shrink tubing (item 2, Figure 1) over the previous connection and heat to shrink as shown on Figure 1.

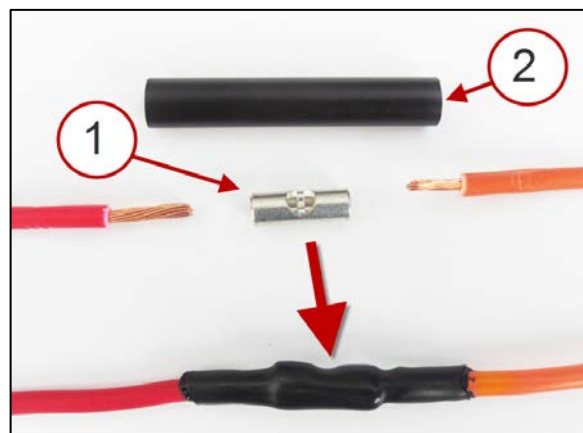

FIGURE 1

4. Complete the wiring as shown on Figure 2.

- 1- 7775121
- 2- 562604
- 3- 562230
- 4- 560784
- 5- 560667
- 6- 560671
- 7- N55439-13
- 8- 561246

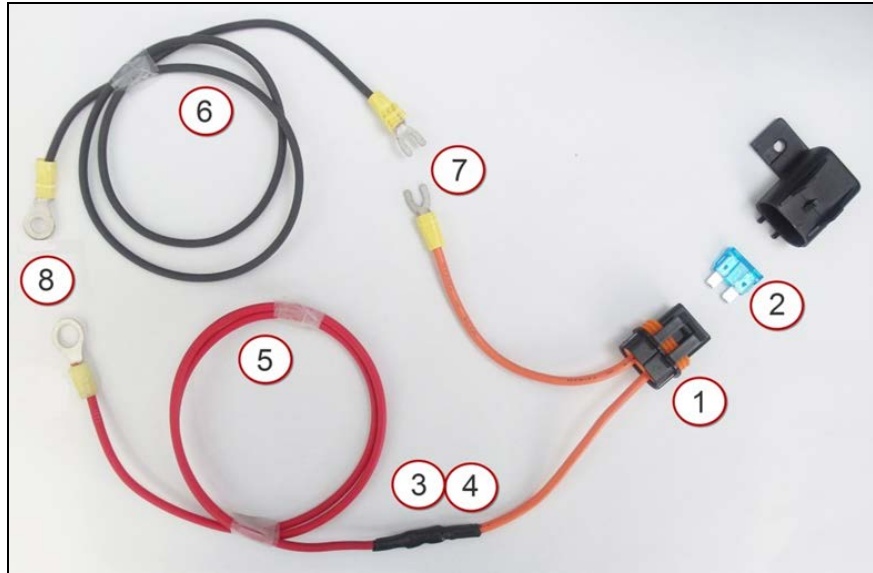

FIGURE 2

5. Locate the main electrical compartment (Figure 3).
6. Open and slide up the door to remove it.



FIGURE 3

7. Before installing the converter on the wall of the electrical compartment, connect the fuse holder wire with the fork terminal to the input connection of the converter (Figure 4).
8. Connect the fork terminal of the black wire with one of the ground (GND) connection of the converter (Figure 4).

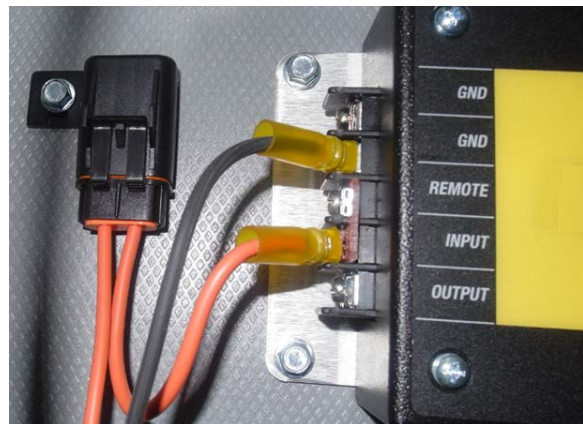

FIGURE 4

9. Install the converter on the top of the wall, on your right when facing the electrical compartment. Use four self-drilling screws. Wiring must be on the left side (Figure 5).

NOTE

The wall is made of plastic and wood. Do not tighten to much the screws.

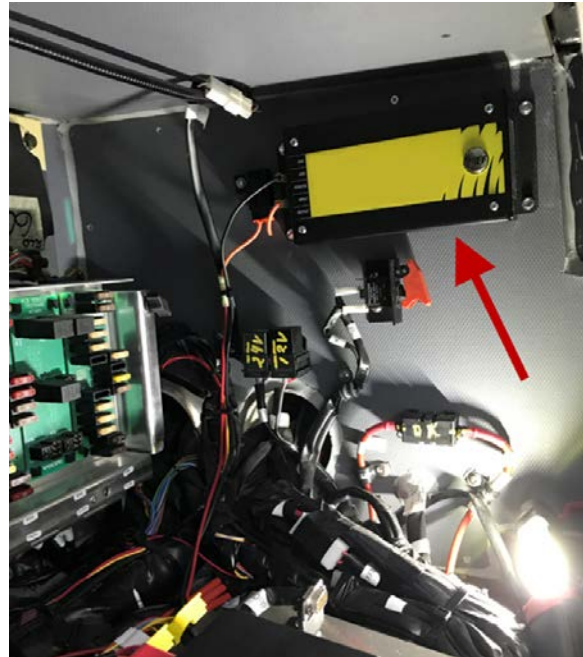

FIGURE 5

10. Install the fuse holder on the left side of the converter with one self-drilling screw and the wires downward (Figure 6).

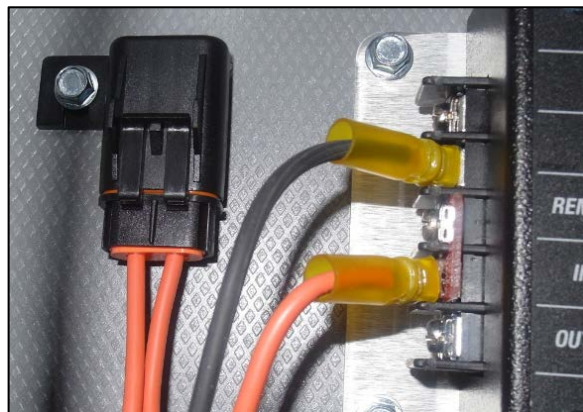

FIGURE 6

11. Locate the central electrical box (Figure 7). The studs for the power supply are behind that box.



FIGURE 7

12. Connect the red wire with the 3/8" ring terminal to the +30 connection (Figure 8) and tighten the stud nut to torque value between 15 lb-ft and 18 lb-ft.
13. Connect the black wire with the 3/8" ring terminal to the ground connection (Figure 8) and tighten the stud nut to torque value between 15 lb-ft and 18 lb-ft.
14. Cover the connections with the red plastic covers.
15. Use cable ties to hold the new wiring with the existing cables.

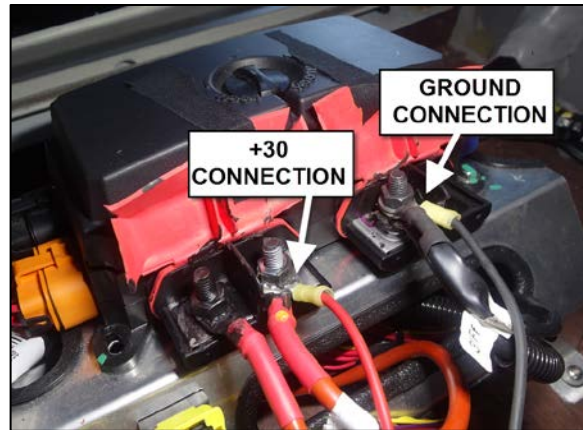

FIGURE 8

16. Use the electrical diagram shown in Figure 9 to verify the connections.

NOTE
For more information, refer to the Supplier section on the Technical Publications web site by clicking this link:
<https://techpub.prevestcar.com>
Search for "ITC" as the supplier name.

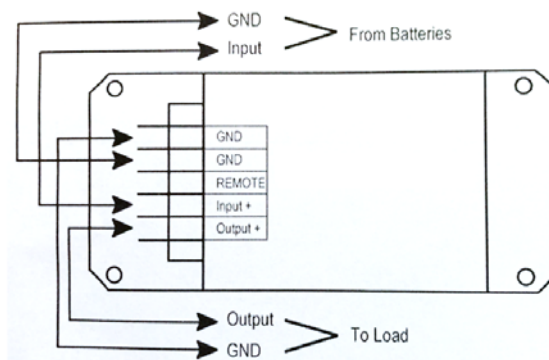

FIGURE 9

17. Test the converter with a voltmeter. Turn the ignition switch to the "ON" position. Use the converter Output connection for positive (item A, Figure 10) and the Ground connection (GRN, item B, Figure 10). The value should be around 13.8V.

NOTE
The minimum AWG rating to transfer max current of this converter is 1.5mm (14 GA.).

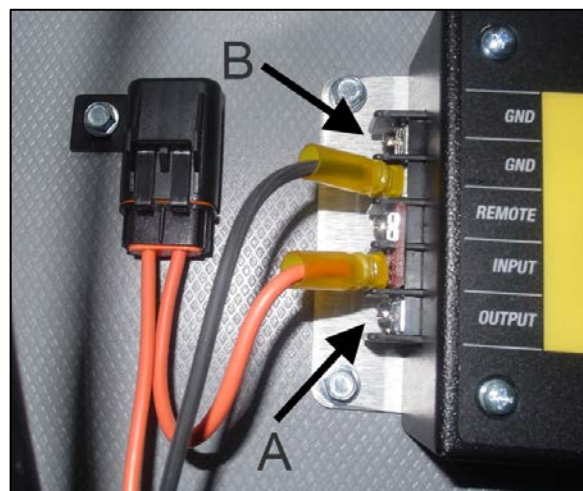

FIGURE 10

18. Bulletin is complete for this vehicle.

PART B

MATERIAL

Order kit #IS-18900_2 which contains the following parts:

Part No.	Description	Qty
20724975	24V TO 12V CONVERTER, 20 AMP.	1
7775120	SELF DRILLING HEX SCREW 12 X 3/4 ZP	2
20375162	TERMINAL	2
IS18900	INSTRUCTION SHEET	1
FI18900	FEUILLE D'INSTRUCTION	1

PROCEDURE

19. Locate the access panel of the audio/video electrical compartment (Figure 11).



FIGURE 11

20. Remove the access panel (Figure 12).



FIGURE 12

21. If you are ready to connect a client electronic device to the converter 12V output, install terminal #20375162 to the positive wire of that device and install the terminal into connector T 901 to connect to pin #2 of the converter connector.



FIGURE 13

22. Connect connector T 901 to the converter (Figure 14).

23. Test the converter with a voltmeter. Turn the ignition switch to the "ON" position. Back probe the connector. Use pin #2 for positive and #6, #8 or #9 or structure for ground. The value should be around 14V.

NOTE

The minimum AWG rating to transfer max current of this converter is 2.5mm (10 GA.).

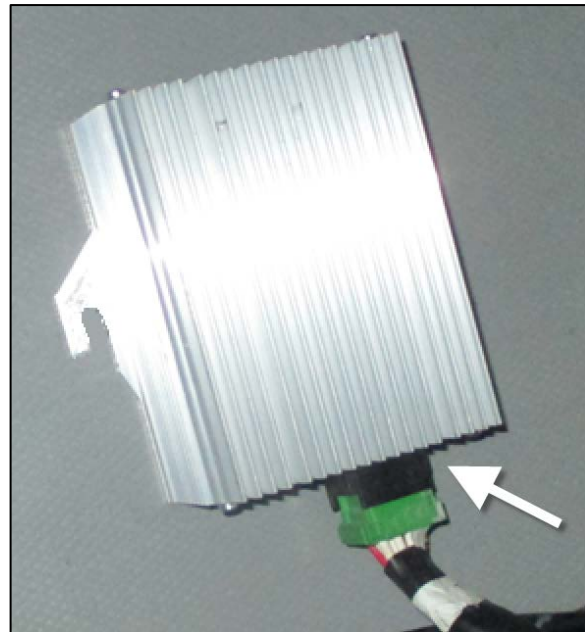

FIGURE 14

24. Install the converter (item A, Figure 15) on the wall with two self-drilling screws (item B, Figure 15).

NOTE

The wall is made of plastic and wood. Do not tighten to much the screws.

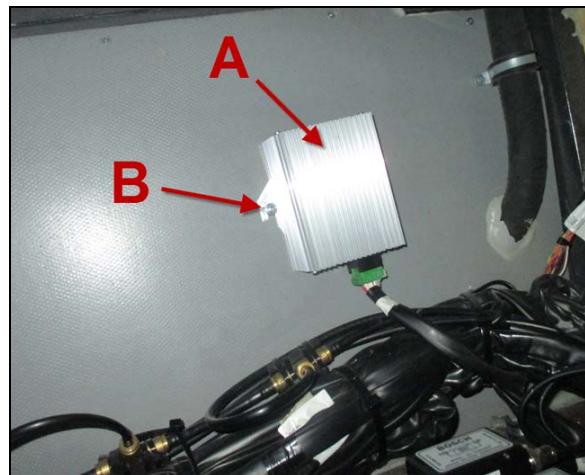

FIGURE 15

25. Use the electrical diagram shown in Figure 16 to verify the connections.

NOTE
The converter is protected with a 15 amps fuse inside the box.

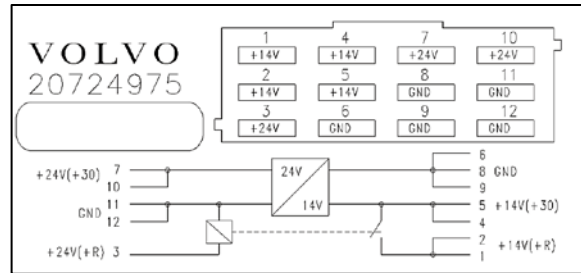

FIGURE 16

NOTE
For more information, refer to the Supplier section on the Technical Publications web site by clicking this link:
<https://techpub.prevostcar.com>
Search for "Volvo" as the supplier name.

26. Bulletin is complete for this vehicle.

ESTIMATED TIME: 1h00 of labour for part A installation and 30 minutes for part B installation.

PARTS / WASTE DISPOSAL

Discard waste according to applicable environmental regulations (Municipal/State[Prov.]/ Federal)