

CUSTOMER SATISFACTION CAMPAIGN 2A82 GSX250RL8 STARTER SWITCH

Affected Models: GSX250RL8

Affected Departments: Management, Service, Sales, Warranty, Parts, Accessories

Suzuki Motor of America, Inc. (Suzuki) is initiating a customer satisfaction campaign to replace the right handlebar switch assembly on certain 2018 GSX250R motorcycles.

Due to the structure of the starter switch in the right handlebar switch assembly, water can infiltrate the starter switch and cause a short circuit. If water remains on the electrical contacts of the starter switch, the engine may start automatically when turning the ignition key ON. The malfunction indicator light may also illuminate if the motorcycle continues to be ridden with this short circuit condition.

Affected Models	Model Year	VIN Range
GSX250R	2018	LC6DN11A*J1100008 – LC6DN11A*J1102374 <i>See Verification instructions below</i>

Verify if the right handlebar switch assembly needs to be replaced:

Only certain models with the VIN ranged listed above are affected. Before performing the campaign repair on a motorcycle, first verify that the repair needs to be performed by accessing the Vehicle Master Inquiry on Suzuki Connect and checking the repair status. If the repair needs to be performed, you will see the message “CAMPAIGN NOT YET PERFORMED.” If you have a question regarding motorcycle eligibility, contact your Suzuki Technical Service Manager (TSM) or call Tech-Line at (714) 996-7480.

What your dealership will do:

- 1) Replace the right handlebar switch assembly.
- 2) Submit a warranty claim immediately upon completion of the campaign repair.

What Suzuki will do:

During the week of March 26, 2018, Suzuki will mail notification letters to owners of affected motorcycles for whom we have information. The letter instructs the customer to contact a Suzuki dealer to schedule an appointment for the repair.

If you have sold an affected motorcycle to a customer prior to receiving this bulletin and have not made the repair, please contact the customer immediately to arrange for the motorcycle to be returned to your dealership for this repair.

Ordering parts for the campaign repair

- Parts are available now.
- Use the normal parts ordering procedure to order the parts kit(s) needed for units in your inventory or for customer units in your shop for service.
- If you have any questions about your parts order for this campaign, contact National Parts Coordination at (714) 854-2165.

PARTS ORDERING INFORMATION		
Parts Kits Name	Parts Kit Number	Qty.. Required
Switch Set, Handle	37200-20810-RX0	1

Warranty Claim Processing:

Submit a warranty claim for each campaign repair immediately upon completion. This campaign requires you to file a warranty claim using ONE of the methods described below.

Suzuki Connect Short Campaign Claim: A Short Campaign Claim will reimburse you for replacement of the right handlebar switch assembly and 1.0 hour labor.

CAMPAIGN 2A82 GSX250R STARTER SWITCH SUZUKI CONNECT SHORT FORM INSTRUCTIONS	
CLAIM INFORMATION	
CLAIM NUMBER:	XXXXX,X (Dealer enters number)
ENTRY TYPE (Dealer chooses):	VIN, Model/Frame or Control/Sequence # (Dealer chooses)
REPAIR DATE:	Enter date of repair
MILEAGE:	Enter mileage at repair date
CAMPAIGN NUMBER:	2A82

Suzuki Connect Long Campaign Claim: A Long Campaign Claim will reimburse you for replacement of the right handlebar switch assembly, 1.0 hour labor, and additional parts and labor as authorized by your TSM.

CAMPAIGN 2A82 GSX250R STARTER SWITCH SUZUKI CONNECT LONG FORM INSTRUCTIONS	
CLAIM INFORMATION	
CLAIM NUMBER:	XXXXX,X (Dealer enters number)
ENTRY TYPE:	VIN, Model/Frame or Control/Sequence # (Dealer chooses)
REPAIR DATE:	Enter date of repair
MILEAGE:	Enter mileage at repair date
CAMPAIGN NUMBER:	2A82
LABOR TIME (Choose one):	1.0 Hour or additional labor time as authorized by your TSM
PARTS INFORMATION	
REPLACEMENT PART:	37200-20810-RX0
ADDITIONAL PARTS:	Additional parts as authorized by your TSM
AUTHORIZATION:	Only needed if additional parts or labor claimed
FAILURE DESCRIPTION	
DESCRIPTION OF DEFECT:	Starter Switch Replacement
DESCRIPTION OF REPAIR	Performed campaign repair as required per Service Bulletin

WARRANTY INFORMATION

Model	Part Desc.	Part Number	Campaign Number
GSX250RL8	Switch Set, Handle	37200-20810-RX0	2A82

Repair Procedure:

Refer to the 2018 GSX250R Service Manual for the repair procedures listed below.

Remove the Right Handlebar Switch Assembly:

- 1) Remove the front seat. (Refer to 9D Seat Removal and Installation.)
- 2) Disconnect the battery (-) lead wire. (Refer to 1J Battery Removal and Installation.)
- 3) Remove the under center cowling. (Refer to 9D Under Center Cowling Removal and Installation.)
- 4) Remove the left and right side cowling assemblies and under cowling. (Refer to 9D Side Cowling / Inner Cowling / Under Cowling Removal and Installation.)
- 5) Remove the left and right frame side cover assemblies. (Refer to 9D Frame Side Front Cover / Frame Side Lower Cover / Frame Side Cover Removal and Installation.)
- 6) Remove the windscreen. (Refer to 9D Windscreen / Body Cowling / Meter Front Panel Removal and Installation.)
- 7) Remove the meter panel assembly. (Refer to 9D Meter Panel / Body Cowling Cover Removal and Installation.)
- 8) Disconnect the right handlebar switch coupler (1).

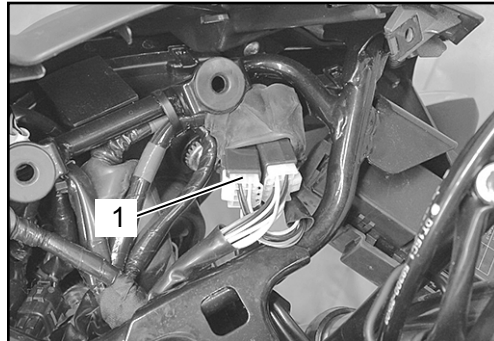

- 9) Remove clamps (1), (2) and (3).

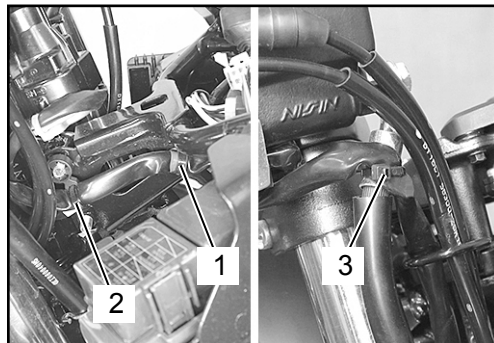

- 10) Disconnect the front brake light switch connectors (1).

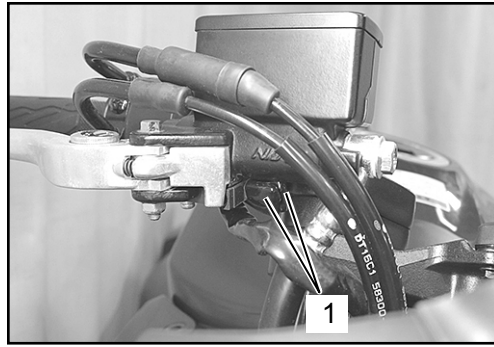

- 11) Relocate the rubber boot, exposing the adjuster (1).
12) Loosen the lock-nut (2), and turn the adjuster (3) to obtain free-play at the throttle.

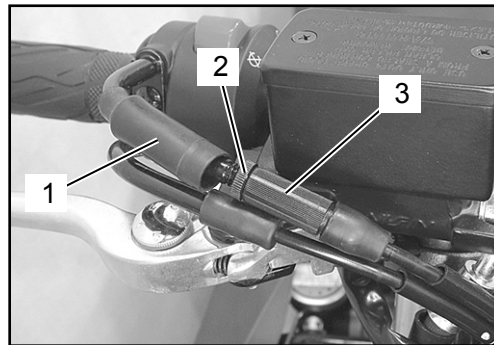

- 13) Remove the screw (1).

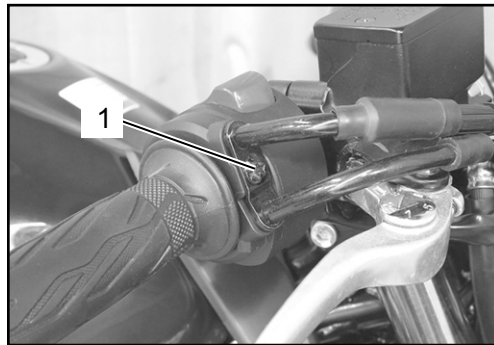

- 14) Remove the right handlebar switch assembly screws (1).

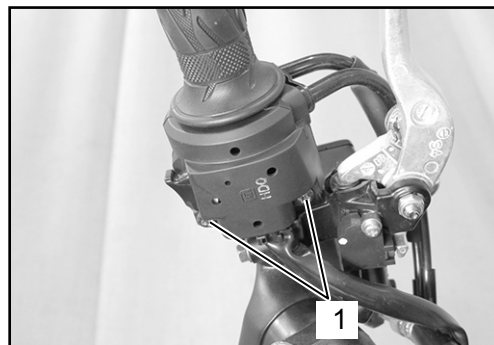

- 15) Remove the right handlebar switch assembly (3) by disconnecting the throttle cables (2) from the throttle grip (1).

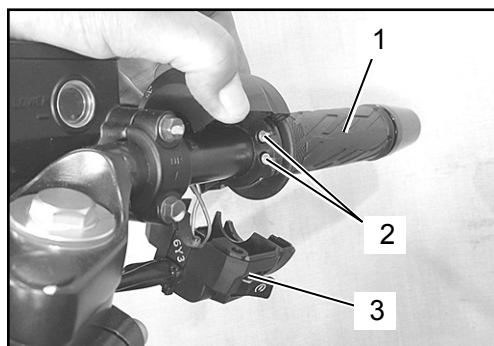

Install the Countermeasure Right Handlebar Switch Assembly:

- 1) Install the throttle cables through the right handlebar switch assembly and reconnect them to the throttle assembly.
- 2) Insert the projection (1) of the new right handlebar switch assembly into the hole (2) of the right handlebar, and tighten the right handlebar switch assembly screws.
- 3) Turn the throttle grip slowly and adjust the throttle cable play "a" at the periphery of the grip by turning the adjuster (1).

Throttle cable play [Standard]:
2.0 – 4.0 mm (0.079 – 0.16 in)

- 4) Tighten the lock-nut (2) while holding the adjuster (1).

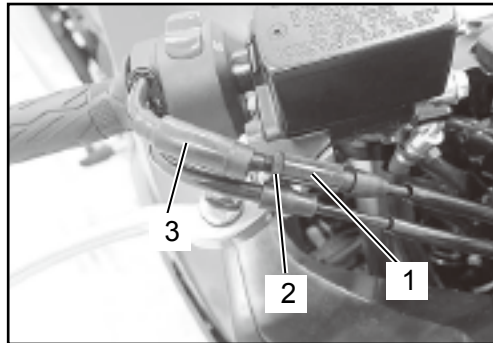
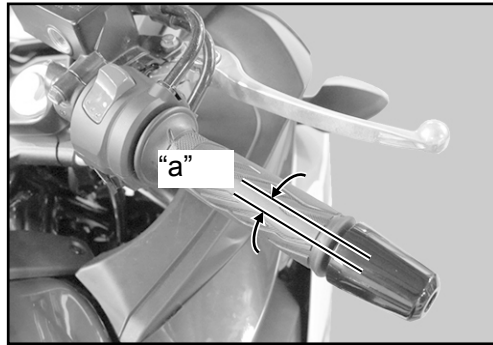
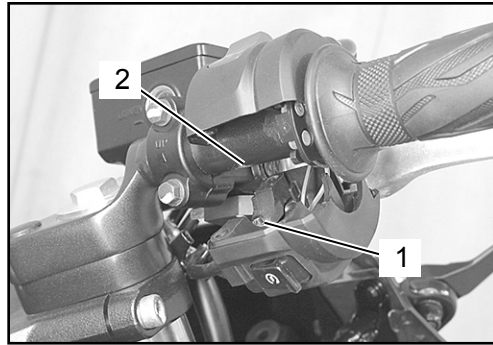

⚠ WARNING

Engine idle speed can rise if the throttle play is not adjusted correctly.

After the adjustment is complete, check that handlebar movement does not raise the engine idle speed and that the throttle grip returns smoothly and automatically.

- 5) Install the rubber boot (3).
- 6) Pass the right handlebar switch assembly lead wire as shown below.

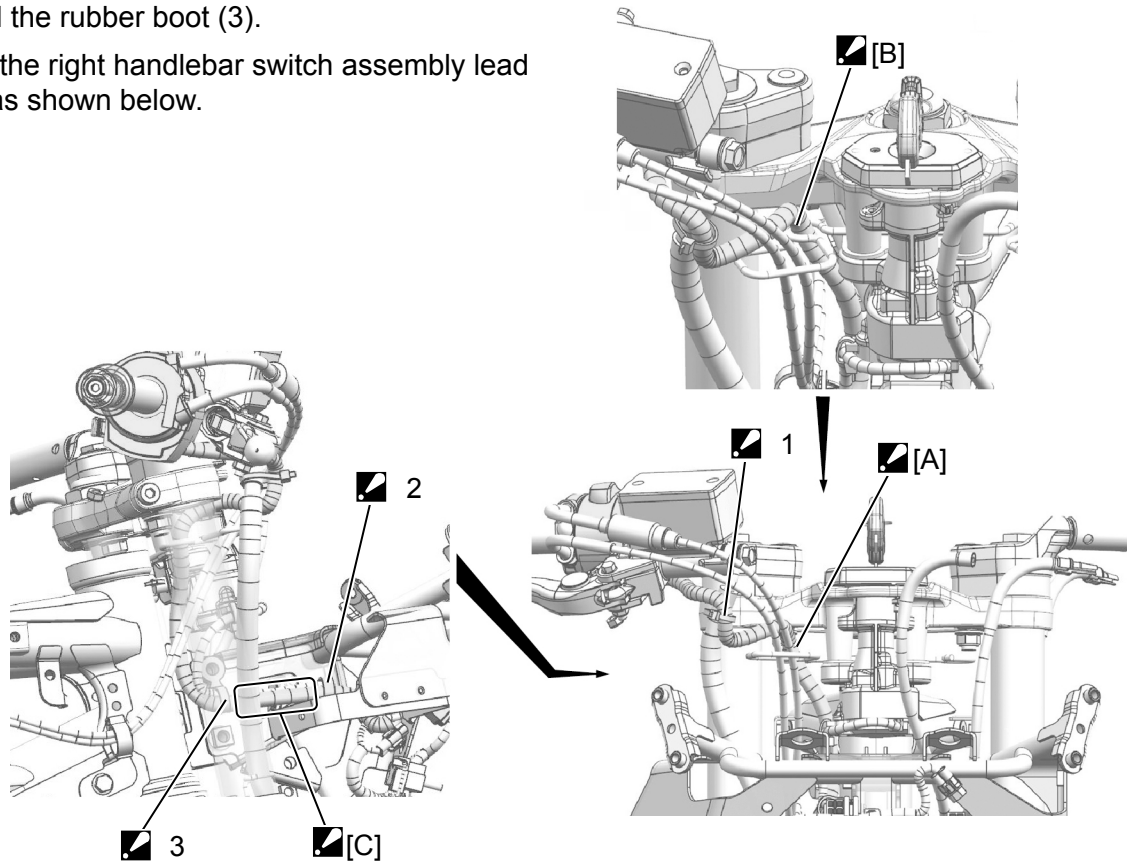

- [A] After passing the right handlebar switch assembly lead wire behind the throttle cables, fit the lead wire into the guide.
- [B] Fit the right handlebar switch assembly lead wire into the round shape part of the guide.
- [C] Be sure the switch assembly lead wire and ignition switch lead wires are adjusted to the same length between points 2 and 3 as illustrated above.
- 1. **Clamp P/N 09407-14407**
 Pass the right handlebar switch assembly lead wire in front of the front brake hose. Clamp the right handlebar switch assembly lead wire and brake hose sleeve. Point the locked part of clamp to right side, and cut off the tip of the clamp.
- 2. **Clamp P/N 09407-17403**
 Clamp the red tape position of the right handlebar switch assembly lead wire and ignition switch lead wire. Insert the clamp into the cowling brace hole, and cut off the tip of the clamp.
- 3. **Clamp P/N 36990-20K00**
 Clamp the white tape position of the ignition switch lead wire and right handlebar switch assembly lead wire. Cut off the tip of the clamp. After cutting the clamp, insert the clamp onto the rear side (upper side) of the cowling brace bolt.

- 7) Check that each part is properly installed and secured.
- 8) Check the performance of the right handlebar switch assembly.



SUZUKI MOTOR OF AMERICA, INC.

CUSTOMER SATISFACTION CAMPAIGN

This Notice Applies to Your Suzuki Vehicle Identification Number (VIN)

March 27, 2018

Dear Suzuki Owner:

Suzuki Motor of America, Inc. (Suzuki) has decided to implement a customer satisfaction campaign for certain 2018 GSX250R motorcycles. According to our records, you own one of the motorcycles affected by this customer satisfaction campaign.

What is the problem?

Due to the structure of the starter switch of the right handlebar switch assembly, water can infiltrate the starter switch and cause a short circuit. If water remains on the electrical contacts of the starter switch, the engine may start automatically when turning the ignition key ON. The malfunction indicator light may also illuminate if the motorcycle continues to be ridden with this short circuit condition.

What is Suzuki doing to solve the problem?

Your dealer will replace the right handlebar switch assembly. This procedure will take approximately one hour to complete. Parts are available now, and there will be no charge to you for this repair, parts and labor.

What you should do:

- Before taking your motorcycle to your dealer, contact them to set up an appointment for the repair.
- We suggest bringing this letter and the enclosed card to your dealer to help your dealer process your claim.

What to do if you receive this notice in error:

This notice was mailed to you according to the latest information that is available to us. If you no longer own the Suzuki motorcycle described in this notice, please complete and return the attached Change of Address/Ownership card to Suzuki Motor of America, Inc., and forward this information to the current owner (if known).

Who to contact if you experience problems:

Your Suzuki dealer can provide you the fastest response to your questions or concerns about this customer satisfaction campaign. If you have any difficulty with this service campaign repair, you may contact the Suzuki Motor of America, Inc., Customer Service Department for assistance at (714) 572-1490 during the hours of 7:00 AM to 4:30 PM Pacific Time. Please have your vehicle identification number (VIN) ready when calling.

If you need to locate your nearest Suzuki Motorcycle Dealer, please visit www.suzukicycles.com and click on the "FIND A DEALER" tab, which is located in the upper right corner of our website.

We apologize for any inconvenience this customer satisfaction campaign causes you. We hope you understand that your satisfaction is an important priority for us.

Sincerely,

Suzuki Motor of America, Inc.