

**\*\* TECHNICAL INFORMATION NOTICE \*\***

**DATE:** March 14, 2018  
**TO:** Mitsubishi Motors US & Puerto Rico Dealer Service and Parts Managers  
**RE:** Rear Park Assist Accessory on 2018 Eclipse Cross  
**TIN NO.** TIN-18-54-001

.....

**AFFECTED VEHICLES:** 2018 Eclipse Cross with Rear Park Assist accessory

**PURPOSE**

Some 2018 Eclipse Cross vehicles are equipped with a new Rear Park Assist accessory system that appears the same but functions differently than other (and previous) models.

The Eclipse Cross Rear Park Assist System features two (2) sensors located at the rear corners of the vehicle and two (2) sensors located in the center of the rear fascia. When the vehicle ignition switch is turned either to the “ACC” or “ON” position, the system will beep once and the corner sensors are activated (corner mode). The corner sensors remain active until the vehicle speed exceeds approximately 12 mph (20 km/hr) and will automatically re-activate when the vehicle speed drops to about 6 mph (10 km/hr). While the corner sensors are active, and an obstacle is detected within approximately 14 inches (35 cm), the system will sound an alert. When the ignition switch is in the “ON” position, and selector lever is moved to “R” (Reverse), then all rear sensors are activated. This is the full rear park assist mode (back sensors along with the rear corner sensors).

Either mode can be toggled on and off (silent mode) by pressing the Park Assist switch located on the driver’s side dash panel one time.

**NOTE: When the vehicle is too close to an obstacle (less than 14 inches / 35 cm), the buzzer may not sound, or it may change from a continuous sound to an intermittent sound.**

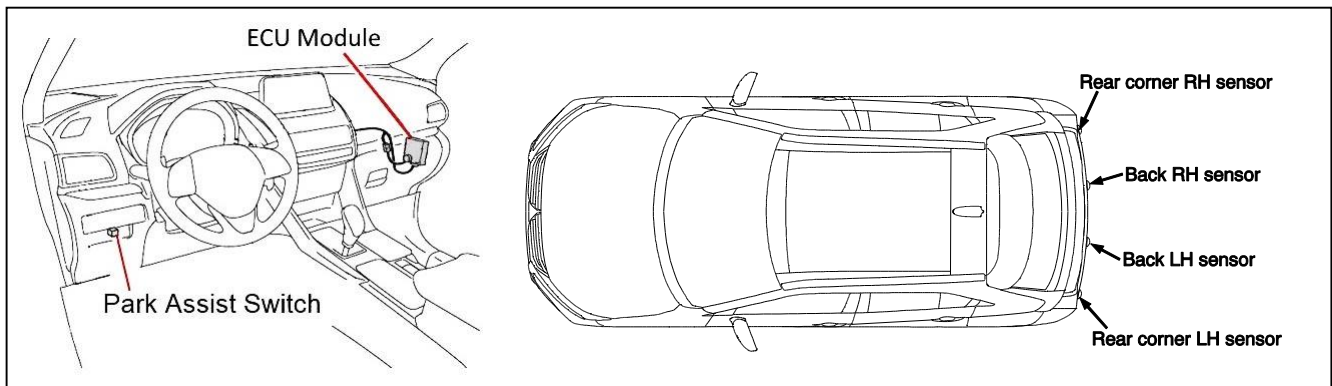

For vehicles equipped with a tow hitch, there is also a towing mode that modifies the detection area to accommodate the use of a ball type hitch.

To engage the towing mode:

- 1) Turn the ignition switch to “ON”
- 2) Press brake pedal and place the shift lever into the “R” position
- 3) Press the Park Assist switch once (entering silent mode)
- 4) Press and hold the Park Assist switch a second time until (2) beeps are heard (towing mode)

The system will remain in towing mode until steps 1-4 are repeated again.

**NOTE:** At step 4 only a single beep will indicate the return to normal operation mode.

While in towing mode the system audible alerts can be toggled on and off by a single push of the park assist control switch.

For additional details on system features, operation, and cautions, please refer to the customer Owner's Manual for Park Sensor ECU Kit (p/n MZ360727EX) that was shipped inside the vehicle. The Owner's Manual can also be found in CAPS (under Accessory).