

TECHNICAL INSTRUCTIONS
FOR
LIMITED SERVICE CAMPAIGN FOR
3RD ROW SEAT BACK PANEL REPLACEMENT
CERTAIN 2011 MODEL YEAR SIENNA

The repair quality of covered vehicles is extremely important to Toyota. All dealership associates involved in the product update process are required to successfully complete E-Learning course SC13A. To ensure that all vehicles have the update performed correctly; technicians performing this product update are required to currently hold at least one of the following certification levels:

- **Certified any specialty**
- **Expert any specialty**
- **Master**
- **Master Diagnostic Technician**

I. OPERATION FLOW CHART

The flow chart is for reference only. **DO NOT** use it in place of the full technical instructions. Follow **ALL** steps as outlined in the full technical instructions to confirm the campaign is completed correctly.

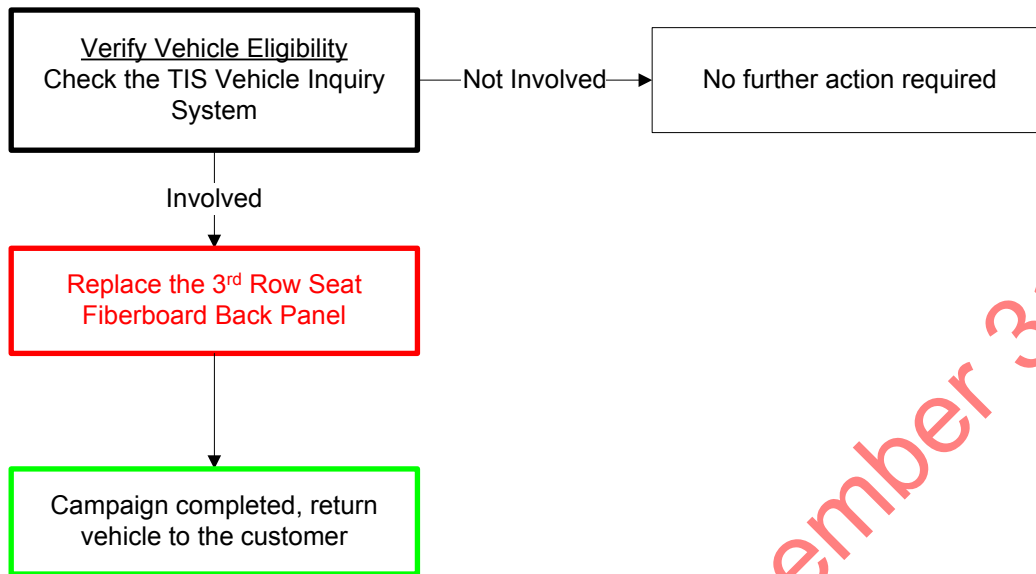

II. IDENTIFICATION OF AFFECTED VEHICLES

- Check the TIS Vehicle Inquiry System to confirm the VIN is involved in this Safety Recall, and that the campaign has not already been completed prior to dealer shipment or by another dealer.
- TMS warranty will not reimburse dealers for repairs conducted on vehicles that are not affected or were completed by another dealer.

III. BACKGROUND

The 3rd row seat back panel contains instructions on how to stow and use the 3rd row seats. If the proper steps are not followed, users may have difficulty properly stowing or using the seats. Toyota has developed a new 3rd row seat fiberboard back panel containing larger labeling and sequenced instructions

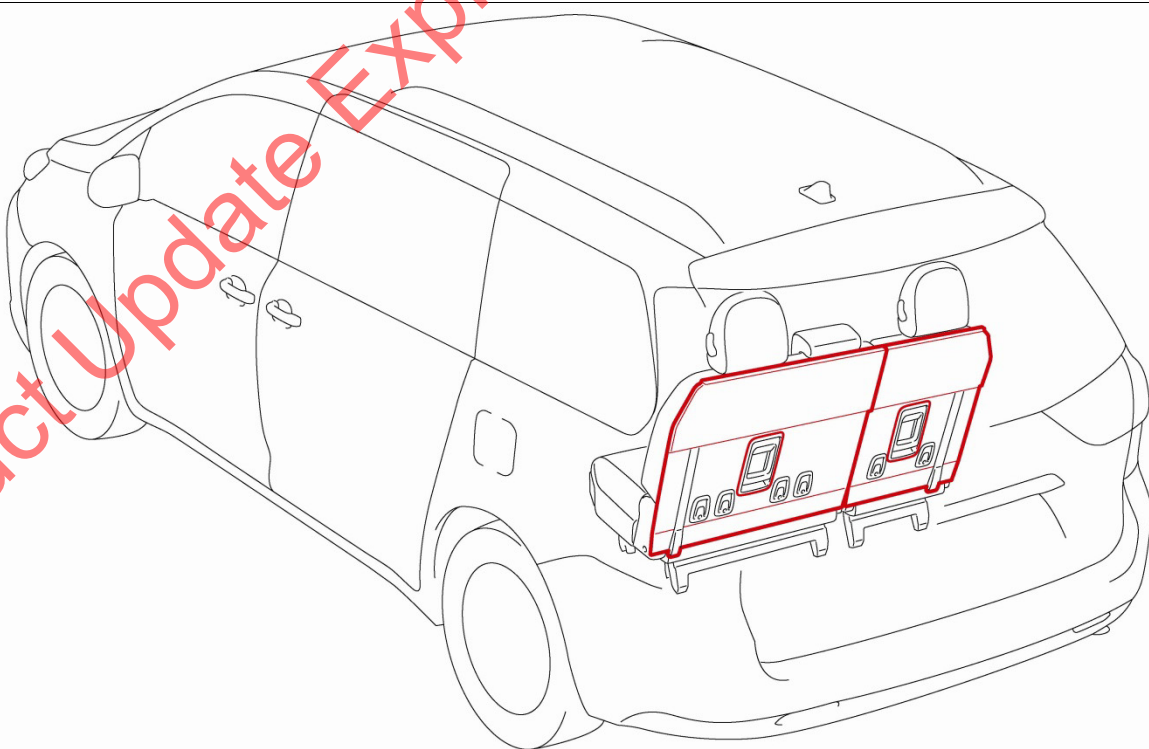

IV. PREPARATION

A. PARTS

Part Number	Part Description	Color	Quantity
04004-09108-B0	Cover Kit, RR Seat Back Board, RH & LH	Dark Gray	1
04004-09108-B1	Cover Kit, RR Seat Back Board, RH & LH	Gray	1
04004-09108-E0	Cover Kit, RR Seat Back Board, RH & LH	Ash Brown	1

B. TOOLS & EQUIPMENT

- Standard hand tools

C. MATERIALS

- Standard hand tools
- Protective Gloves

V. COMPONENTS

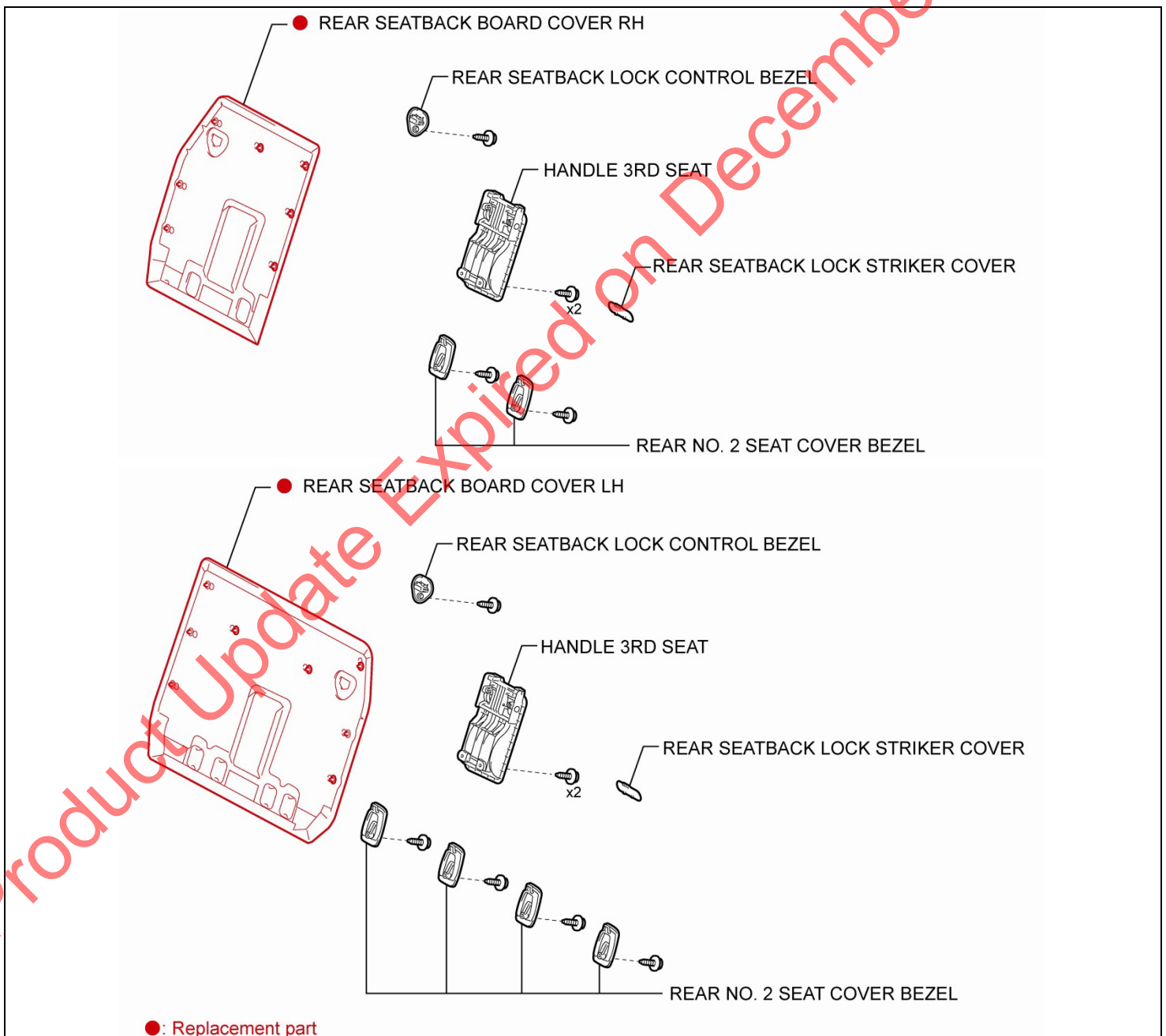

VI. 3RD ROW SEATBACK BOARD REMOVAL PROCEDURE

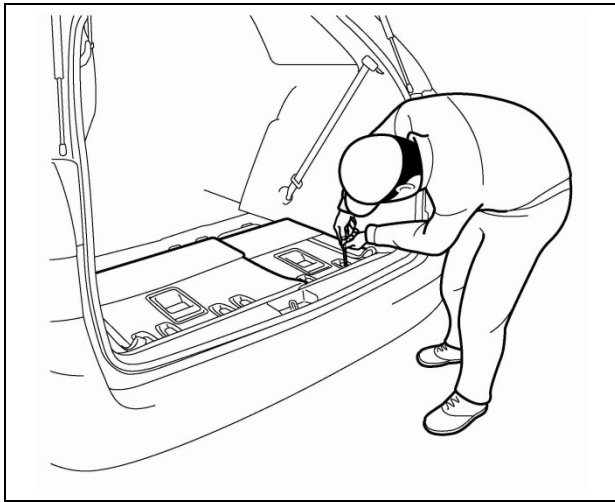

1. FOLD/STOW 3RD ROW SEATS

- a) If the seats are not stowed, stow the seats in the stored position as shown.

NOTE: If this is not possible due customer cargo the procedure can be done in the upright position.

STOP

The seats do not need to be removed to perform this procedure.

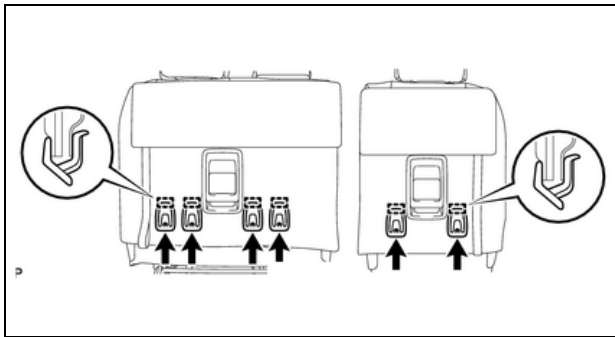

2. REMOVE THE SEAT BEZELS FROM THE LH & RH SEAT BACK

- a) Remove the 6 screws from the seat bezel (1 screw per bezel).
- b) Disengage the guide and remove all 6 bezels.

STOP

Wear protective gloves so that your hands do not get injured from the sharp edges of the parts.

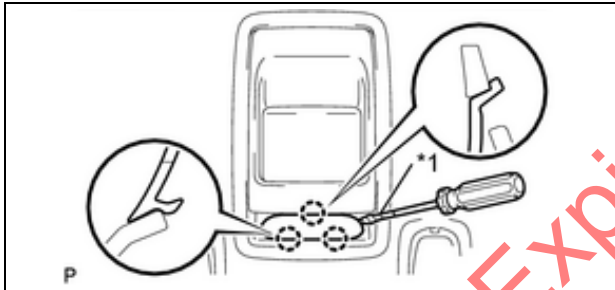

3. REMOVE THE REAR SEATBACK LOCK STRIKER COVER LH & RH

- a) Using a plastic pry tool or screw driver wrapped in protective taper, disengage the the 3 claws on each cover.

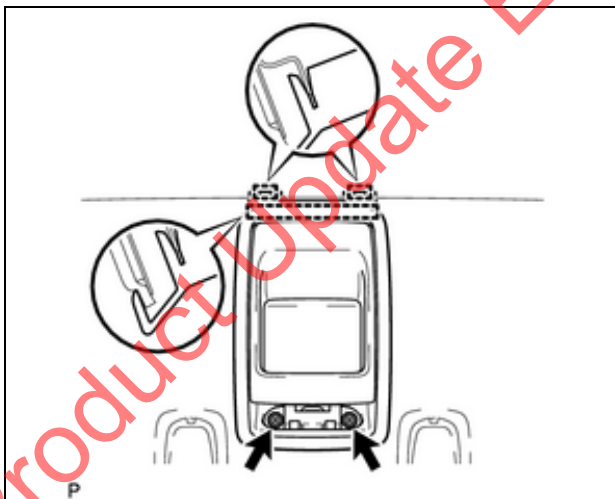

4. REMOVE THE SEATBACK HANDLE LH & RH

- a) Remove the 2 screws from each handle.
- b) Disengage the 3 guides for each seat handle.

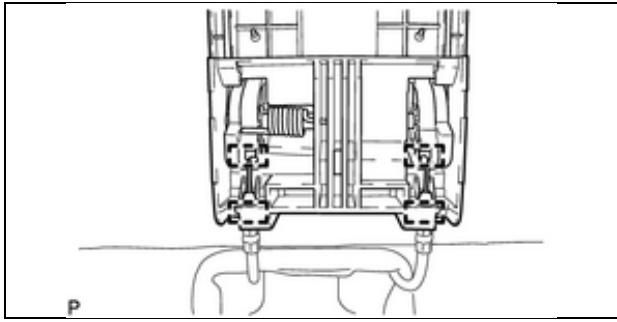

- c) Disconnect the 4 cable clamps on each handle..

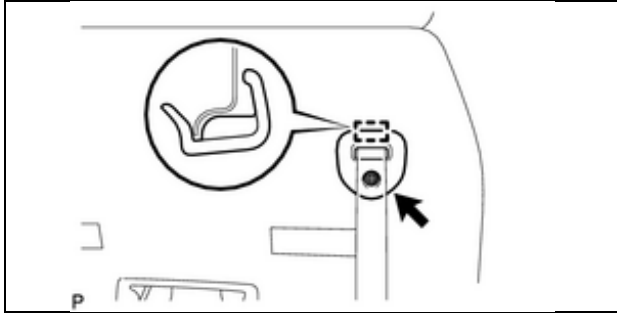

5. REMOVE THE SEAT BACK LOCK CONTROL BEZEL LH & RH

- a) Remove the screw.
- b) Disengage the guide and remove the bezel.
- c) Repeat on the steps on the other seat.

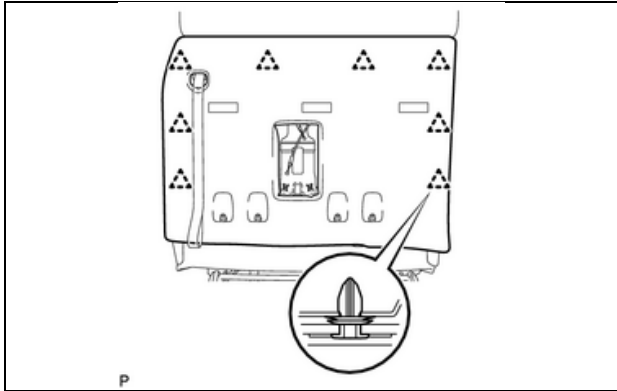

6. REMOVE THE LH SIDE SEATBACK BOARD

- a) Disengage the 8 clips and remove the seatback board.

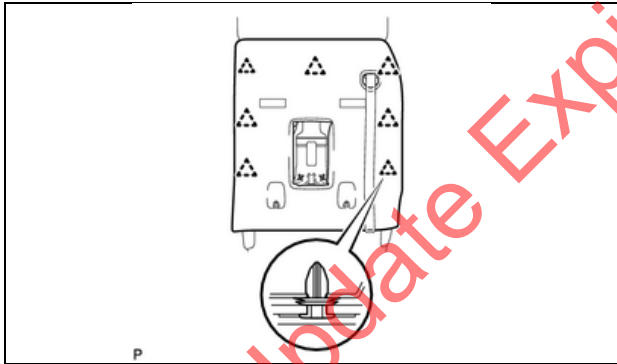

7. REMOVE THE RH SEATBACK BOARD

- a) Disengage the 7 clips and remove the seatback board.

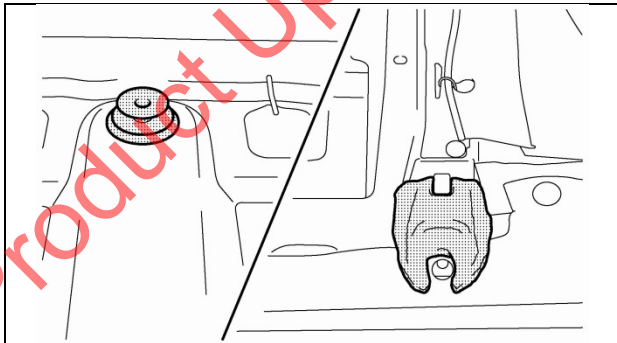

8. CONFIRM REMOVAL

- a) Confirm all the old clips have been removed.
- b) Confirm that there are no remaining pieces of the seatback board on the seat assembly.

9. MARK THE OLD SEATBACK BOARD SO THAT THEY ARE NOT REUSED

VII. SEATBACK BOARD INSTALLATION PROCEDURE

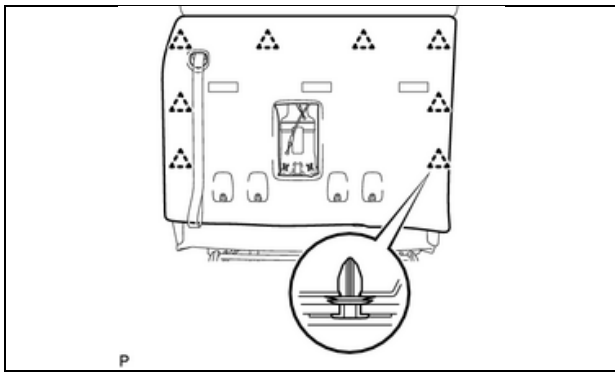

1. INSTALL THE NEW LH SEATBACK BOARD

- a) Engage the 8 seatback board clips.

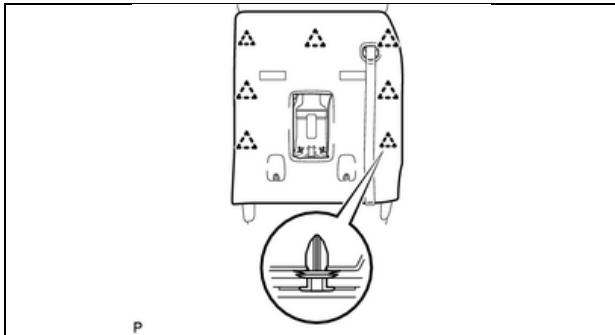

2. INSTALL THE NEW RH SEATBACK BOARD

- a) Engage the 7 seatback board clips.

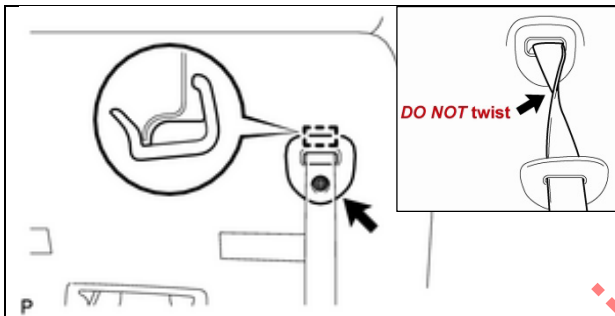

3. INSTALL SEATBACK LOCK CONTROL BEZEL

- a) Engage the guide.
- b) Install the screw on the bezel.
- c) Repeat steps on other seat.

NOTE: Ensure that the No.1 reclining release handle is not twisted when installing the lock control bezel.

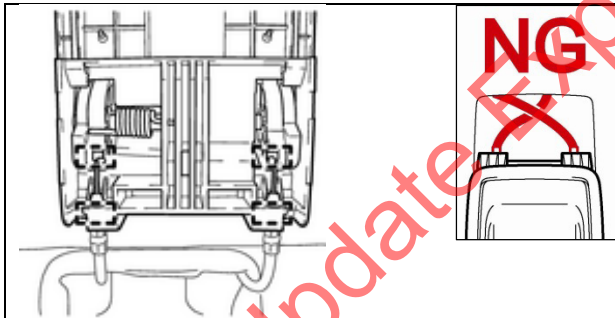

4. INSTALL THE SEATBACK HANDLE

- a) Connect the the 4 cable clamps on each handle.

NOTE: Ensure that the cables are not crossed when installing the handle.

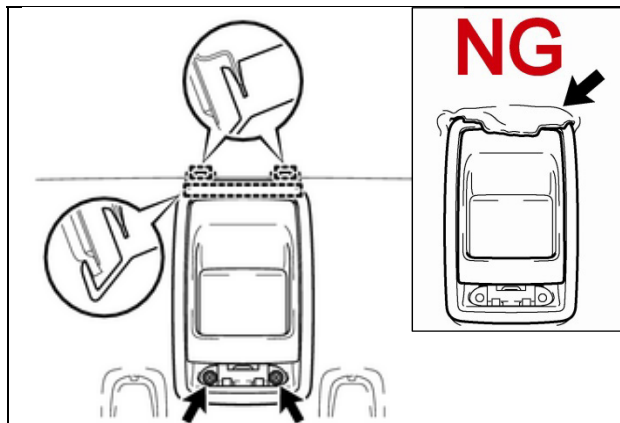

b) Engage the 3 guides and install the 2 screws on each handle.

NOTE: Ensure that the carpet is positioned properly under the handle.

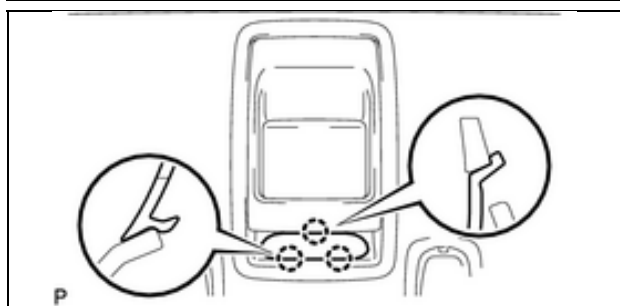

5. INSTALL THE SEATBACK STRIKER COVER

a) Engage the 3 claws and install the striker on each seat.

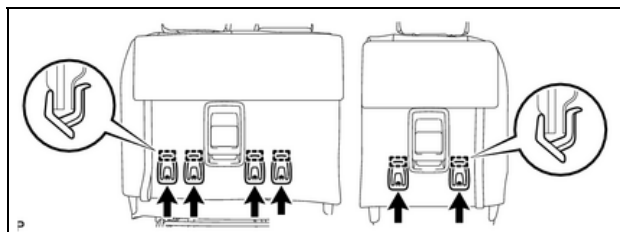

6. INSTALL THE SEATBACK BEZELS

a) Engage the guide on install the screw on each of the 6 bezels.

7. RETURN SEAT TO THE CUSTOMER'S ORIGINAL POSITION.

◀ VERIFY REPAIR QUALITY ▶

- Confirm the correct seatback covers have been installed.
- Confirm the 3rd row seat functions properly.
- Confirm that the seat is clean and free of debris.

If you have any questions regarding this update, please contact your area representative.

VIII. APPENDIX

A. CAMPAIGN DESIGNATION DECODER

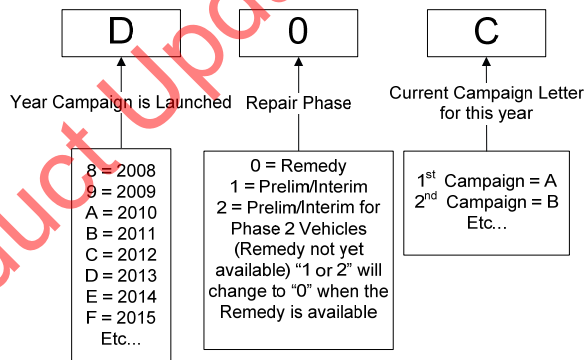

B. CAMPAIGN PARTS DISPOSAL

As required by Federal Regulations, please make sure all campaign parts (original parts) removed from the vehicle are disposed of in a manner in which they will not be reused, **unless requested for parts recovery return.**