

MODEL: Karma Revero**DATE:** June 2017**TITLE:** Interior Rear View Mirror Vibration Remedy**Revised:** February 2018**PRIORITY:** On Complaint**APPLICABILITY:** MY17 and MY18 Revero**MARKET REGION:** North America**PURPOSE:** Interior Rear view mirror may have a vibration at certain frequency, bulletin procedure remedies this for affected vehicles.

Prepare the vehicle for the procedure.

Cover the dash securely with a plastic sheet or a blanket to prevent any material coming in contact or staining the interior. (fig.1)



fig.1

Karma Automotive Bulletins and service documents are intended for use by experienced and trained Technicians. If you lack the skills, tools, equipment and a suitable workshop for any procedure described in this document, we suggest you leave such repairs to a Karma retailer and service provider. See your service provider for advice on whether your vehicle may benefit from the information contained within this document. The information contained in the Karma Bulletin is accurate at the date of publication. However, Karma Automotive regularly updates technical information. Please check with your Karma Automotive Retailer and Karma Automotive service provider that the bulletin you intend to use contains the latest available information.

MODEL: Karma Revero**DATE: June 2017****TITLE: Interior Rear View Mirror Vibration Remedy****Revised: February 2018**

The following equipment must be ready for the procedure:

- Torx Screw driver #20
- Masking tape
- Adhesive - Teroson - Teromix PU6700 with applicator tip (in service kit C161171100100)
- Dispenser tool (also from the service kit)
- Razor blade
- Latex or nitrile gloves
- Torque wrench



Karma Automotive Bulletins and service documents are intended for use by experienced and trained Technicians. If you lack the skills, tools, equipment and a suitable workshop for any procedure described in this document, we suggest you leave such repairs to a Karma retailer and service provider. See your service provider for advice on whether your vehicle may benefit from the information contained within this document. The information contained in the Karma Bulletin is accurate at the date of publication. However, Karma Automotive regularly updates technical information. Please check with your Karma Automotive Retailer and Karma Automotive service provider that the bulletin you intend to use contains the latest available information.

MODEL: Karma Revero**DATE: June 2017****TITLE: Interior Rear View Mirror Vibration Remedy****Revised: February 2018**

Prepare the applicator

The plunger needs to be 1:1 ratio

Insert the adhesive tub with the label up as shown

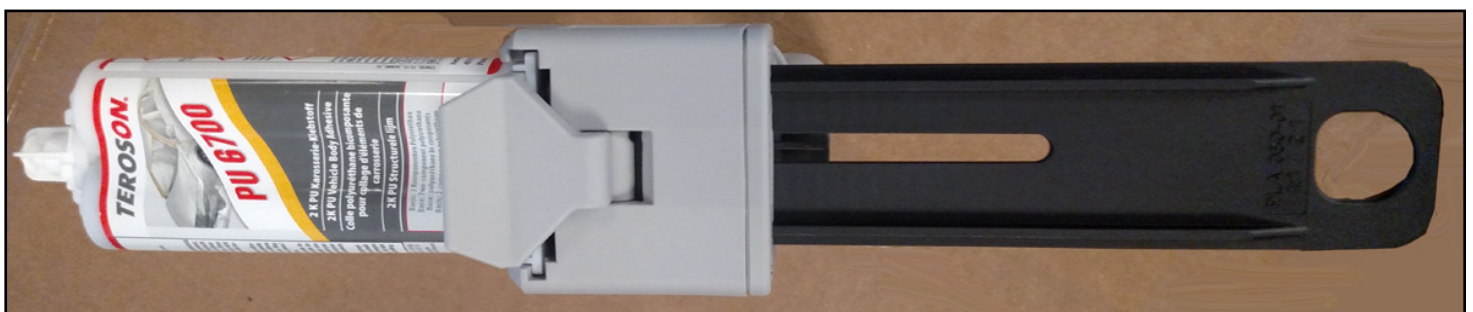

Karma Automotive Bulletins and service documents are intended for use by experienced and trained Technicians. If you lack the skills, tools, equipment and a suitable workshop for any procedure described in this document, we suggest you leave such repairs to a Karma retailer and service provider. See your service provider for advice on whether your vehicle may benefit from the information contained within this document. The information contained in the Karma Bulletin is accurate at the date of publication. However, Karma Automotive regularly updates technical information. Please check with your Karma Automotive Retailer and Karma Automotive service provider that the bulletin you intend to use contains the latest available information.

MODEL: Karma Revero

DATE: June 2017

TITLE: Interior Rear View Mirror Vibration Remedy

Revised: February 2018

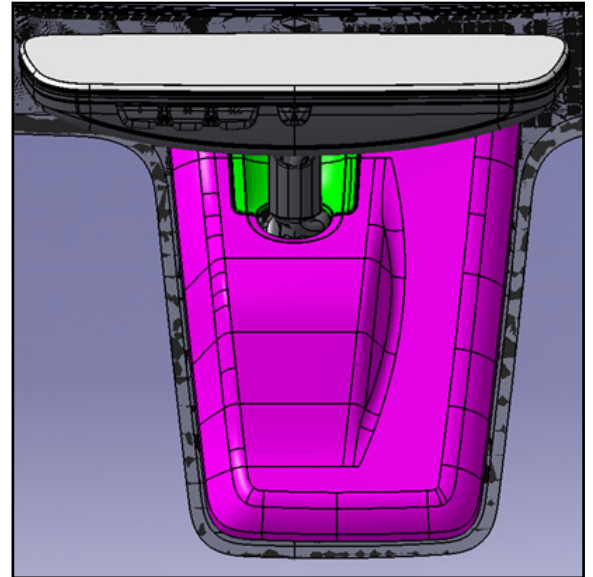

Remove the ADAS camera bezel, there are two parts.

1) The shroud behind the mirror stem (green), this pops off by applying small pressure to the base near the stem. (fig.2a and fig.2b)



fig.2a



fig.2b

Karma Automotive Bulletins and service documents are intended for use by experienced and trained Technicians. If you lack the skills, tools, equipment and a suitable workshop for any procedure described in this document, we suggest you leave such repairs to a Karma retailer and service provider. See your service provider for advice on whether your vehicle may benefit from the information contained within this document. The information contained in the Karma Bulletin is accurate at the date of publication. However, Karma Automotive regularly updates technical information. Please check with your Karma Automotive Retailer and Karma Automotive service provider that the bulletin you intend to use contains the latest available information.

MODEL: Karma Revero

DATE: June 2017

Revised: February 2018

TITLE: Interior Rear View Mirror Vibration Remedy

2) Remove ADAS bezel cover (shown in pink for clarity, fig 3a). This will expose a screw that is used to mount the rear view mirror onto the rear view mirror puck (fig 3b). Unscrew the mirror from the puck by sliding it rearward.

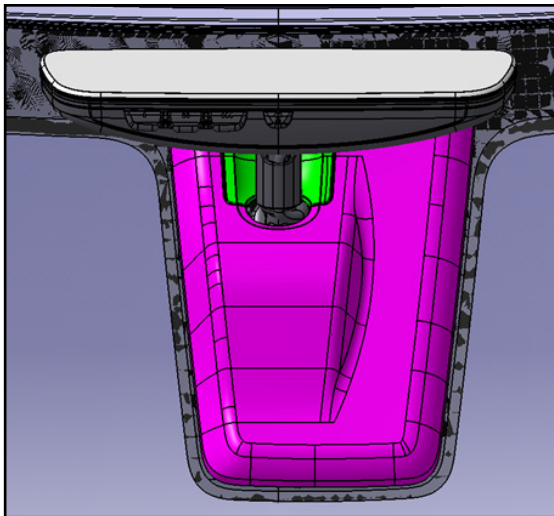

fig.3a

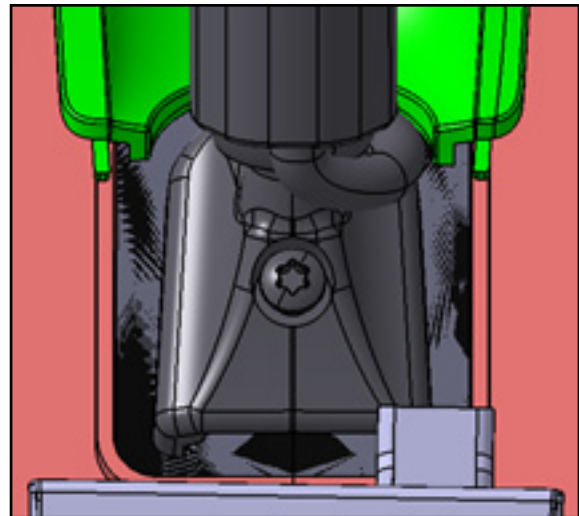

fig.3b

Be careful as the bezel (fig.4a and fig.4b) is trapped by the mirror, and when the mirror is removed it is tethered by the connector in the headliner. An assistant may be useful to keep this out of the way during adhesive application.



fig.4a



fig.4b

Karma Automotive Bulletins and service documents are intended for use by experienced and trained Technicians. If you lack the skills, tools, equipment and a suitable workshop for any procedure described in this document, we suggest you leave such repairs to a Karma retailer and service provider. See your service provider for advice on whether your vehicle may benefit from the information contained within this document. The information contained in the Karma Bulletin is accurate at the date of publication. However, Karma Automotive regularly updates technical information. Please check with your Karma Automotive Retailer and Karma Automotive service provider that the bulletin you intend to use contains the latest available information.

MODEL: Karma Revero

DATE: June 2017

Revised: February 2018

TITLE: Interior Rear View Mirror Vibration Remedy

3) Disconnect the ADAS camera connector (fig. 5a and fig. 5b).
Tape this off to avoid adhesive contamination (fig5c)



fig.5a



fig.5b



fig.5c

Karma Automotive Bulletins and service documents are intended for use by experienced and trained Technicians. If you lack the skills, tools, equipment and a suitable workshop for any procedure described in this document, we suggest you leave such repairs to a Karma retailer and service provider. See your service provider for advice on whether your vehicle may benefit from the information contained within this document. The information contained in the Karma Bulletin is accurate at the date of publication. However, Karma Automotive regularly updates technical information. Please check with your Karma Automotive Retailer and Karma Automotive service provider that the bulletin you intend to use contains the latest available information.

MODEL: Karma Revero

DATE: June 2017

TITLE: Interior Rear View Mirror Vibration Remedy

Revised: February 2018

4) Tape off the mirror puck as indicated in (fig.6a and fig.6b) Blue masking tape is illustrated here.

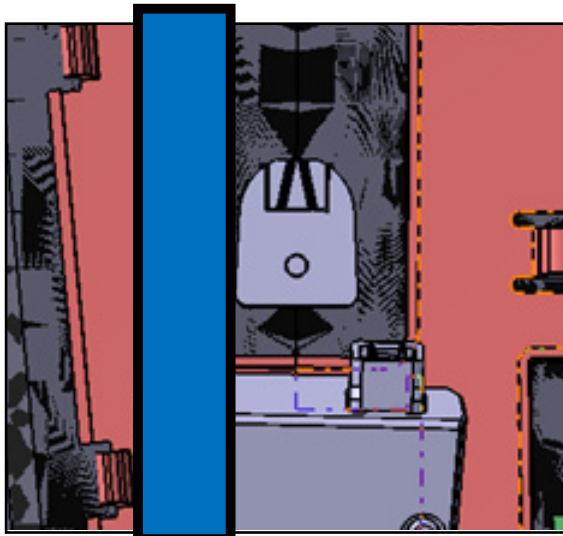

fig.6a

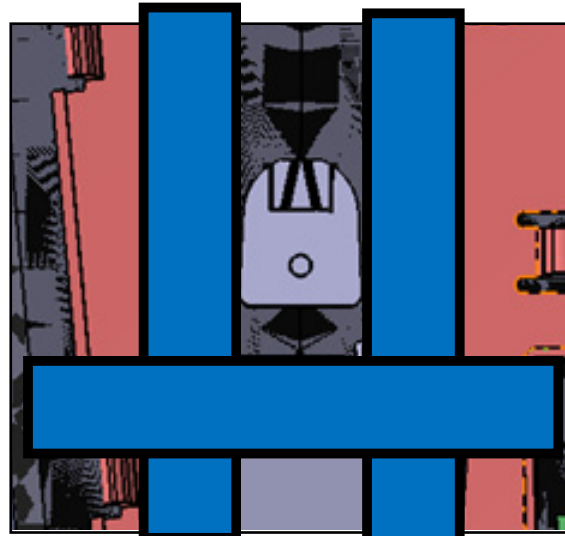

fig.6b

The unmasked area will be filled with adhesive as indicated in (fig.6c)

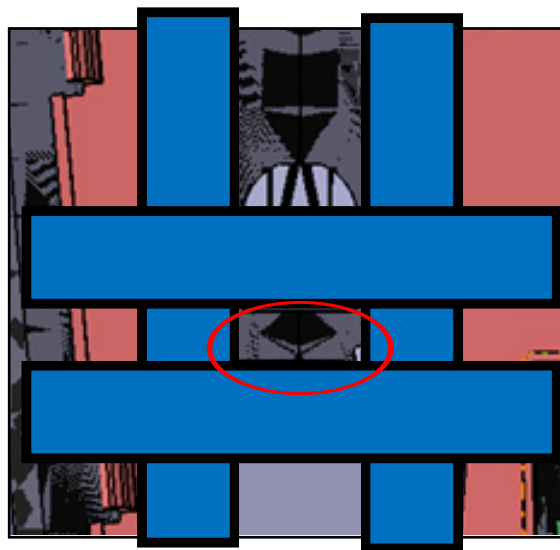

fig.6c

Karma Automotive Bulletins and service documents are intended for use by experienced and trained Technicians. If you lack the skills, tools, equipment and a suitable workshop for any procedure described in this document, we suggest you leave such repairs to a Karma retailer and service provider. See your service provider for advice on whether your vehicle may benefit from the information contained within this document. The information contained in the Karma Bulletin is accurate at the date of publication. However, Karma Automotive regularly updates technical information. Please check with your Karma Automotive Retailer and Karma Automotive service provider that the bulletin you intend to use contains the latest available information.

MODEL: Karma Revero**DATE: June 2017****Revised: February 2018****TITLE: Interior Rear View Mirror Vibration Remedy**

5) After taping is complete (fig.7a) Prepare the applicator and use a 1:1 plunger provided. Begin adhesive application (fig.7b) by filling the prescribed area beginning at the glass painted surface, layering the adhesive until it is flush with the mirror puck. (fig.7c with tape removed for clarity). Adhesive should reach the base of the mirror puck as shown (fig.7d with tape removed for clarity).

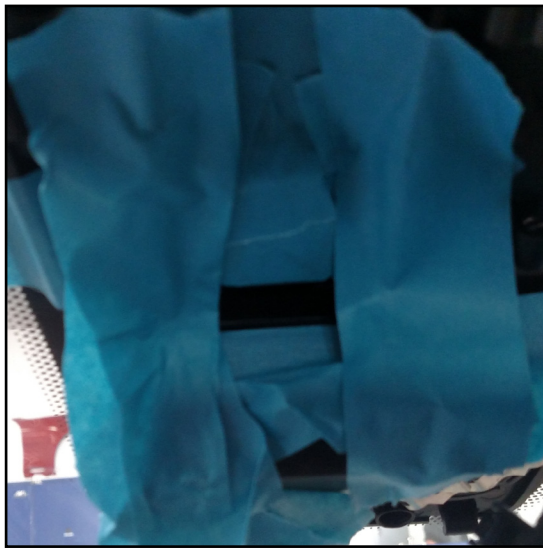

fig.7a



fig.7b



fig.7c

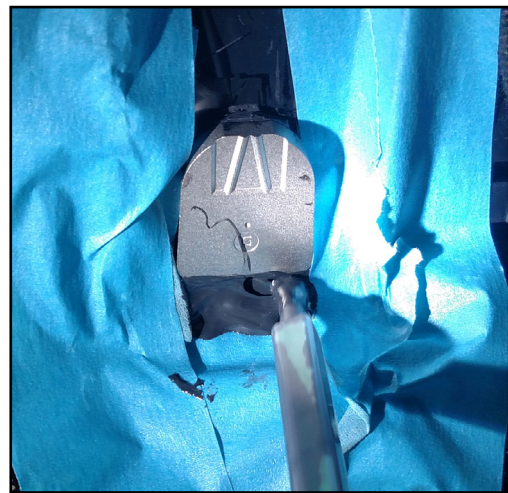

fig.7D

Karma Automotive Bulletins and service documents are intended for use by experienced and trained Technicians. If you lack the skills, tools, equipment and a suitable workshop for any procedure described in this document, we suggest you leave such repairs to a Karma retailer and service provider. See your service provider for advice on whether your vehicle may benefit from the information contained within this document. The information contained in the Karma Bulletin is accurate at the date of publication. However, Karma Automotive regularly updates technical information. Please check with your Karma Automotive Retailer and Karma Automotive service provider that the bulletin you intend to use contains the latest available information.

MODEL: Karma Revero

DATE: June 2017

Revised: February 2018

TITLE: Interior Rear View Mirror Vibration Remedy

NOTE: Adhesive will begin to harden in minutes. It will set in two hours and fully cure in 24 hours. Removal of tape should be done after ten minutes but no later than 15 minutes, any adhesive should be cleaned off immediately.

6) Smooth off the applied adhesive with a razor while still taped (fig. 8a). Remove the tape no sooner than ten minutes and no later than 15 minutes to allow the adhesive to set and cure (fig. 8b). The adhesive **MUST** be flush with the puck and under no circumstances be higher (over-flush) than or pass the edges of the puck (LH and RH), as this will not allow the mirror to mount properly.



fig.8a



fig.8b

Karma Automotive Bulletins and service documents are intended for use by experienced and trained Technicians. If you lack the skills, tools, equipment and a suitable workshop for any procedure described in this document, we suggest you leave such repairs to a Karma retailer and service provider. See your service provider for advice on whether your vehicle may benefit from the information contained within this document. The information contained in the Karma Bulletin is accurate at the date of publication. However, Karma Automotive regularly updates technical information. Please check with your Karma Automotive Retailer and Karma Automotive service provider that the bulletin you intend to use contains the latest available information.

MODEL: Karma Revero**DATE: June 2017****TITLE: Interior Rear View Mirror Vibration Remedy****Revised: February 2018**

7) After curing, reassemble the mirror. (fig.9) Torque for set screw is 2.7 Nm (2.5 +/- 0.3Nm)

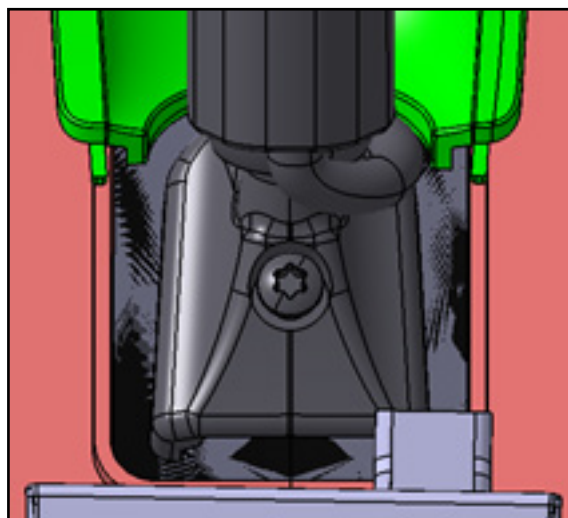

fig.9

Karma Automotive Bulletins and service documents are intended for use by experienced and trained Technicians. If you lack the skills, tools, equipment and a suitable workshop for any procedure described in this document, we suggest you leave such repairs to a Karma retailer and service provider. See your service provider for advice on whether your vehicle may benefit from the information contained within this document. The information contained in the Karma Bulletin is accurate at the date of publication. However, Karma Automotive regularly updates technical information. Please check with your Karma Automotive Retailer and Karma Automotive service provider that the bulletin you intend to use contains the latest available information.



Technical Service Bulletin

TB-17-82-10

MODEL: Karma Revero

DATE: June 2017

Revised: February 2018

TITLE: Interior Rear View Mirror Vibration Remedy

PARTS REQUIRED:

PART NUMBER	DESCRIPTION
N/A	N/A

SHOP SUPPLIES:

DESCRIPTION
N/A

SPECIAL TOOLS:

PART NUMBER	DESCRIPTION
C161171100100	Service Kit – Adhesive and Applicator

CAUSAL PART:

PART NUMBER	DESCRIPTION
C131166800100	Interior Rear view Mirror

LABOR CODES:

CODE	DESCRIPTION	TIME	DEFECT CODE
76-10-02-10	TB-17-812-10 Mirror Vibration Remedy	0.6	76-10-02-27

SUBLET:

CODE	DESCRIPTION	AMOUNT
N/A		

WARRANTY DISPOSITION: This repair is covered under the New Vehicle Limited Warranty, in effect for five (5) years from the in-service date with no mileage limitation.

Karma Automotive Bulletins and service documents are intended for use by experienced and trained Technicians. If you lack the skills, tools, equipment and a suitable workshop for any procedure described in this document, we suggest you leave such repairs to a Karma retailer and service provider. See your service provider for advice on whether your vehicle may benefit from the information contained within this document. The information contained in the Karma Bulletin is accurate at the date of publication. However, Karma Automotive regularly updates technical information. Please check with your Karma Automotive Retailer and Karma Automotive service provider that the bulletin you intend to use contains the latest available information.