

MODEL: Karma Revero**DATE:** February 2018**TITLE:** Brake Squeak Remedy**First Release****PRIORITY:** On Complaint**APPLICABILITY:** MY17 and MY18 Revero**MARKET REGION:** North America**PURPOSE:** To remedy complaint of brake squeak or squeal**Overview:**

Any vehicle with squeaky brake concerns from the front or rear brakes, with pads that are at 90% or less worn should have the brake pads and rotors cleaned with the appropriate brake clean solution, and have the shims replaced and grease reapplied.

The noise is most noticeable at slow speeds such as when pulling into or reversing out of a parking spot and can be further aggravated in cold or damp weather.

Standard service procedure involves applying the provided brake paste from the Karma brake lining service kit, to certain areas of the brake pad back side.

C161125100300: Kit - Shim and Grease - Front (fig. 1a)

C161125200300: Kit - Shim and Grease - Rear (fig. 1b)



fig. 1a



fig. 1b

Karma Automotive Bulletins and service documents are intended for use by experienced and trained Technicians. If you lack the skills, tools, equipment and a suitable workshop for any procedure described in this document, we suggest you leave such repairs to a Karma retailer and service provider. See your service provider for advice on whether your vehicle may benefit from the information contained within this document. The information contained in the Karma Bulletin is accurate at the date of publication. However, Karma Automotive regularly updates technical information. Please check with your Karma Automotive Retailer and Karma Automotive service provider that the bulletin you intend to use contains the latest available information.

MODEL: Karma Revero**DATE: February 2018****TITLE: Brake Squeak Remedy****First Release**

Follow the service manual for the removal of rims and brake calipers to access the pads if required (fig 2a,2b).

Remove and Inspect Front Brake Pads

Remove and Inspect Rear Brake Pads

To remove the front brake pads see the service manual for the procedure in: Brakes- Brake Pads- Front (and Rear as applicable) .

Inspect the brake pads and rotors for any type of unusual wear or embedded debris.

Verify that all retaining clips and pins are present and are not damaged or loose. Thoroughly clean the brake pads using a suitable cleaner and replace any missing or worn parts

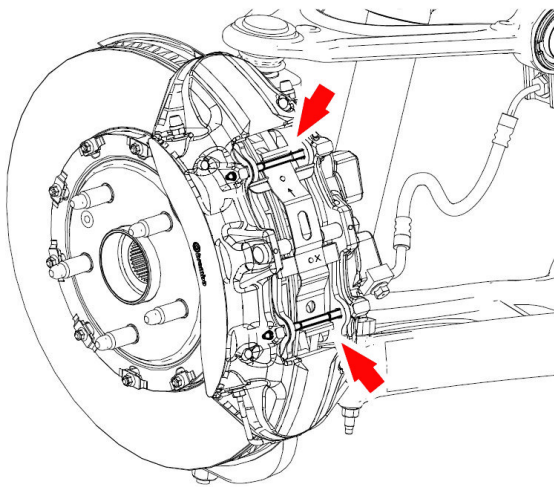

fig 2a

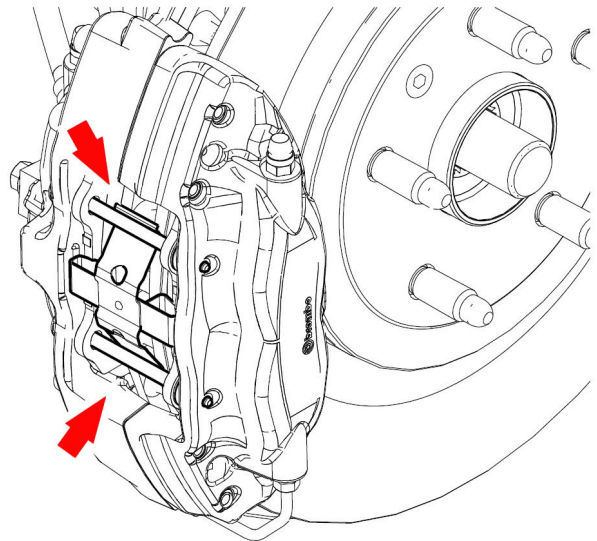

fig 2b

Karma Automotive Bulletins and service documents are intended for use by experienced and trained Technicians. If you lack the skills, tools, equipment and a suitable workshop for any procedure described in this document, we suggest you leave such repairs to a Karma retailer and service provider. See your service provider for advice on whether your vehicle may benefit from the information contained within this document. The information contained in the Karma Bulletin is accurate at the date of publication. However, Karma Automotive regularly updates technical information. Please check with your Karma Automotive Retailer and Karma Automotive service provider that the bulletin you intend to use contains the latest available information.

MODEL: Karma Revero**DATE: February 2018****First Release****TITLE: Brake Squeak Remedy**

Aside from the standard service lubricant applied to shims on the backing plate of brake pads (front pads (fig 3a, rear pads fig. 3b).

Apply a small amount (approximately 1-2 mm thick) of Copper Brake Paste only to the leading and trailing edge of the steel backing plate of each brake pad.



fig 3a



fig 3b

Test drive vehicle, verify concern is no longer present.

Karma Automotive Bulletins and service documents are intended for use by experienced and trained Technicians. If you lack the skills, tools, equipment and a suitable workshop for any procedure described in this document, we suggest you leave such repairs to a Karma retailer and service provider. See your service provider for advice on whether your vehicle may benefit from the information contained within this document. The information contained in the Karma Bulletin is accurate at the date of publication. However, Karma Automotive regularly updates technical information. Please check with your Karma Automotive Retailer and Karma Automotive service provider that the bulletin you intend to use contains the latest available information.



Technical Service Bulletin

TB-18-50-01

MODEL: Karma Revero

DATE: February 2018

TITLE: Brake Squeak Remedy

First Release

PARTS (If needed):

PART NUMBER	DESCRIPTION	QUANTITY
C161125100300	Kit - Shim and Grease - Front	1
C161125200300	Kit - Shim and Grease - Rear	1

SHOP SUPPLIES:

DESCRIPTION
Copper Brake Paste (Molykote CU-7439 Recommended)

SPECIAL TOOLS:

DESCRIPTION
N/A

CAUSAL PART:

PART NUMBER	DESCRIPTION
C161125113000	Front Brake Pads

LABOR CODE:

CODE	DESCRIPTION	TIME	DEFECT CODE
50-30-22-08	Brake Lining Prep Bulletin	1.4	50-30-22-12

SUBLET:

CODE (Service)	DESCRIPTION	AMOUNT
N/A		

WARRANTY DISPOSITION: This repair is covered under the New Vehicle Limited Warranty, in effect for five (5) years from the in-service date with no mileage limitation.

Karma Automotive Bulletins and service documents are intended for use by experienced and trained Technicians. If you lack the skills, tools, equipment and a suitable workshop for any procedure described in this document, we suggest you leave such repairs to a Karma retailer and service provider. See your service provider for advice on whether your vehicle may benefit from the information contained within this document. The information contained in the Karma Bulletin is accurate at the date of publication. However, Karma Automotive regularly updates technical information. Please check with your Karma Automotive Retailer and Karma Automotive service provider that the bulletin you intend to use contains the latest available information.