

**MODEL:** Karma Revero

**DATE:** November 2017

**TITLE:** Pilot-Proximity Cable Harness Overlay

**Revised February 2018**

**PRIORITY:** All Revero

**APPLICABILITY:** On complaint for MY17 and MY18 Revero (see attached VIN list)

**MARKET REGION:** North America

**PURPOSE:** Overlaying a harness under the rear package shelf.

Before working on the harness perform a 12V disconnect.

Have the necessary tools required to perform work on a electrical harness:

- wire snips
- needle nose pliers
- highest quality electrical tape
- cable ties (fig. 1a,b)
- standard type automotive connector pick

It is recommended to use: Delphi TPA Hook Pick (13899610), Round Pick (15350707) and Insertion tool (33129228) if available (fig.2).

The Pilot-Proximity cable assembly (C161190100100) is required to perform this repair, order form Karma Automotive (fig.3a,b,c).



fig. 1a



fig. 1b

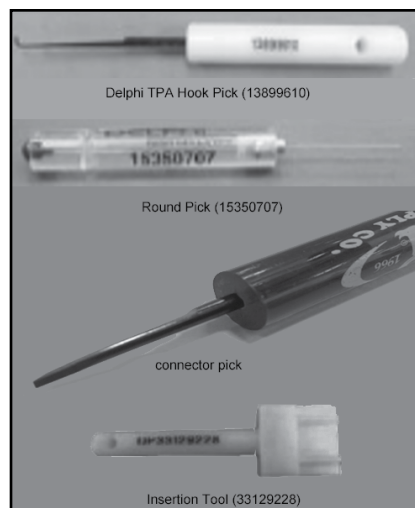

fig. 2

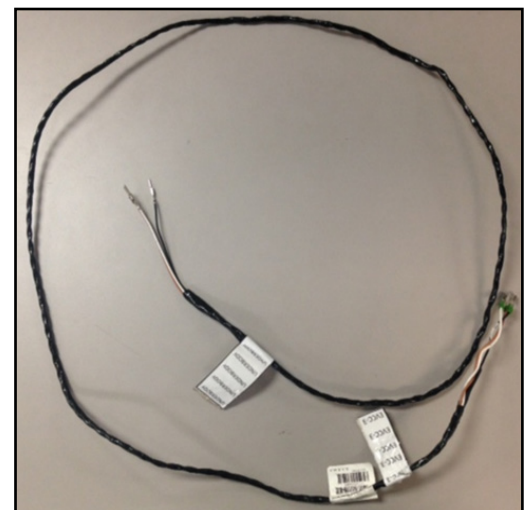

fig. 3a

Karma Automotive Bulletins and service documents are intended for use by experienced and trained Technicians. If you lack the skills, tools, equipment and a suitable workshop for any procedure described in this document, we suggest you leave such repairs to a Karma retailer and service provider. See your service provider for advice on whether your vehicle may benefit from the information contained within this document. The information contained in the Karma Bulletin is accurate at the date of publication. However, Karma Automotive regularly updates technical information. Please check with your Karma Automotive Retailer and Karma Automotive service provider that the bulletin you intend to use contains the latest available information.



# Service Campaign

CC-17-90-12

**MODEL: Karma Revero**

**DATE: November 2017**

**TITLE: Pilot-Proximity Cable Harness Overlay**

**Revised February 2018**

The current vehicles are subject to this bulletin: Before proceeding, verify the work has not been completed as part of BL1030 hardware install.

50GK41SA7HA000014	50GK41SA0JA000023
50GK41SA0HA000016	50GK41SA6JA000026
50GK41SA4HA000018	50GK41SA8JA000027
50GK41SA6HA000019	50GK41SAXJA000028
50GK41SA8HA000023	50GK41SA1JA000029
50GK41SA4HA000021	50GK41SA8JA000030
50GK41SA6HA000022	50GK41SAXJA000031
50GK41SA2HA000020	50GK41SA1JA000032
50GK41SAXHA000024	50GK41SA3JA000033
50GK41SA3HA000012	50GK41SA5JA000034
50GK41SA2JA000007	50GK41SA7JA000035
50GK41SA4JA000011	50GK41SA2JA000010
50GK41SA6JA000012	50GK41SA9JA000036
50GK41SA8JA000013	50GK41SA0JA000037
50GK41SAXJA000014	50GK41SA2JA000038
50GK41SA1JA000015	50GK41SA4JA000039
50GK41SA3JA000016	50GK41SA6JA000009
50GK41SA5JA000017	50GK41SA0JA000040
50GK41SA7JA000021	50GK41SA2JA000041
50GK41SA9JA000019	50GK41SA4JA000042
50GK41SA5JA000020	50GK41SA6JA000043
	50GK41SA8JA000044

Karma Automotive Bulletins and service documents are intended for use by experienced and trained Technicians. If you lack the skills, tools, equipment and a suitable workshop for any procedure described in this document, we suggest you leave such repairs to a Karma retailer and service provider. See your service provider for advice on whether your vehicle may benefit from the information contained within this document. The information contained in the Karma Bulletin is accurate at the date of publication. However, Karma Automotive regularly updates technical information. Please check with your Karma Automotive Retailer and Karma Automotive service provider that the bulletin you intend to use contains the latest available information.

**MODEL:** Karma Revero

**DATE:** November 2017

**TITLE:** Pilot-Proximity Cable Harness Overlay

**Revised February 2018**

The Pilot-Proximity cable assembly (C161190100100) is labeled as shown in (fig 3b, c). the EVCC side connects to the EVCC, the Underbody label refers to the harness inline connector, C312, this will be installed into (brown intrunk connector).

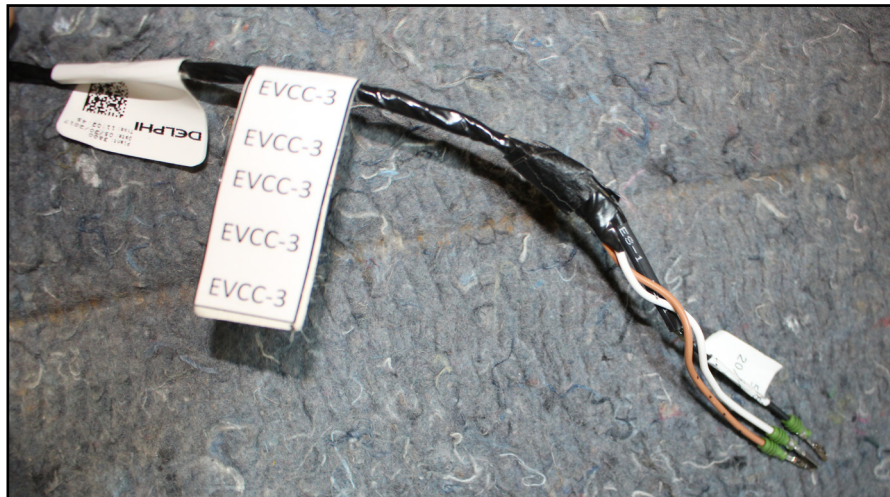

fig. 3b

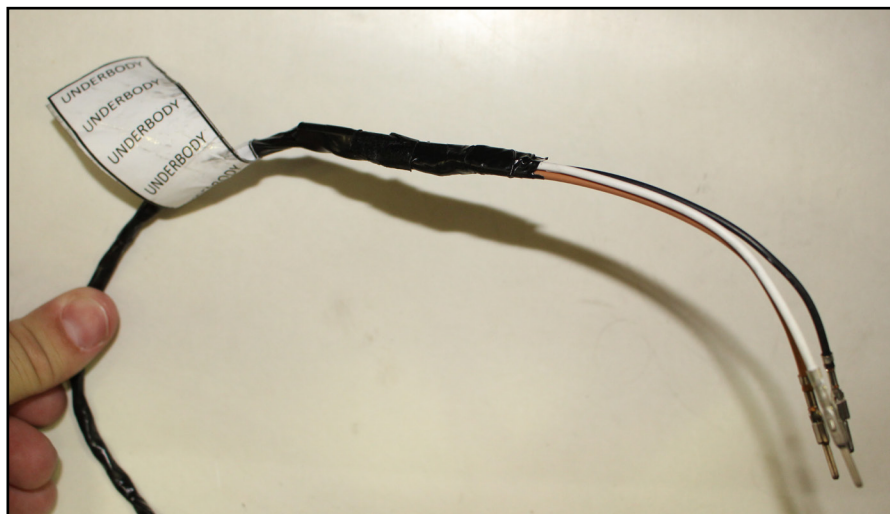

fig. 3c

Karma Automotive Bulletins and service documents are intended for use by experienced and trained Technicians. If you lack the skills, tools, equipment and a suitable workshop for any procedure described in this document, we suggest you leave such repairs to a Karma retailer and service provider. See your service provider for advice on whether your vehicle may benefit from the information contained within this document. The information contained in the Karma Bulletin is accurate at the date of publication. However, Karma Automotive regularly updates technical information. Please check with your Karma Automotive Retailer and Karma Automotive service provider that the bulletin you intend to use contains the latest available information.

**MODEL:** Karma Revero

**DATE:** November 2017

**Revised February 2018**

**TITLE: Pilot-Proximity Cable Harness Overlay**

1. Remove trim and some rear interior. This will include:
    - Rear seats (consult the Service Manual for details if needed)
    - Rear Package tray
    - Rear center console (to access/remove plate covering EVCC)
    - The trunk trim, to access the harness under the rear package tray.
- The overlay harness will run as shown (fig.4a) and through the trunk (fig.4b)

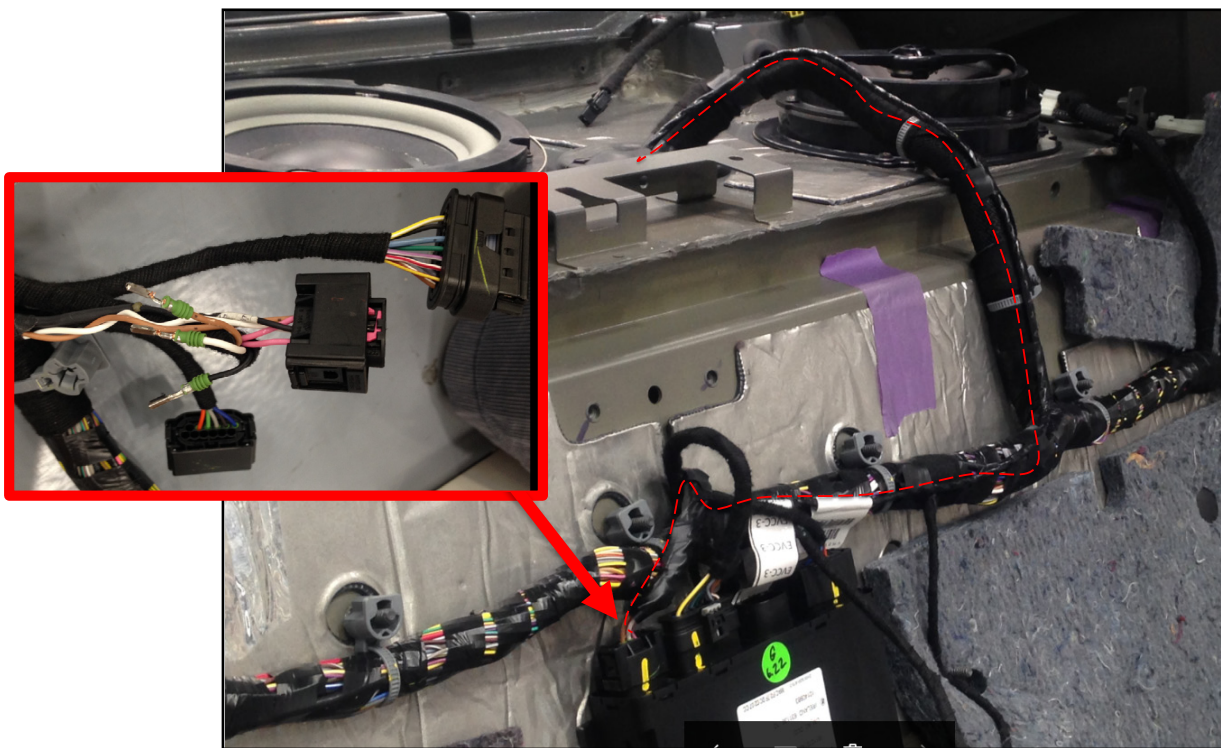

fig. 4a

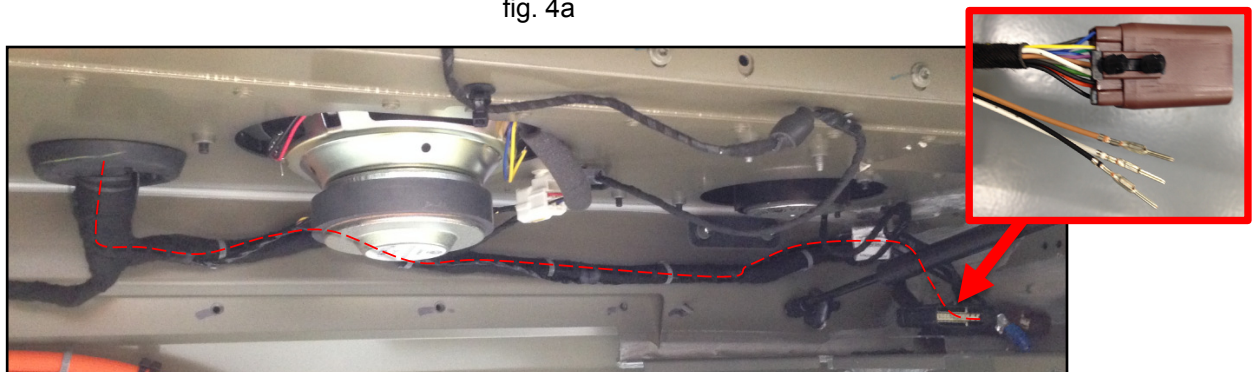

fig. 4b

Karma Automotive Bulletins and service documents are intended for use by experienced and trained Technicians. If you lack the skills, tools, equipment and a suitable workshop for any procedure described in this document, we suggest you leave such repairs to a Karma retailer and service provider. See your service provider for advice on whether your vehicle may benefit from the information contained within this document. The information contained in the Karma Bulletin is accurate at the date of publication. However, Karma Automotive regularly updates technical information. Please check with your Karma Automotive Retailer and Karma Automotive service provider that the bulletin you intend to use contains the latest available information.

**MODEL:** Karma Revero

**DATE:** November 2017

**TITLE:** Pilot-Proximity Cable Harness Overlay

**Revised February 2018**

2. Route the cable overlay as described above, a hole will need to be made in the grommet, towards the center away from the molded arrow (indicated in fig.5b). This is the pass through section from the package tray to the trunk area (fig. 5a).



fig. 5a

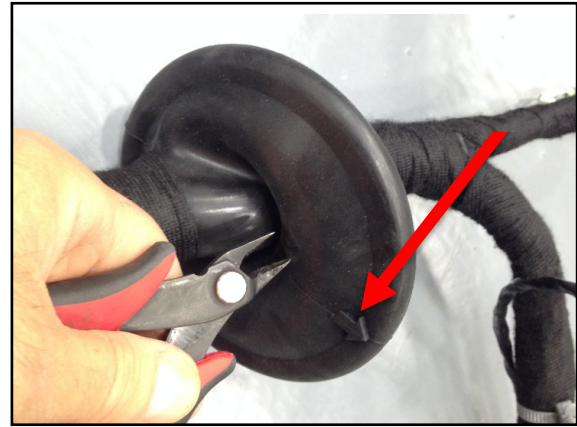

fig. 5b

Spread the hole with pliers (fig. 5c) to allow space to pass the cable assembly through (fig. 5d). This is shown from bench photos for clarity, this procedure can be done in the vehicle.



fig. 5c



fig. 5d

Karma Automotive Bulletins and service documents are intended for use by experienced and trained Technicians. If you lack the skills, tools, equipment and a suitable workshop for any procedure described in this document, we suggest you leave such repairs to a Karma retailer and service provider. See your service provider for advice on whether your vehicle may benefit from the information contained within this document. The information contained in the Karma Bulletin is accurate at the date of publication. However, Karma Automotive regularly updates technical information. Please check with your Karma Automotive Retailer and Karma Automotive service provider that the bulletin you intend to use contains the latest available information.

**MODEL:** Karma Revero

**DATE:** November 2017

**TITLE:** Pilot-Proximity Cable Harness Overlay

**Revised February 2018**

3. The Inline Connector C312 is shown here behind the gray one in (fig. 6a). The over lay harness will begin modification here, swapping pins from position 11, 12, 13 as indicated (fig.6b)

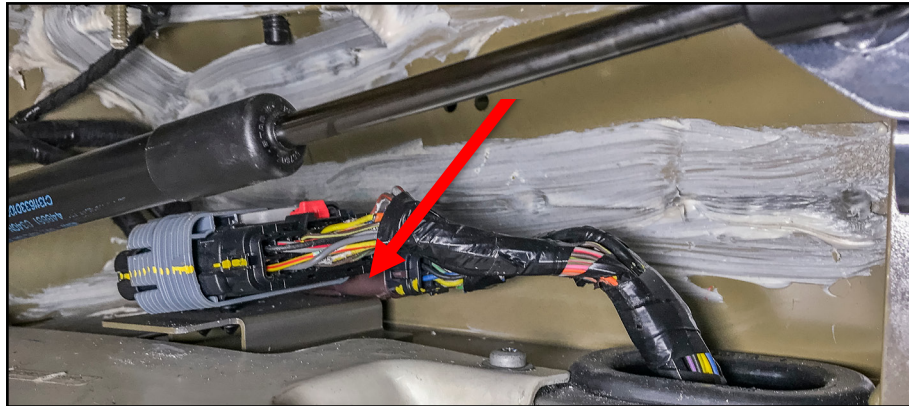

fig. 6a

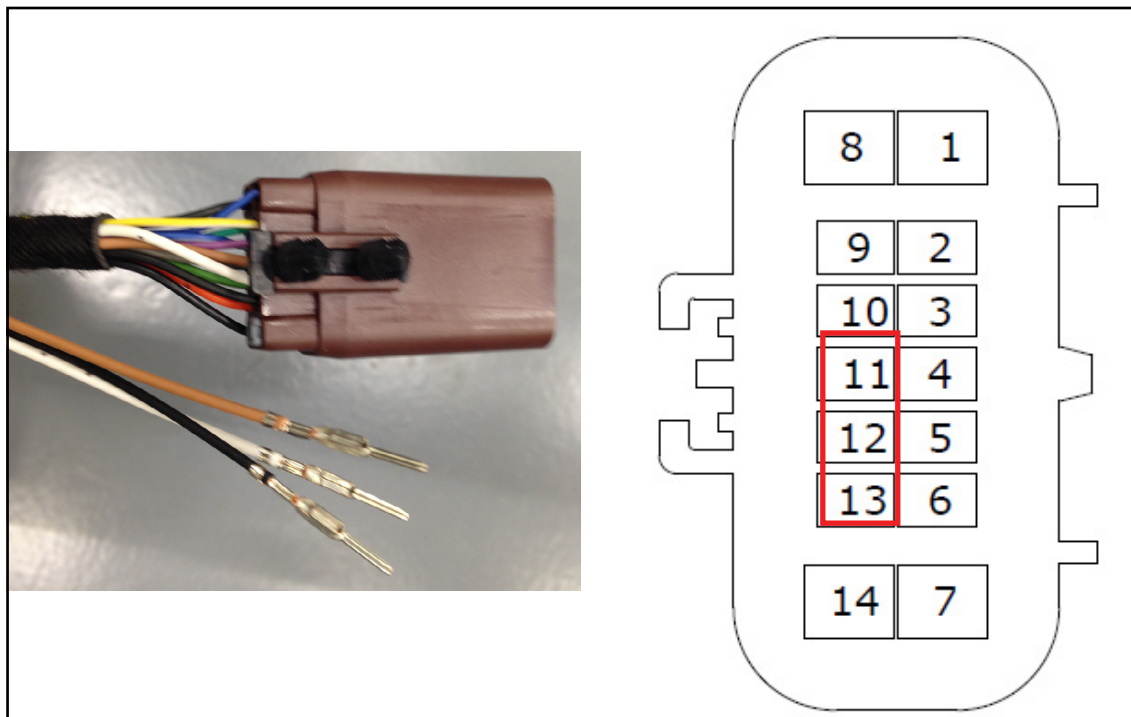

fig. 6b

Karma Automotive Bulletins and service documents are intended for use by experienced and trained Technicians. If you lack the skills, tools, equipment and a suitable workshop for any procedure described in this document, we suggest you leave such repairs to a Karma retailer and service provider. See your service provider for advice on whether your vehicle may benefit from the information contained within this document. The information contained in the Karma Bulletin is accurate at the date of publication. However, Karma Automotive regularly updates technical information. Please check with your Karma Automotive Retailer and Karma Automotive service provider that the bulletin you intend to use contains the latest available information.

MODEL: Karma Revero

DATE: November 2017

TITLE: Pilot-Proximity Cable Harness Overlay

Revised February 2018

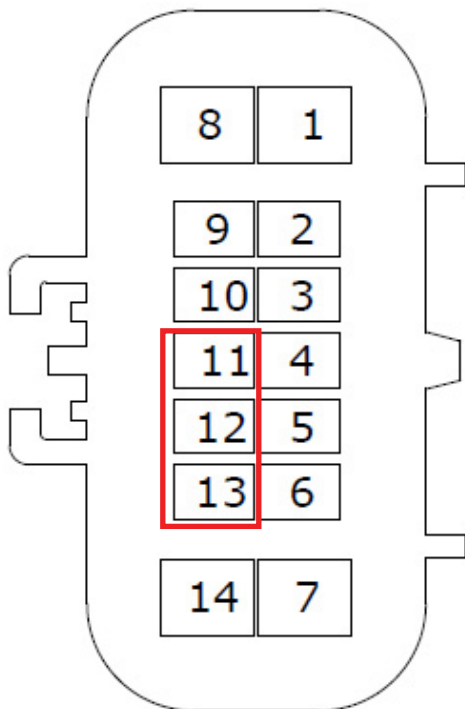

BRN

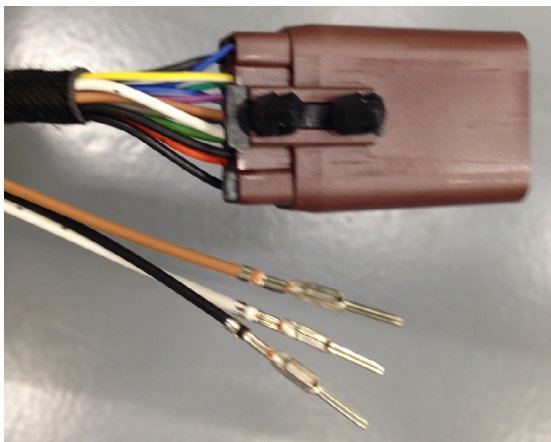

ITEM NO: C315 @ J87

DPN: 13977354

INLINE-TO CHSIS-3

13768145 - MOUN ATTCH CLIP FIR TREE ...

CAV	WIRE	
1	GDA405F	
2	WUP010B	
3	PA001G	
4	LVDC003B	
5	LVDC004B	
6	LVDC005B	
7	GDA410A	
8	SA217B	
9	PA007C	
10	PA008C	
11	LVDC006B	Brown
12	LVDC007B	White
13	LVDC010E	Black
14	13765188	
SYMBOL	ALL	

fig. 7

This is the pin out for the brown inline connector, C315 (fig. 7). Tape back unused loose terminals (pins).

Karma Automotive Bulletins and service documents are intended for use by experienced and trained Technicians. If you lack the skills, tools, equipment and a suitable workshop for any procedure described in this document, we suggest you leave such repairs to a Karma retailer and service provider. See your service provider for advice on whether your vehicle may benefit from the information contained within this document. The information contained in the Karma Bulletin is accurate at the date of publication. However, Karma Automotive regularly updates technical information. Please check with your Karma Automotive Retailer and Karma Automotive service provider that the bulletin you intend to use contains the latest available information.

MODEL: Karma Revero

DATE: November 2017

TITLE: Pilot-Proximity Cable Harness Overlay

Revised February 2018

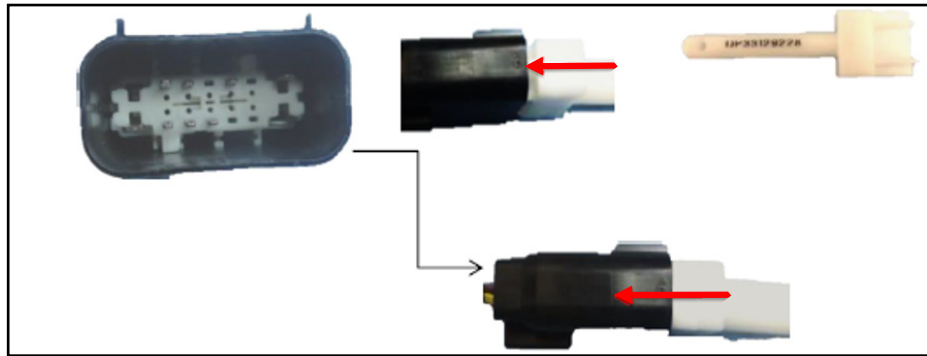

fig. 8a

4. Use the TPA Insertion tool to set it in the locking position. The device connector for EVCC, D3818-3, is to be using the TPA Pick tool, hook and pull form one end to release the TPA (fig. 8a,b,c,d)

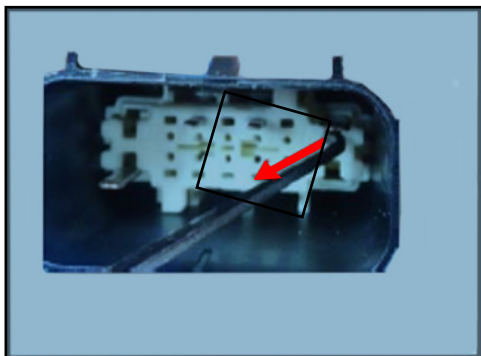

fig. 8b



fig. 8c



fig. 8d

5. Using the Round Pick, Insert to the corresponding position to unlock the terminal (11,12,13) as shown (fig 8e).

Pull the corresponding cable from the back of the connector to remove it from the connector



fig. 8e

Karma Automotive Bulletins and service documents are intended for use by experienced and trained Technicians. If you lack the skills, tools, equipment and a suitable workshop for any procedure described in this document, we suggest you leave such repairs to a Karma retailer and service provider. See your service provider for advice on whether your vehicle may benefit from the information contained within this document. The information contained in the Karma Bulletin is accurate at the date of publication. However, Karma Automotive regularly updates technical information. Please check with your Karma Automotive Retailer and Karma Automotive service provider that the bulletin you intend to use contains the latest available information.

**MODEL:** Karma Revero

**DATE:** November 2017

**Revised February 2018**

**TITLE: Pilot-Proximity Cable Harness Overlay**

6. Use the TPA Insertion tool to set it in the locking position (Fig. 9a,b) back out the black cover is removed by pushing on the tabs (fig.c) and moving it as shown in (fig. 9d).

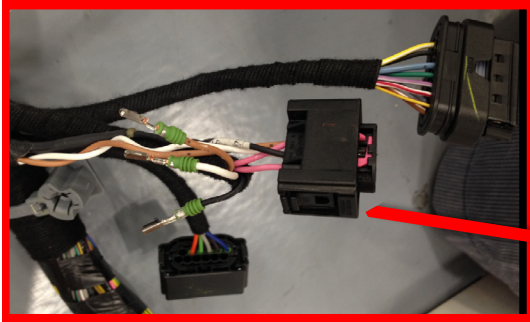

fig. 9a

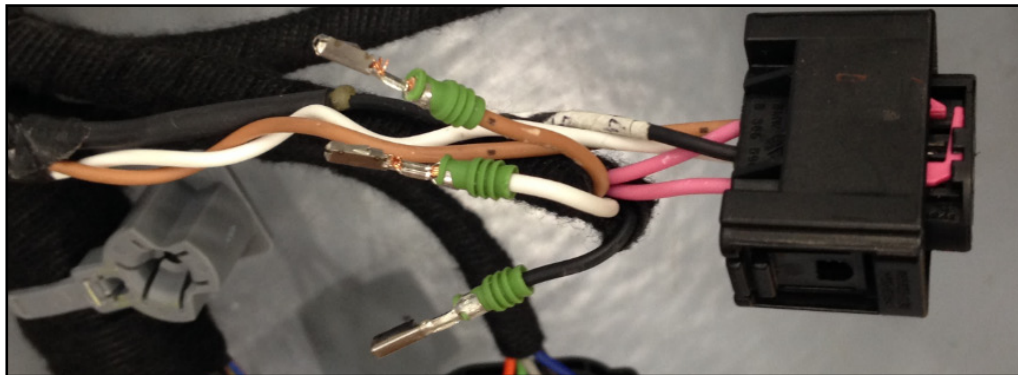
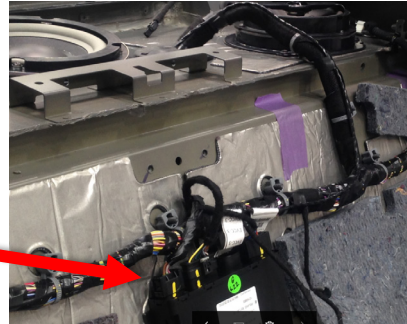

fig. 9b

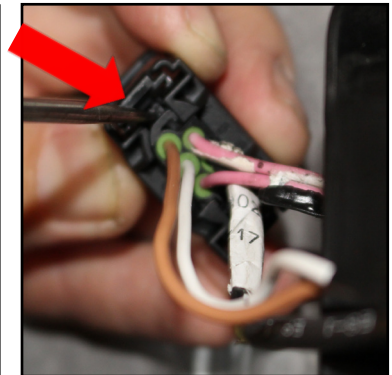

fig. 9c

7. Slide the pink locking tab to remove wires and insert new harness overlay (fig. 9d,e,f)

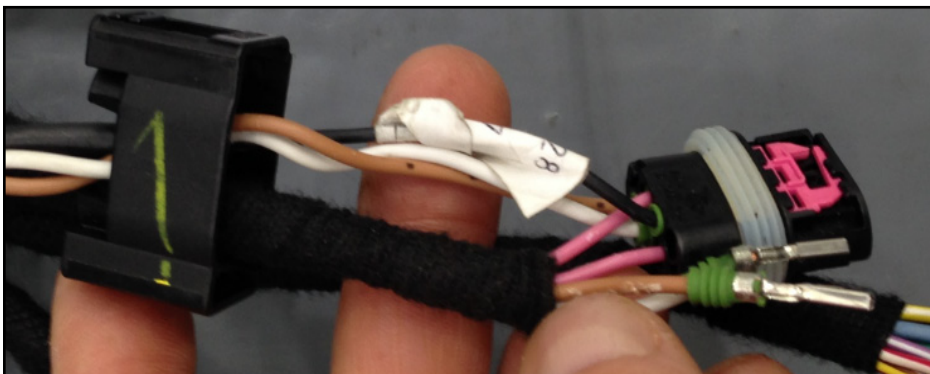

fig. 9d

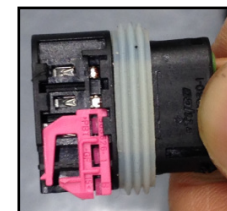

fig. 9e

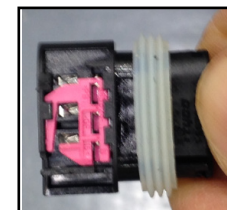

fig. 9f

Karma Automotive Bulletins and service documents are intended for use by experienced and trained Technicians. If you lack the skills, tools, equipment and a suitable workshop for any procedure described in this document, we suggest you leave such repairs to a Karma retailer and service provider. See your service provider for advice on whether your vehicle may benefit from the information contained within this document. The information contained in the Karma Bulletin is accurate at the date of publication. However, Karma Automotive regularly updates technical information. Please check with your Karma Automotive Retailer and Karma Automotive service provider that the bulletin you intend to use contains the latest available information.

**MODEL:** Karma Revero

**DATE:** November 2017

**Revised February 2018**

**TITLE:** Pilot-Proximity Cable Harness Overlay

8. The wires indicated for the connector D3818-3 will need to be moved out and replaced with the overlay harness (fig 10a) Tape back unused loose terminals.

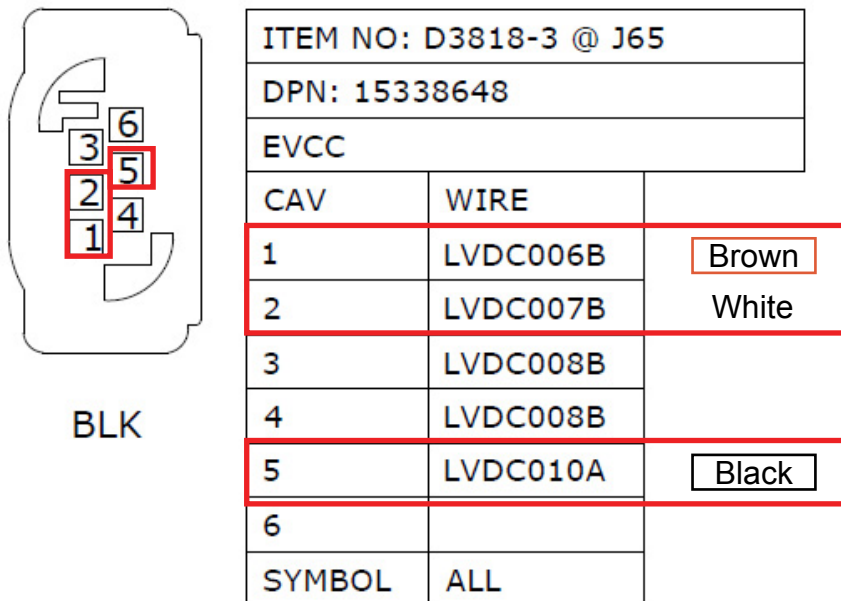

fig. 10a

- Use cable ties on the overlay harness to secure it to the Body Harness every 200mm. Tape back unused loosed terminals.
- Reassemble the interior trim and trunk trim in the reverse of removal. Check for any diagnostic trouble codes and function of rear seat cushion heaters as per bulletin SC-17-86-20.

### ⚠ **NOTICE!** ⚠

After all BL1030 hardware bulletins are completed as applicable, contact TSS for instructions on how to proceed with the firmware updates. See Bulletin CC-17-00-29 Baseline 1030 Firmware Release. Verify upper hose clamp torque be checked on ALL vehicles as described in bulletin: TB-18-20-01 Radiator Hose Clamp Inspection. Please check for new bulletins posted on the Karma website verify all new bulletins are read as performed as required.

Karma Automotive Bulletins and service documents are intended for use by experienced and trained Technicians. If you lack the skills, tools, equipment and a suitable workshop for any procedure described in this document, we suggest you leave such repairs to a Karma retailer and service provider. See your service provider for advice on whether your vehicle may benefit from the information contained within this document. The information contained in the Karma Bulletin is accurate at the date of publication. However, Karma Automotive regularly updates technical information. Please check with your Karma Automotive Retailer and Karma Automotive service provider that the bulletin you intend to use contains the latest available information.



# Service Campaign

## CC-17-90-12

**MODEL:** Karma Revero

**DATE:** November 2017

Revised February 2018

**TITLE:** Pilot-Proximity Cable Harness Overlay

**PARTS REQUIRED:**

PART NUMBER	DESCRIPTION
C161190100100	Pilot-Proximity Overlay Cable Assembly

**SHOP SUPPLIES:**

DESCRIPTION
N/A

**SPECIAL TOOLS:**

PART NUMBER	DESCRIPTION
N/A	

**CAUSAL PART:**

PART NUMBER	DESCRIPTION
C131190500105	Harness - Body

**LABOR CODES:**

CODE	DESCRIPTION	TIME	DEFECT CODE
90-10-20-05	Pilot-Proximity Overlay Harness Install	1.5	90-10-20-17
90-10-20-07	OVERLAP Pilot-Proximity Overlay*	0.5	90-10-20-17

**\*Please refer to Service Communication SC-17-01-36 – BL1030 Release Supplement for special claim submission instructions. If performing this bulletin at the same time as CC-17-94-24, Amplifier Replacement only use the second labor code due to overlap in labor.**

**SUBLET:**

CODE	DESCRIPTION	AMOUNT
N/A		

**WARRANTY DISPOSITION:** This repair is covered under the New Vehicle Limited Warranty, in effect for five (5) years from the in-service date with no mileage limitation.

Karma Automotive Bulletins and service documents are intended for use by experienced and trained Technicians. If you lack the skills, tools, equipment and a suitable workshop for any procedure described in this document, we suggest you leave such repairs to a Karma retailer and service provider. See your service provider for advice on whether your vehicle may benefit from the information contained within this document. The information contained in the Karma Bulletin is accurate at the date of publication. However, Karma Automotive regularly updates technical information. Please check with your Karma Automotive Retailer and Karma Automotive service provider that the bulletin you intend to use contains the latest available information.