



# SERVICE BULLETIN

Classification: AT15-003e	Reference: NTB15-037e	Date: February 2, 2018
------------------------------	--------------------------	---------------------------

## VERSA SEDAN, VERSA NOTE, AND SENTRA; CVT VALVE BODY REPLACEMENT WITH CONFIRMED DTC

This bulletin has been amended. Additional model years were added on pages 1, 3, 7, 15, and 39. Other minor changes were made on page 19, 20, 34, and 38. Please discard all previous versions of this bulletin.

**APPLIED VEHICLES:** 2012 – 2017 Versa Sedan (N17)  
2014 – 2017 Versa NOTE (E12)  
2013 – 2017 Sentra (B17)

**APPLIED TRANSMISSION:** CVT (RE0F11A)

**NOTE:** Does not apply to 2017 Sentra equipped with MR16DDT turbo engine.

### IF YOU CONFIRM

- If one or more of the DTCs listed in the DTC Chart on page 2 are present in the Transmission Control Module (TCM).

And

- No other DTCs are present other than what are listed in the DTC Chart.

### ACTION

1. Go to Repair Overview on page 3 to determine which repairs to perform to the applied vehicle being worked on.

**IMPORTANT:** The purpose of “ACTION” (above) is to give you a quick idea of the work you will be performing. You **MUST** closely follow the entire Service Procedure as it contains information that is essential to successfully completing the repair.

Nissan Bulletins are intended for use by qualified technicians, not 'do-it-yourselfers'. Qualified technicians are properly trained individuals who have the equipment, tools, safety instruction, and know-how to do a job properly and safely. NOTE: If you believe that a described condition may apply to a particular vehicle, DO NOT assume that it does. See your Nissan dealer to determine if this applies to your vehicle.

**DTC Chart**

<b>DTC CODE</b>	<b>DTC/CIRCUIT DIAGNOSIS</b>
P0711	TRANSMISSION FLUID TEMPERATURE SENSOR A
P0712	TRANSMISSION FLUID TEMPERATURE SENSOR A
P0713	TRANSMISSION FLUID TEMPERATURE SENSOR A
P0740	TORQUE CONVERTER
P0743	TORQUE CONVERTER
P0846	TRANSMISSION FLUID PRESSURE SEN/SW B
P0847	TRANSMISSION FLUID PRESSURE SEN/SW B
P0848	TRANSMISSION FLUID PRESSURE SEN/SW B
P0962	PRESSURE CONTROL SOLENOID A
P0963	PRESSURE CONTROL SOLENOID A
P0998	SHIFT SOLENOID F
P0999	SHIFT SOLENOID F
P0966	PRESSURE CONTROL SOLENOID B
P0967	PRESSURE CONTROL SOLENOID B
P099B	SHIFT SOLENOID G
P099C	SHIFT SOLENOID G

## Repair Overview

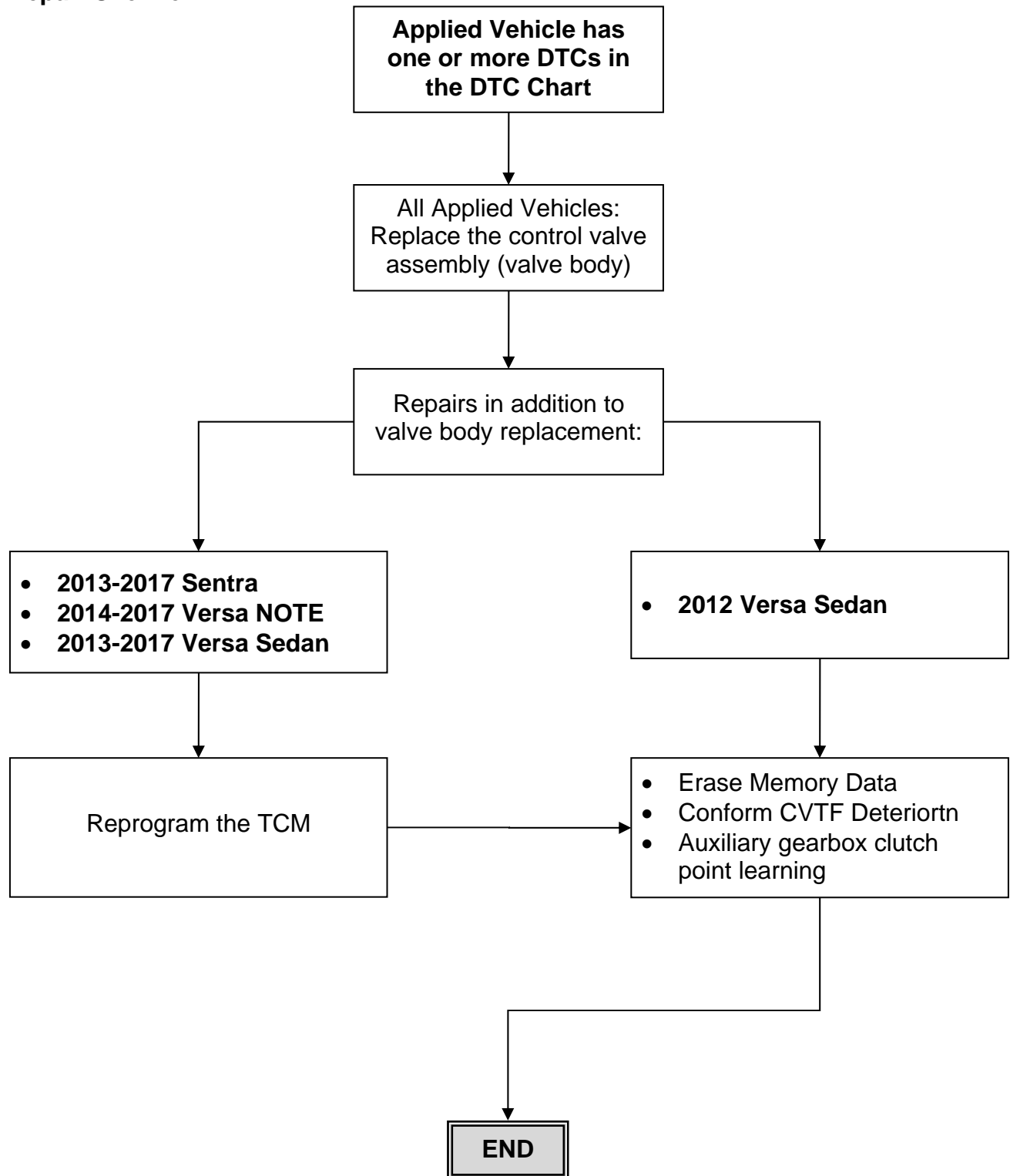

# SERVICE PROCEDURE

## OIL PAN, CONTROL VALVE (Valve Body)

Exploded View

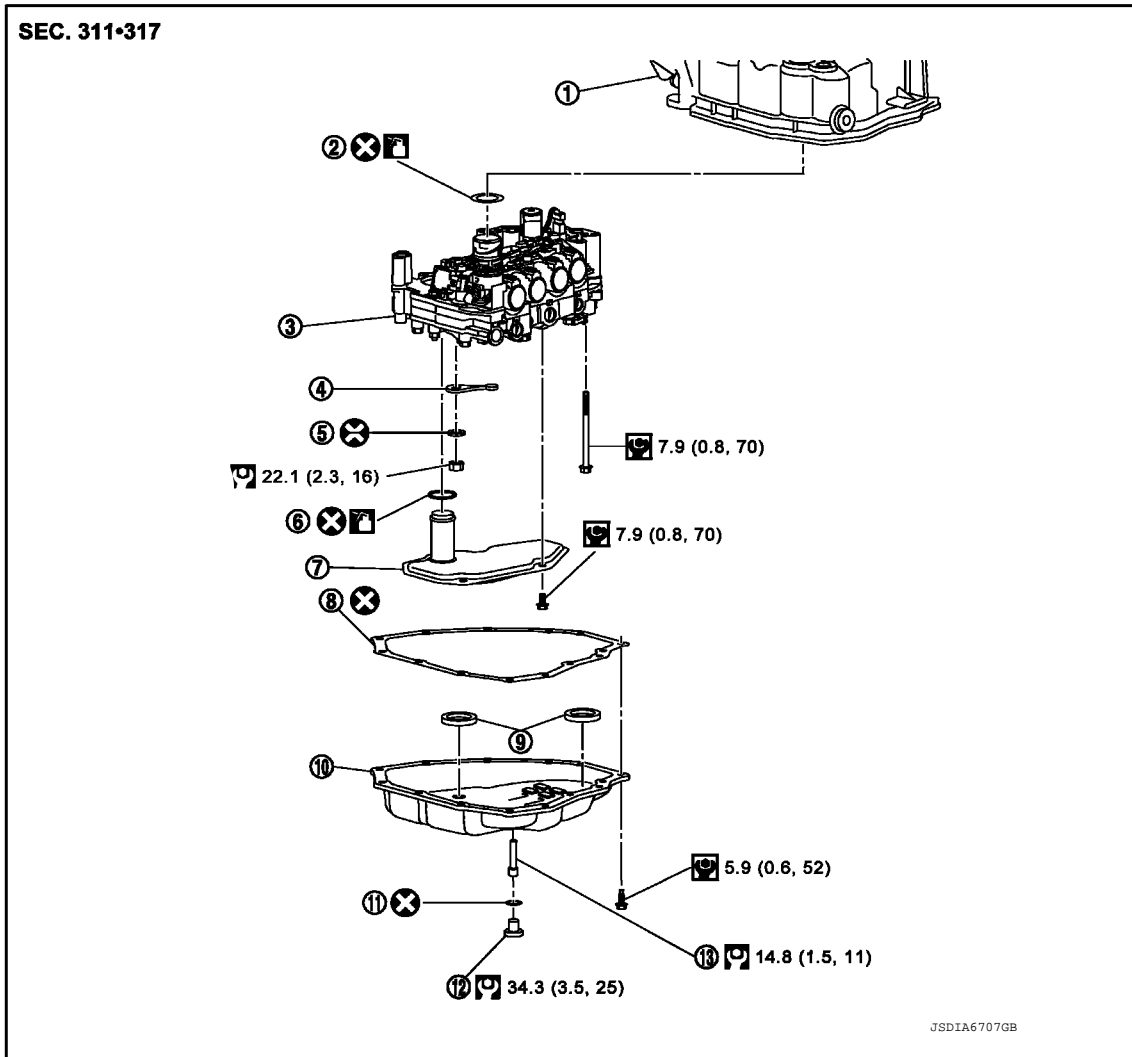

- |                       |                       |                  |
|-----------------------|-----------------------|------------------|
| 1. Transaxle assembly | 2. O-ring             | 3. Control valve |
| 4. Manual plate       | 5. Washer             | 6. O-ring        |
| 7. Strainer           | 8. Oil pan gasket     | 9. Magnet        |
| 10. Oil pan           | 11. Drain plug gasket | 12. Drain plug   |
| 13. Overflow tube     |                       |                  |

: Apply petroleum jelly

: Always replace after every disassembly.

: Apply CVT fluid

: N·m (kg-m, ft-lb)

: N·m (kg-m, in-lb.)

### Valve Body: Removal and Installation

#### REMOVAL

1. Disconnect battery negative terminal.
2. Remove engine under cover.

3. Disconnect the CVT unit harness connector.
4. Remove the drain plug and overflow tube, and then drain the CVT fluid.

**CAUTION:**

**Use caution when looking into the drain hole as there is the risk of fluid entering the eye.**

5. Remove the drain plug gasket from the drain plug.
6. Remove the oil pan mounting bolts (←), and then remove the oil pan and oil pan gasket.

← : Vehicle front

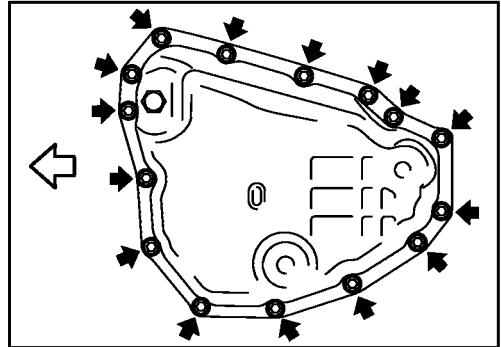

7. Remove the magnets from the oil pan.

- Clean magnets.
- Clean CVT oil pan.
- Reinstall magnets to the oil pan.

8. Remove the strainer bolts (A), and then remove the strainer (1) from the control valve.

- Discard the strainer. A new one will be used during assembly.

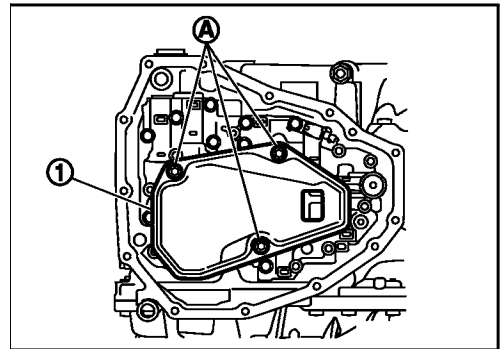

9. Remove the nut (A) and washer (2), and then remove manual plate (1).

**CAUTION:**

**To remove nut, fix manual plate with flat-blade screwdriver (B).**

10. Press the CVT unit harness connector into the transaxle case.

**CAUTION:**

**Never damage the CVT unit harness connector.**

**NOTE:**

Clean around the CVT unit harness connector to prevent foreign materials from entering into the transaxle case.

11. Remove the control valve bolts (A), and then remove the control valve from the transaxle case.

**CAUTION:**

- **Never drop the control valve and manual valve.**

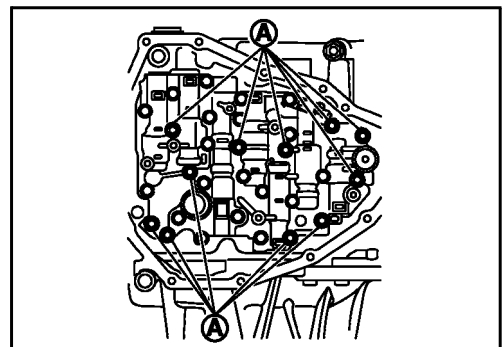
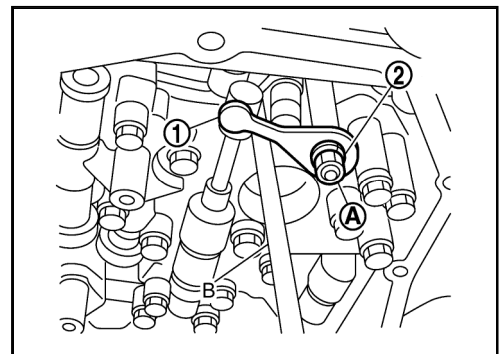

## INSTALLATION

1. Install the control valve, and then tighten control valve bolts ④ to the specified torque.

**CAUTION:**

- Never pinch the harness between the control valve and the transaxle case.
- Never drop the control valve and manual valve.

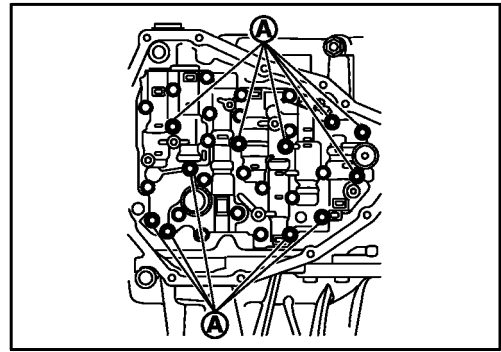

2. Install the manual plate ① and washer ②, and then tighten nut ③ to the specified torque.

**CAUTION:**

To tighten nut, fix manual plate with flat-blade screwdriver.

- Reassembly Torque: 22.1 N•m (2.3 kg-m, 16 ft-lb)

3. Install the new strainer ①, and then tighten the strainer bolts ④ to the specified torque.

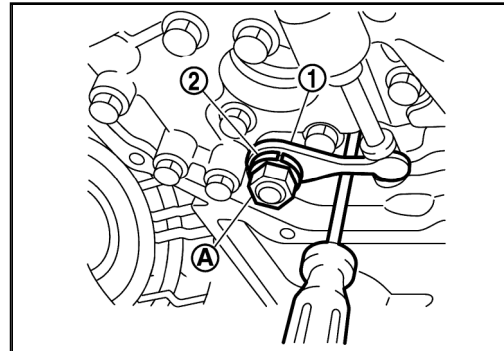

4. Install oil pan (with oil pan gasket) to transaxle case and temporarily tighten oil pan bolts (←).

**CAUTION:**

Never reuse oil pan gasket.

← : Vehicle front

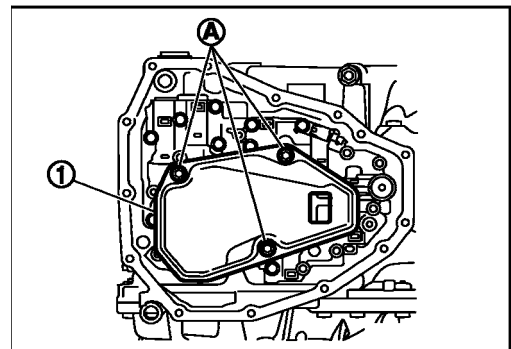

5. Tighten the oil pan bolts to specification in the order shown.

← : Vehicle front

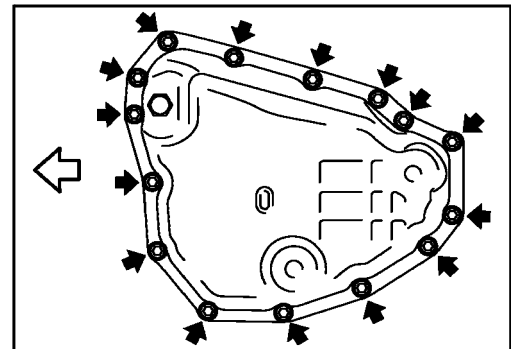

6. Tighten the overflow tube to the specified torque.

**CAUTION:**

If it is not tightened to the specified torque, the tube may be damaged.

7. Connect the CVT unit harness connector.
8. Connect battery negative terminal.
9. Fill with CVT fluid from overflow tube to the specified level. Refer to ESM for further information.
10. Install the drain plug and drain plug gasket to oil pan.

**CAUTION:**

Never reuse drain plug gasket.

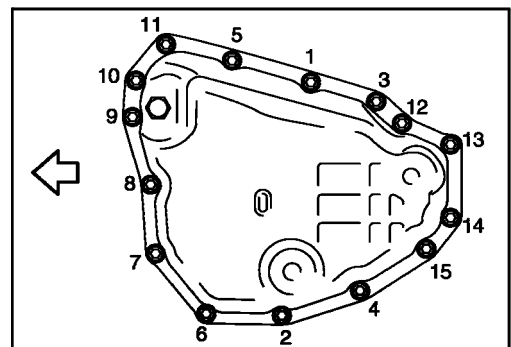

11. Reinstall engine under cover.

## TCM Reprogramming

**IMPORTANT:** Before starting the TCM reprogram procedure, make sure:

- **ASIST on the CONSULT PC has been synchronized (updated) to the current date.**
- **All CONSULT-III plus (C-III plus) software updates (if any) have been installed.**

**NOTE:**

- TCM reprogramming applies to 2014-2017 Versa NOTE, 2013-2017 Sentra, and 2013-2017 Versa Sedan only.
- 2012 Versa Sedan does NOT require reprogramming.
- For more information, see Repair Overview on page 3.

1. Connect the plus Vehicle Interface (plus VI) to the vehicle.

**CAUTION:** Make sure the plus VI is securely connected. If the plus VI connection is loose during reprogramming, the process will be interrupted and the TCM may be damaged.

2. Connect the AC Adapter to the CONSULT PC.

**CAUTION:** Be sure to connect the AC Adapter. If the CONSULT PC battery voltage drops during reprogramming, the process will be interrupted and the TCM may be damaged.

3. Connect the GR8, set to "Power Supply" mode, to the vehicle battery.

**CAUTION:** Be sure the GR8 is connected securely to the battery. Make sure the battery voltage stays between 12.0V and 15.5V during reprogramming. If the battery voltage goes out of this range during reprogramming, the TCM may be damaged.

4. Turn OFF all external Bluetooth® devices (e.g., cell phones, printers, etc.) within range of the CONSULT PC and the VI.

**CAUTION:** Make sure to turn OFF all external Bluetooth® devices. If Bluetooth® signal waves are within range of the CONSULT PC and the VI during reprogramming, reprogramming may be interrupted and the TCM may be damaged.

5. Turn the ignition ON with the engine OFF.

- **The engine must not start or run during the reprogramming procedure.**

6. Turn OFF all vehicle electrical loads such as exterior lights, interior lights, HVAC, blower, rear defogger, audio, NAVI, seat heater, steering wheel heater, etc.

**IMPORTANT:** Make sure to turn OFF all vehicle electrical loads. Make sure the battery voltage stays between 12.0V and 15.5V during reprogramming. If the battery voltage goes out of this range during reprogramming, the TCM may be damaged.

7. Turn ON the CONSULT PC.

8. Select/open C-III plus.

9. Wait for the plus VI to be recognized.

- Serial number will display when the plus VI is recognized.

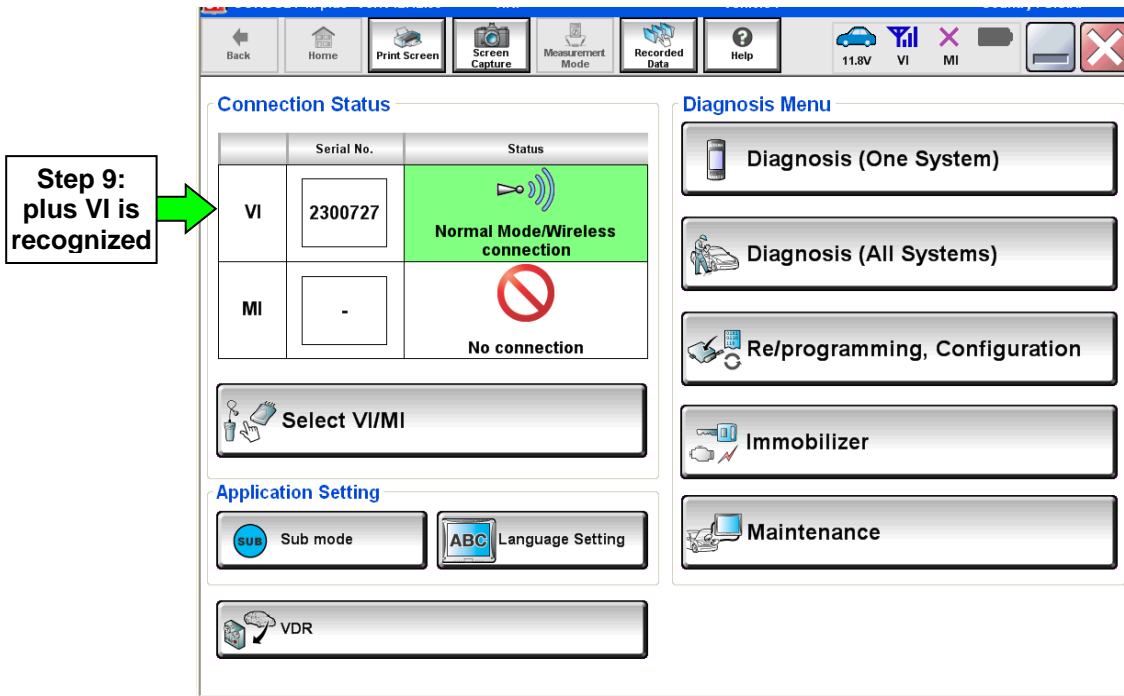

Figure 1

10. Select **Re/programming, Configuration**.

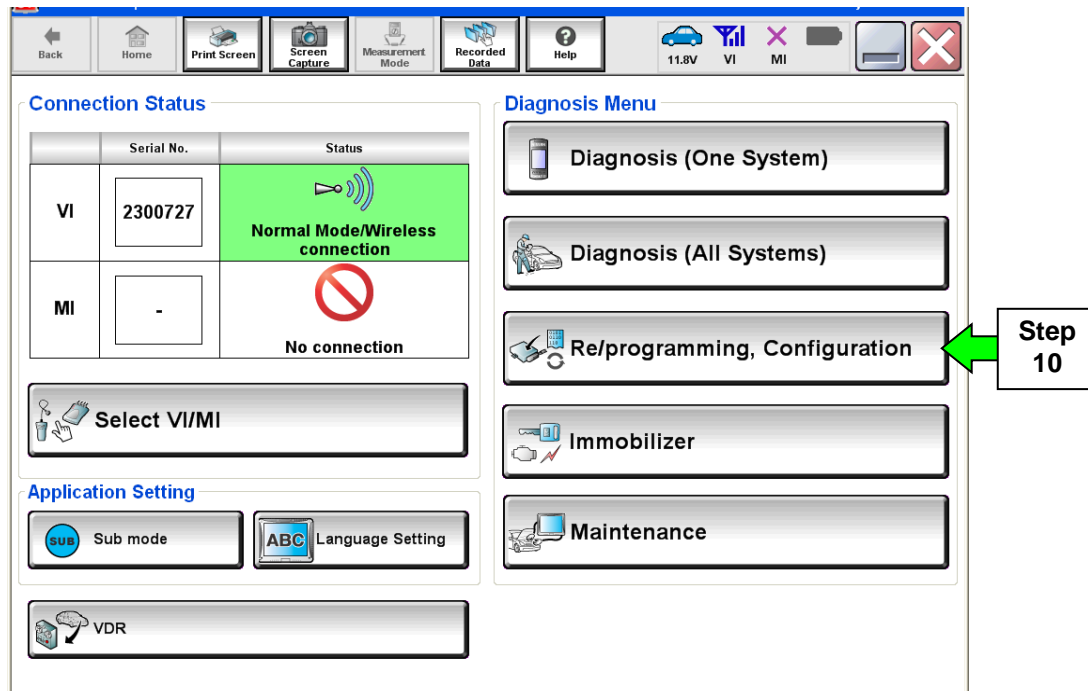

Figure 2



11. Use arrows (if needed) to view and read all precautions.
12. Check the box confirming the precautions have been read.
13. Select **Next**.

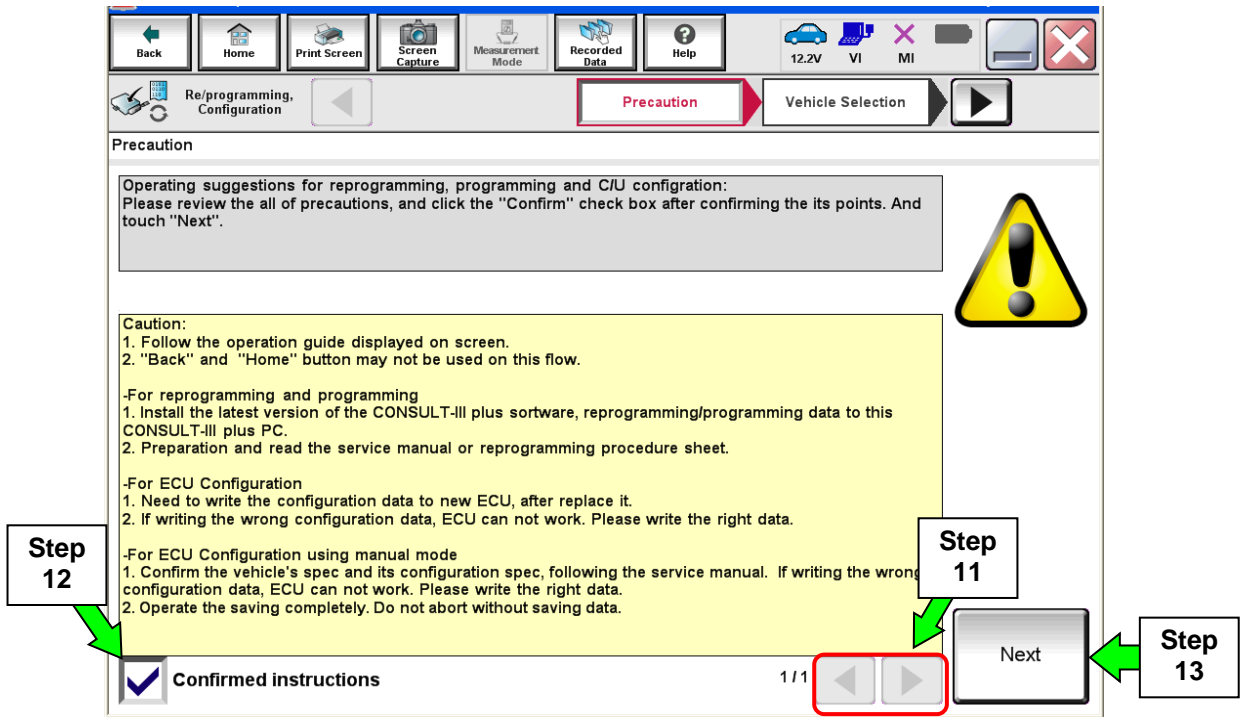

Figure 3

14. If the screen in Figure 4 displays, select **Automatic Selection(VIN)**.

- If the screen in Figure 4 does not display, skip to step 15.

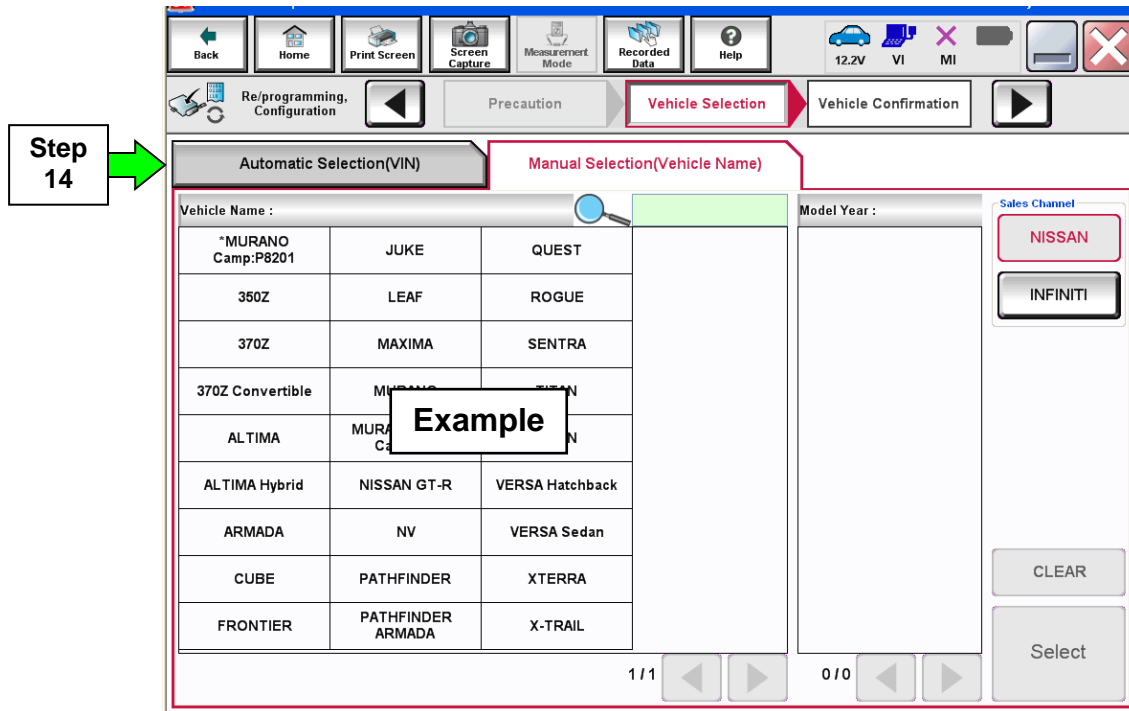

Figure 4

15. Make sure **VIN or Chassis #** matches the vehicle's VIN.

16. If the correct VIN is displayed, select **Confirm**.

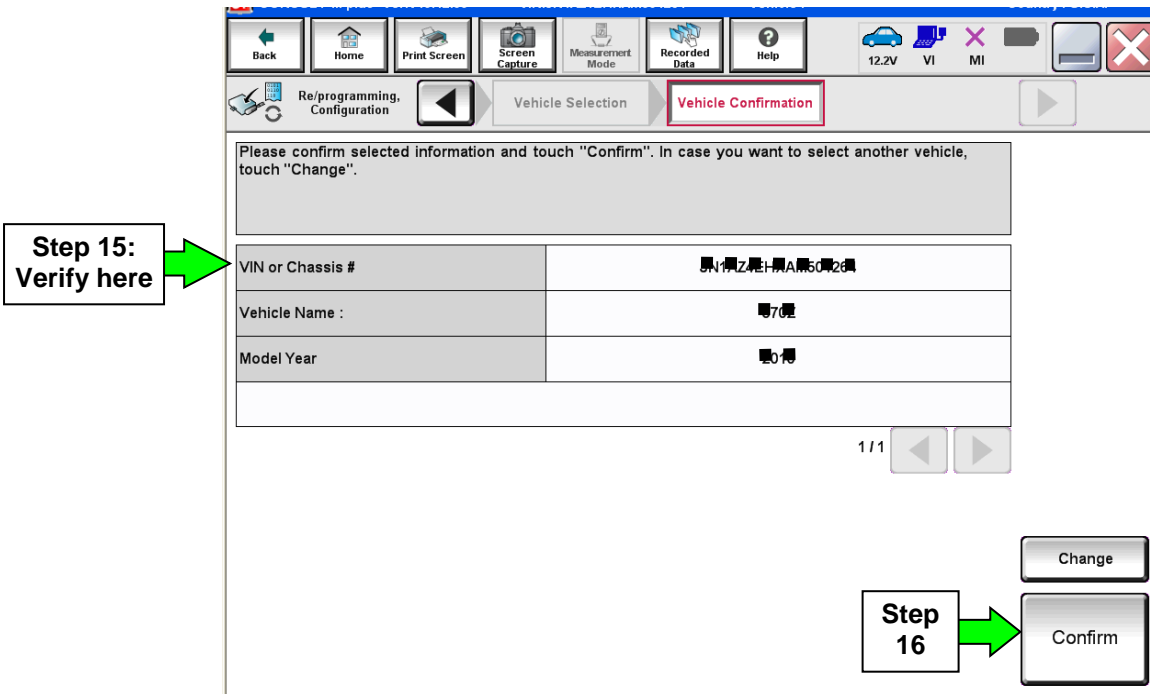

Figure 5

17. Select **Confirm**.

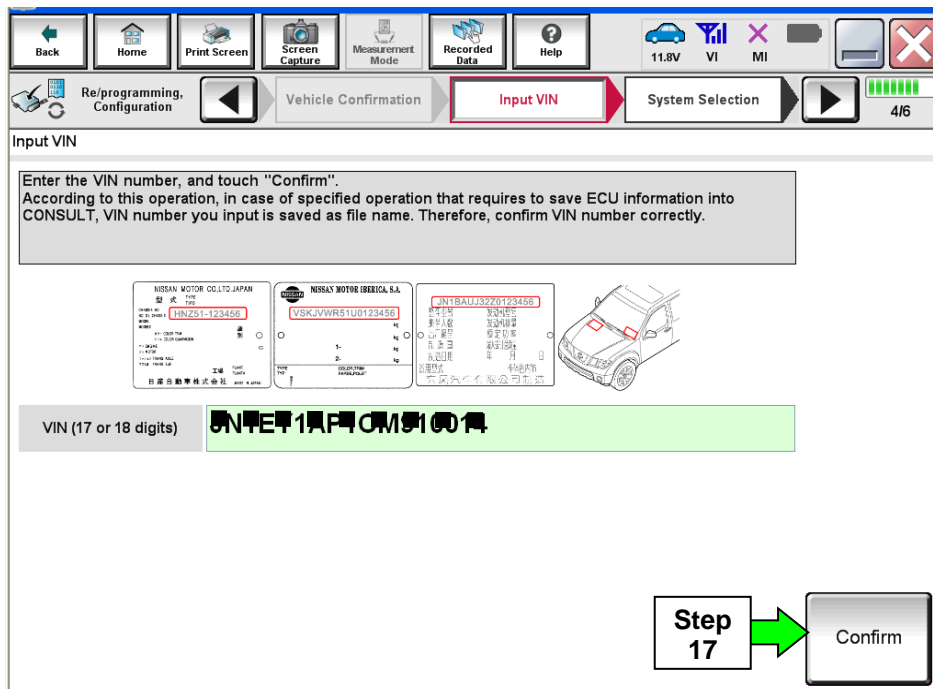

Figure 6

## 18. Select TRANSMISSION.

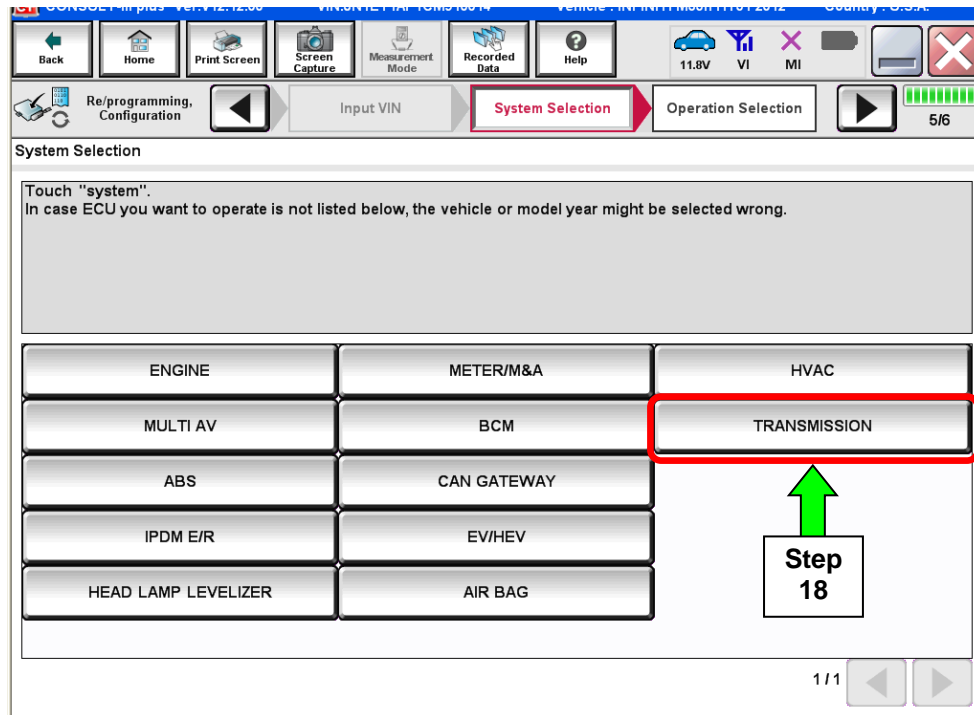

Figure 7

## 19. Select Reprogramming.

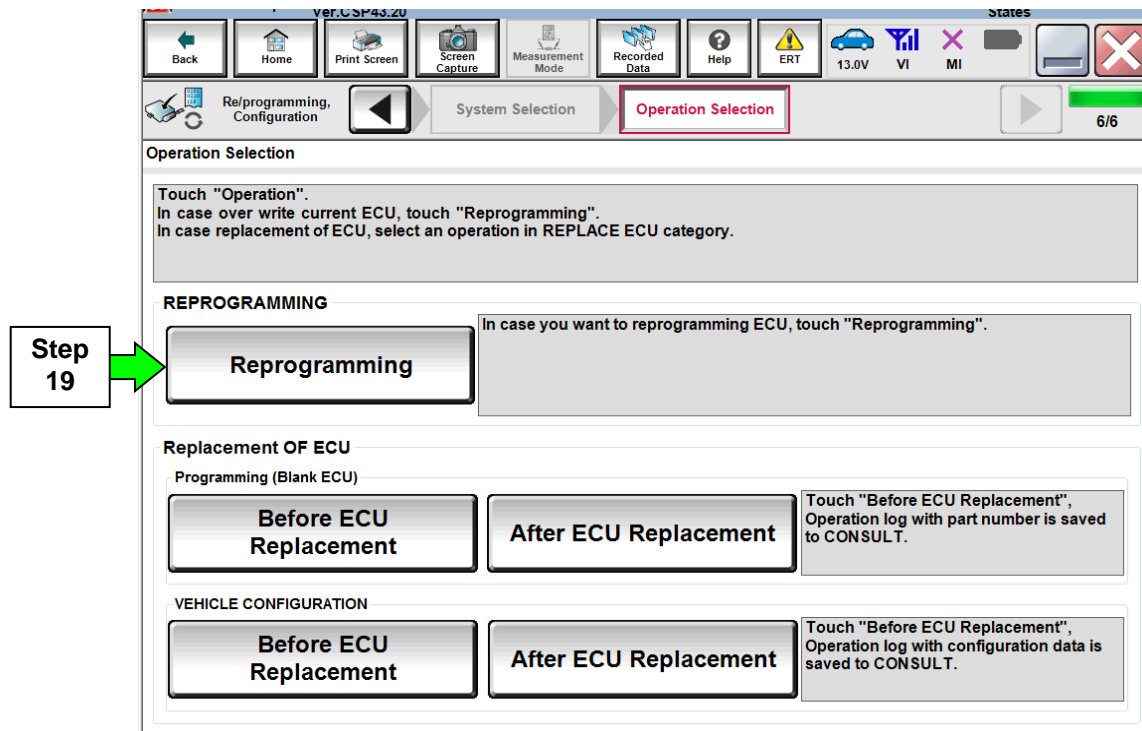

Figure 8

20. Follow the on-screen instructions; maintain the following conditions:

- a. Ignition ON, with the engine OFF.
- b. Press the Brake.
- c. Press accelerator between  $\frac{1}{4}$  and  $\frac{1}{2}$ .
- d. Put shift selector in R.

21. Select **Start**.

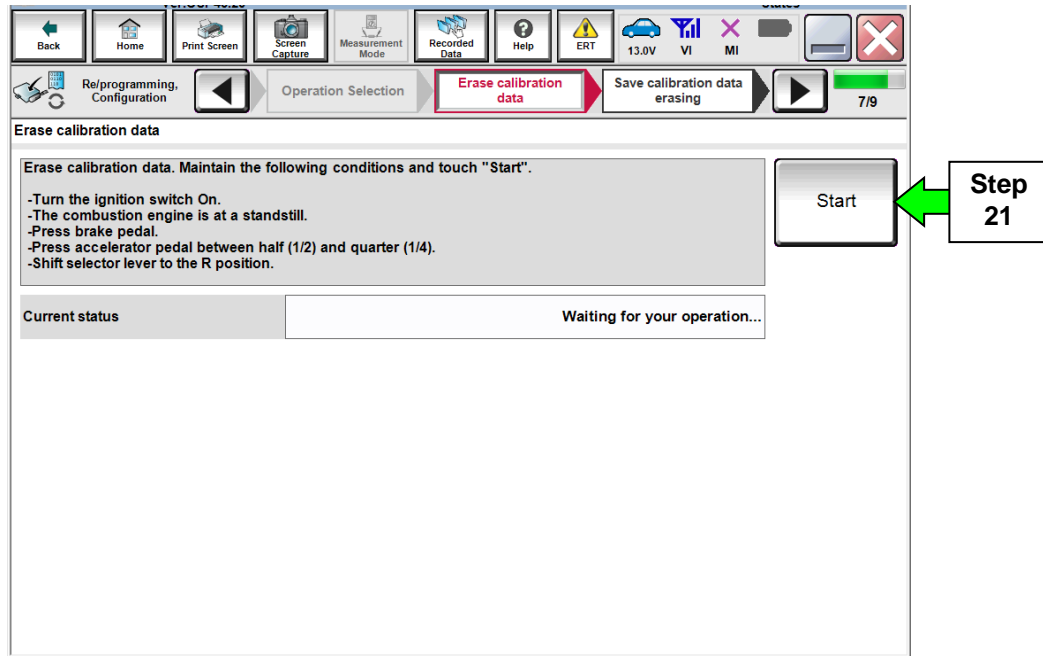

Figure 9

22. When **COMPLETED** is displayed, select **Next**.

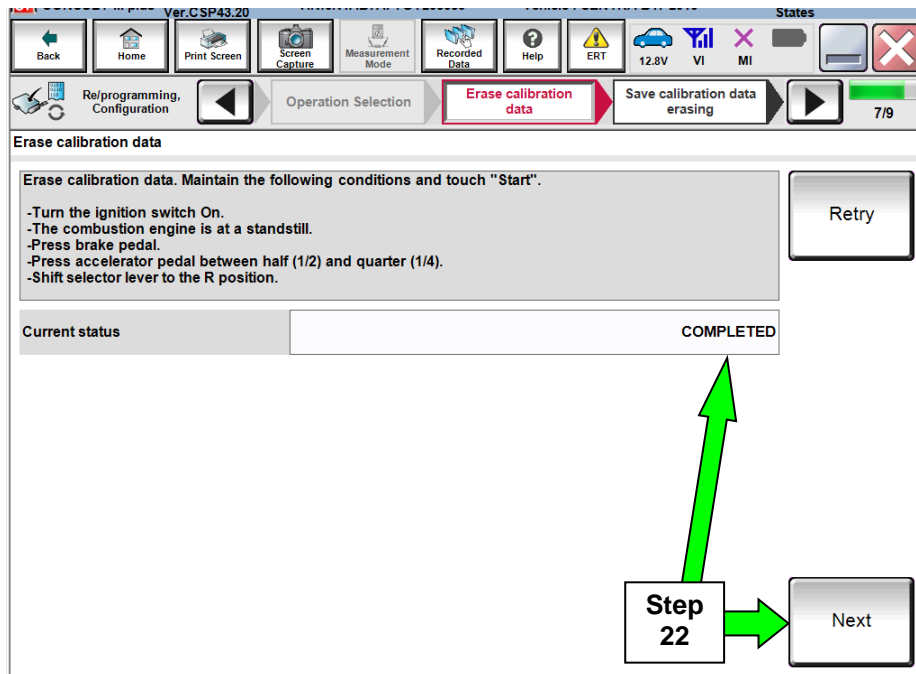

Figure 10

23. Operate the ignition per the on screen instructions.

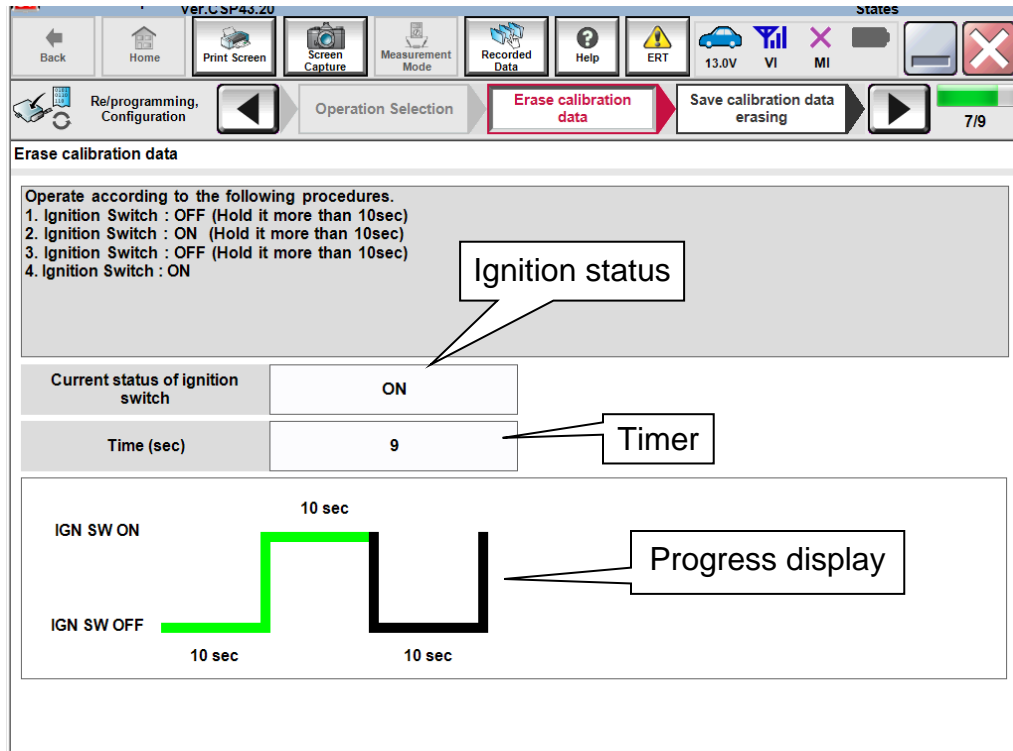

Figure 11

24. When OK is displayed, select **Next**.

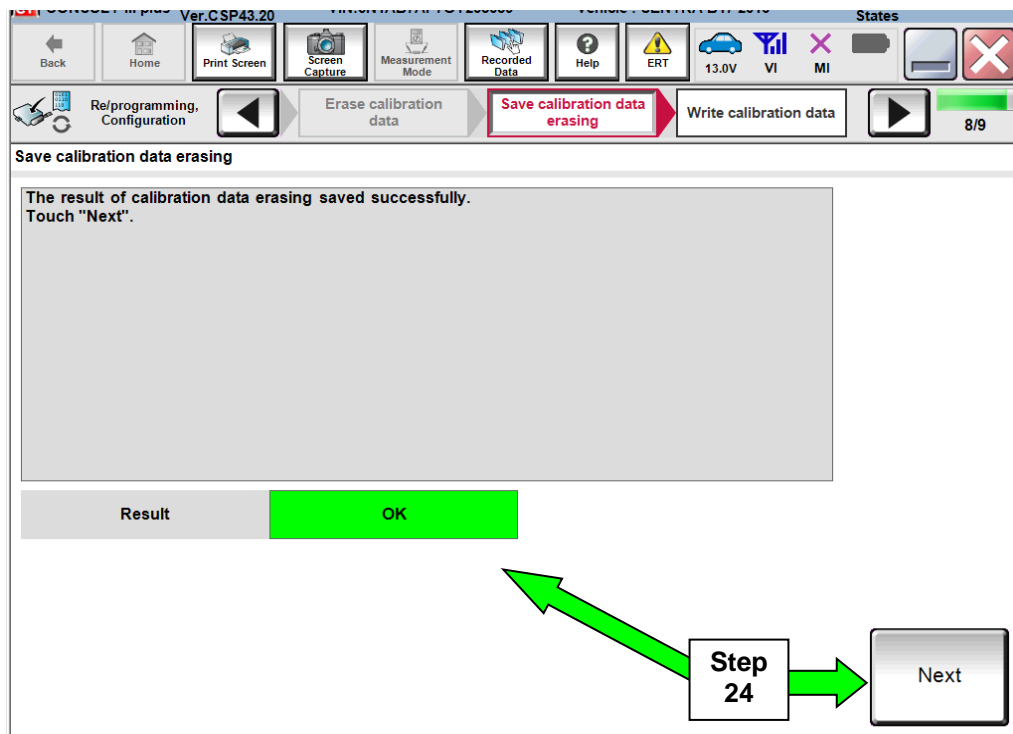

Figure 12

25. Move the shift selector to P, then select **Next**.

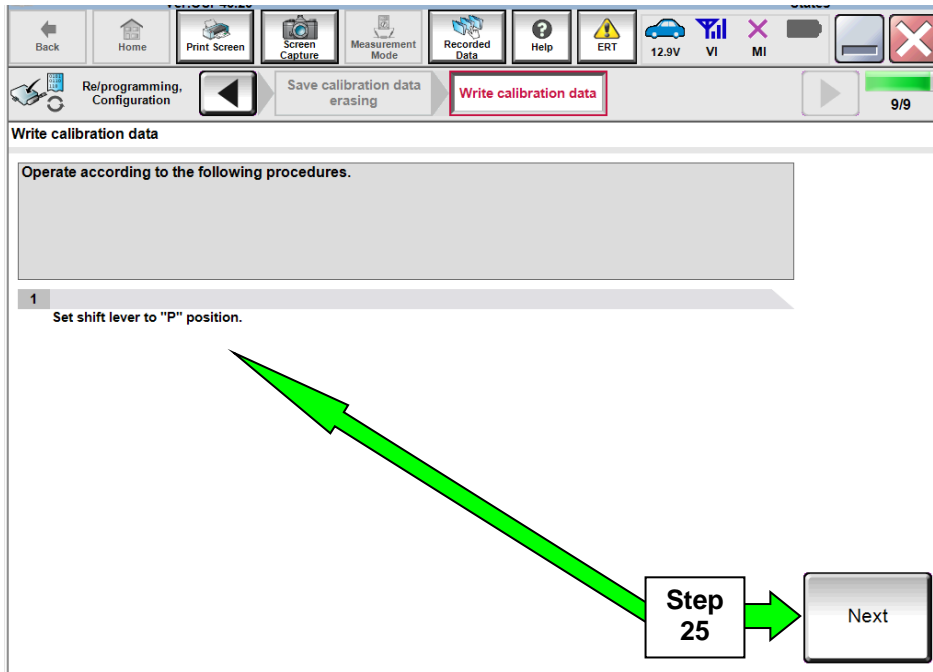

Figure 13

26. Operate the shift selector per the on-screen instructions.

- a. Move the shift selector; P>R>N>D>P
- b. Confirm the center display meter indicates the correct selector position.

27. Select **Next**.

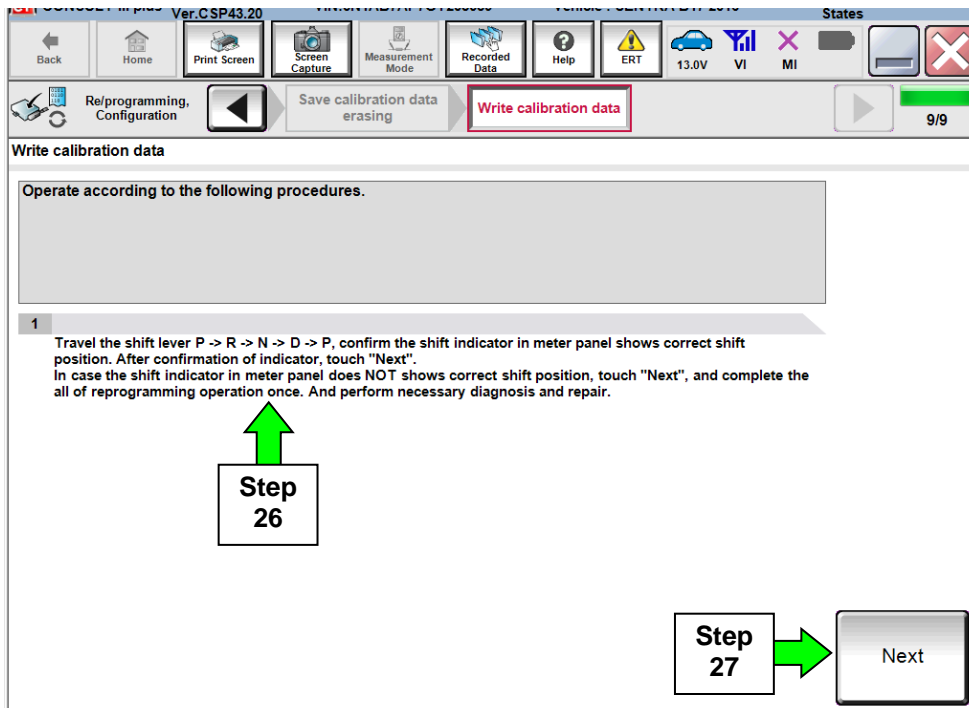

Figure 14

28. Find the TCM **Part Number** (see Figure 15) and write it on the repair order.

**NOTE:** This is the current Part Number (P/N).

29. Compare the P/N you wrote down to the numbers in the **Current TCM Part Number** column in **Table A** below.

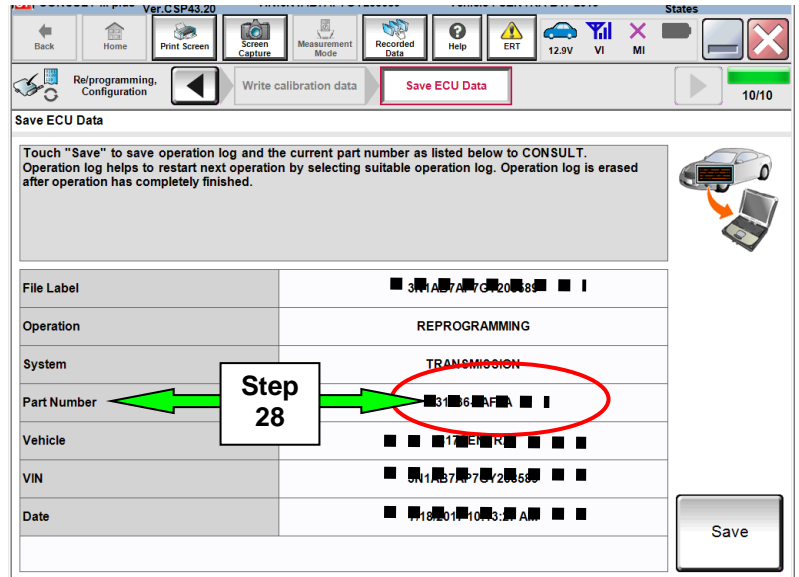

Figure 15

30. Comparison results:

- If there is a match, continue with the reprogramming procedure.
- If there is not a match, reprogramming is not needed. Skip to **ERASE MEMORY DATA** on page 29.

Table A

MODEL	MODEL YEAR	CURRENT TCM PART NUMBER: 31036 -
Sentra	2013	3SG0A, 3SG0B, 3SG0C, 3SG9B, 3SG9C, 3SR0A, 3SR0B, 3SR0C, 3SR9B, 3SR9C
	2014	9AM2A, 9AM2B, 9AM2C, 9AM9B, 9AM9D, 9AM9E
	2015	4AT0A, 4AT0B, 4AT0C, 4AT0D, 4AT9A, 4AT9D, 4AT9E
	2016	4AF6A, 4AF6B, 4AF9D
	2017	4FY0A, 4FY0B, 4FY0C
Versa Sedan	2013	9KB1B, 9KB1C, 9KB1D, 9KB9E, 9KJ9E
	2014	3BE0A, 3BE0B, 3BE9A, 3BE9C
	2015	9KE0A, 9KE0B, 9KE0C, 9KE9C, 9KE9E
	2016	9KN0A, 9KN0B, 9KN0C, 9KN8D, 9KN8E
	2017	9KN2A, 9KN2B, 9KN2C
Versa NOTE	2014	3VB2A, 3VB2B, 3VB2C, 3VB8C, 3VB9D
	2015	3VB6A, 3VB9A, 3VB9B, 3VB9C, 3VB9E, 3WC9D
	2016	3VB4A, 3VB4B, 3VB4C, 3VB4D, 3VB7A, 3WC9E
	2017	9ME0A, 9ME0B, 9ME0C

31. Select **Save**.

32. Use arrows (if needed) to view and read all precautions.
33. Check the box confirming the precautions have been read.
34. Select **Next**.

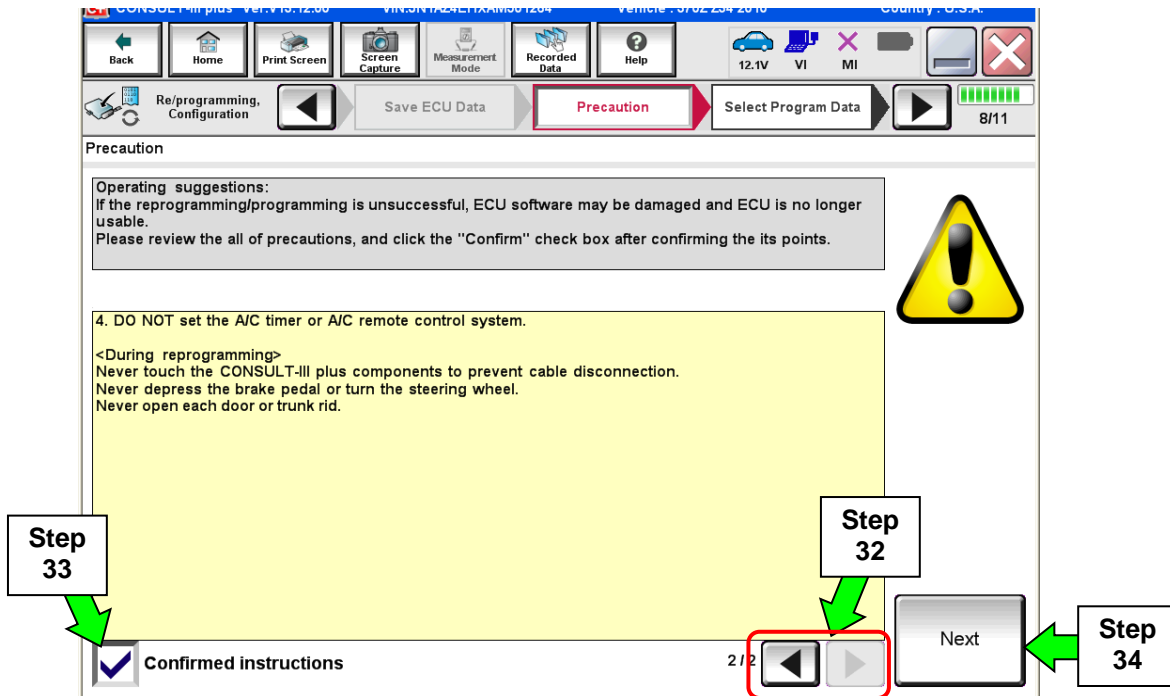

Figure 16

**NOTE:** If you get the screen in Figure 17 and it is blank (no reprogramming listed), it means there is no reprogramming available for this vehicle. Close C-III plus and refer back to ASIST for further diagnosis.

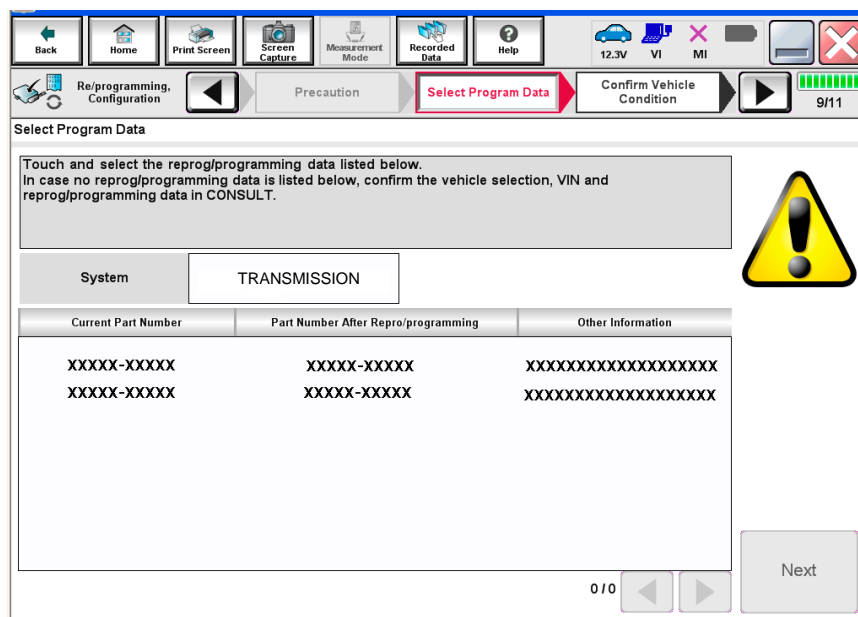

Figure 17



35. Read the **Current Part Number** and **Part Number After Reprogramming**. They should be different.

36. Select **Next**.

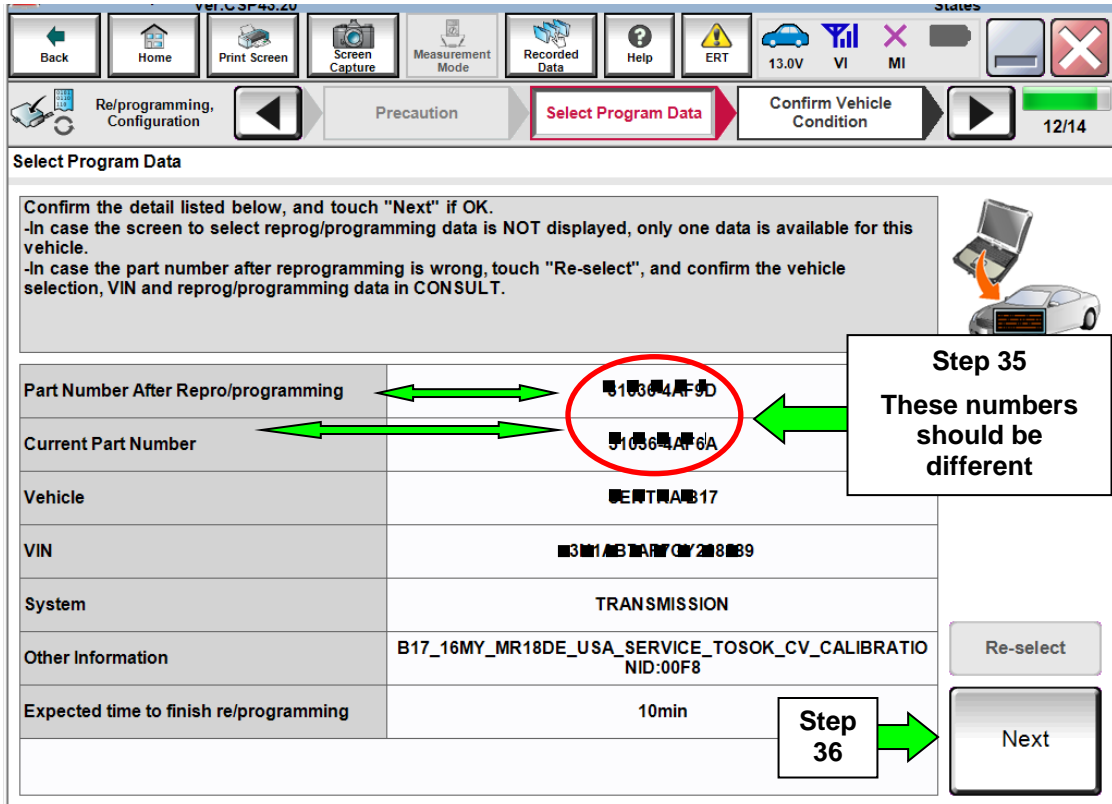

Figure 17a

37. Make sure **OK** is highlighted **green** (battery voltage must be between **12.0** and **15.5 Volts**).

38. Select **Next**.

**IMPORTANT:** Battery voltage must stay between **12.0** and **15.5 Volts** during reprogramming or TCM reprogramming may be interrupted and TCM may be damaged.

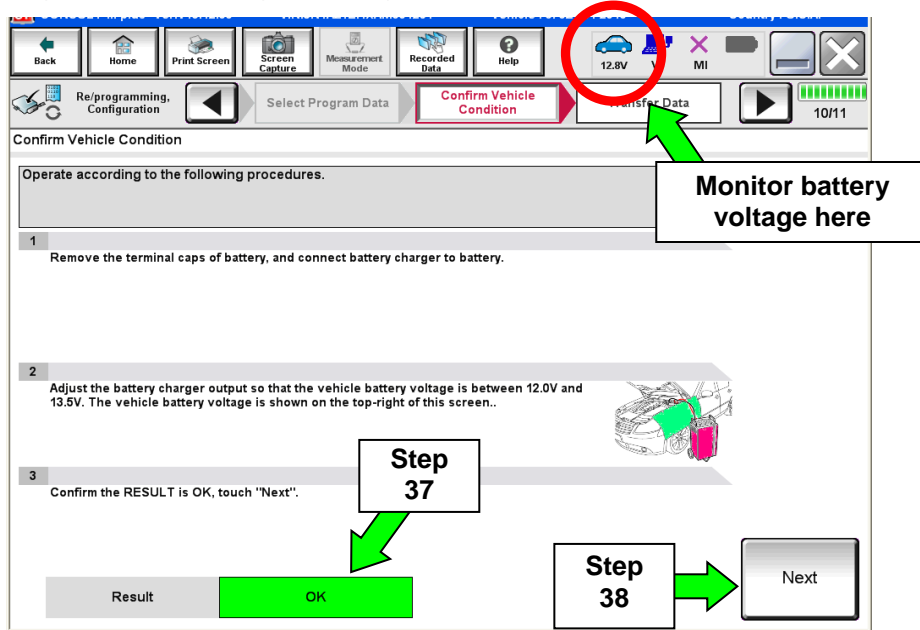

Figure 18

39. Make sure **OK** is highlighted **green** for all Judgements then select **Start**.

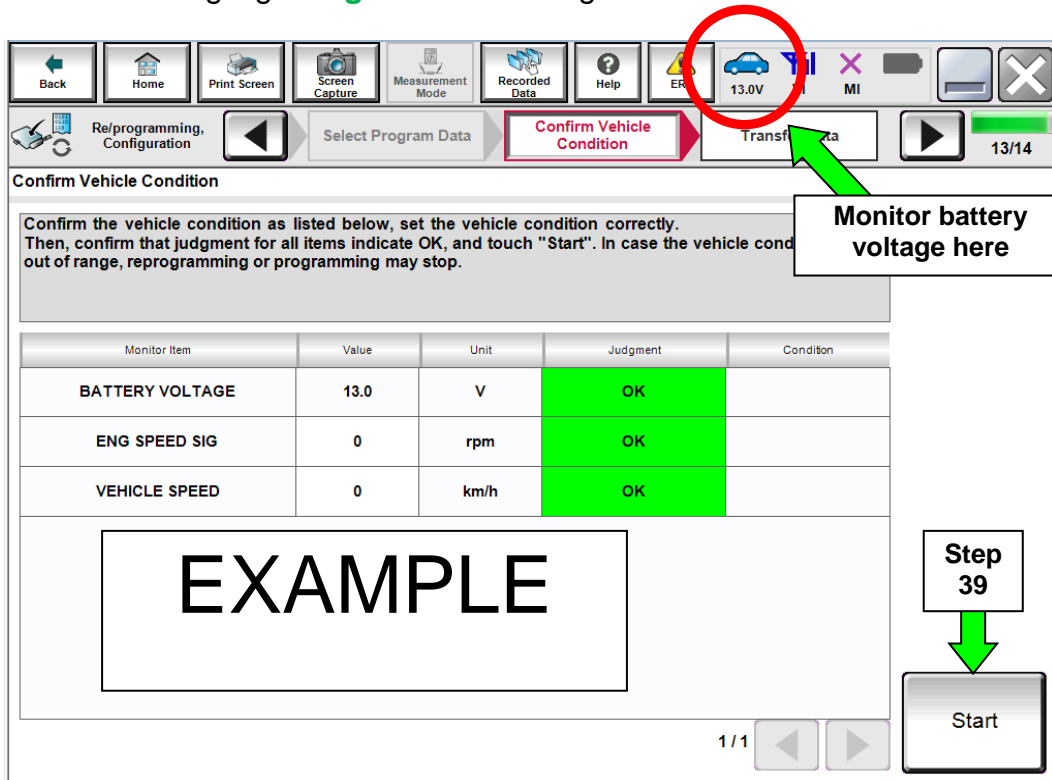

Figure 19

40. Select **USA/CANADA Dealers**.

41. Select **OK**.

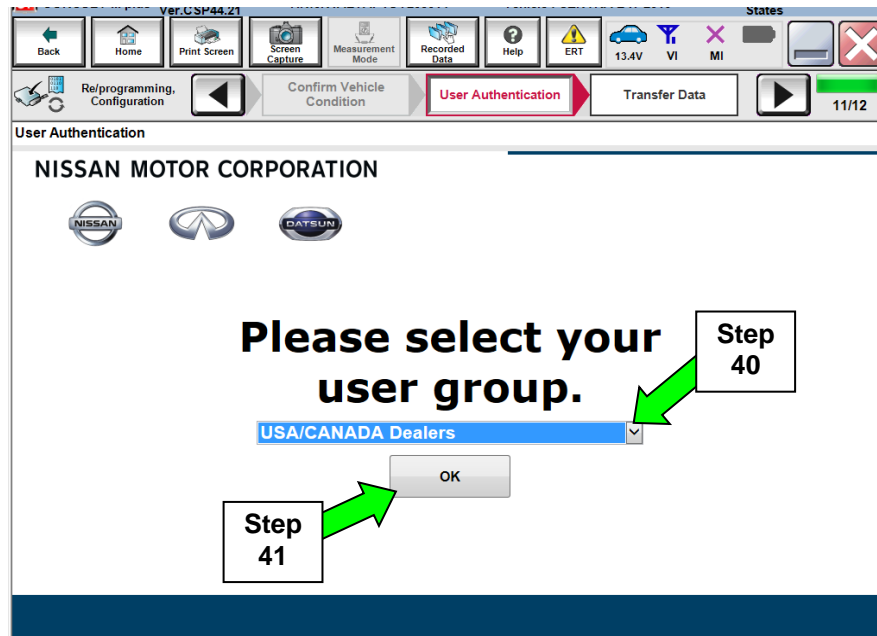

Figure 20

**NOTE:**

- The above screen may not display if the CONSULT PC has remained ON since the last reprogramming.
- If the CONSULT PC is not connected to the Internet, the screen in Figure 21 will display.

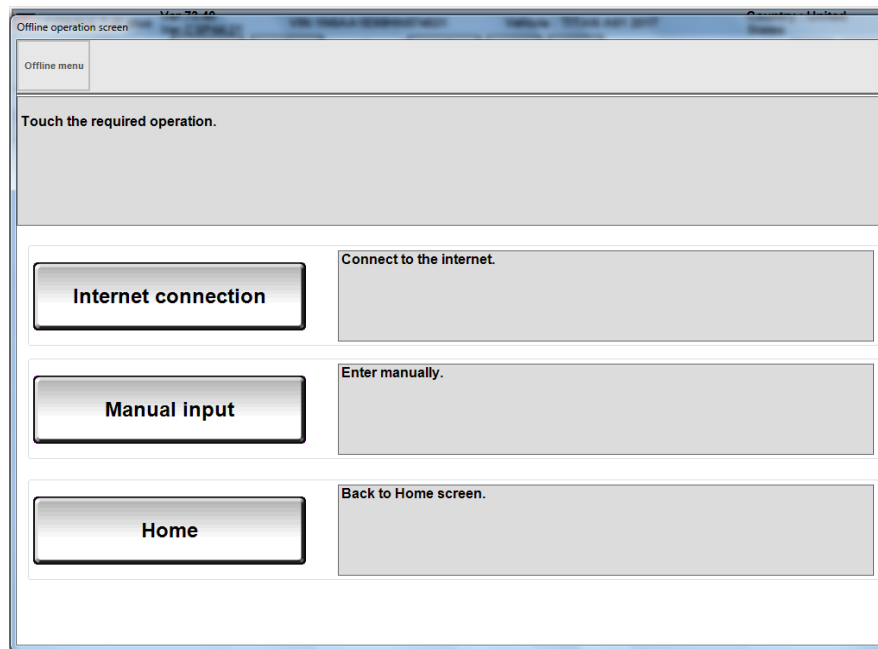

Figure 21

## 42. Enter Username and Password.

- Before reprogramming will start, you will be required to enter your User Name and Password.
- The CONSULT PC must be connected to the Internet (Wi-Fi or cable).
  - If you do not know your User Name and Password, contact your Service Manager.

## 43. Select **Submit**.

- There will be a short pause while the username and password are authenticated.
- Once authentication completes, TCM reprogramming will automatically begin and the screen in Figure 23 on the next page will be displayed.

The screenshot shows the CONSULT PC software interface. At the top, there is a toolbar with icons for Back, Home, Print Screen, Screen Capture, Measurement Mode, Recorded Data, Help, ERT, 14.7V, VI, MI, and States. Below the toolbar, there is a progress bar with '11/12' and a 'User Authentication' button. The main content area is titled 'User Authentication' and features the SecureAuth logo and 'Daimler WS'. The form prompts the user to 'Please enter your UserID below.' and includes input fields for 'Username:' and 'Password:'. A 'Submit' button is located below the input fields. A green arrow points from a box labeled 'Step 42' to the Username field, and another green arrow points from a box labeled 'Step 43' to the Submit button. At the bottom of the screen, there is a 'Restart Login' link and a 'Powered by SECUREAUTH' logo. The footer text reads 'Copyright 2015 SecureAuth Corp. All rights reserved.'

Figure 22

44. Wait for both progress bars to complete.

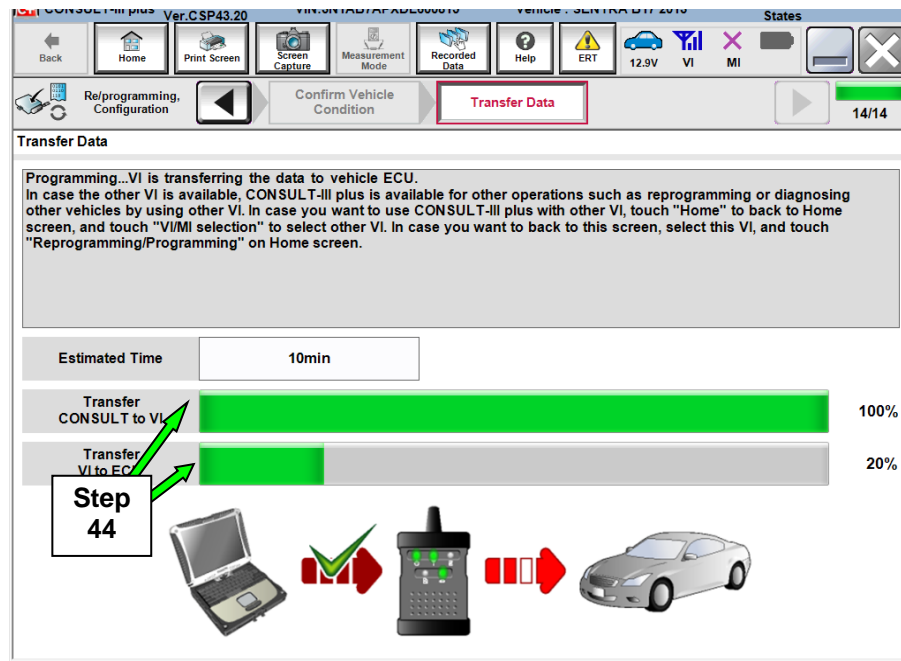

Figure 23

45. When the screen in Figure 24 displays, the reprogramming is complete.

**NOTE:** If the screen in Figure 24 does not display (which indicates reprogramming did not complete), refer to the information on the next page.

46. Disconnect the battery charger (GR8) from the vehicle.

47. Select **Next**.

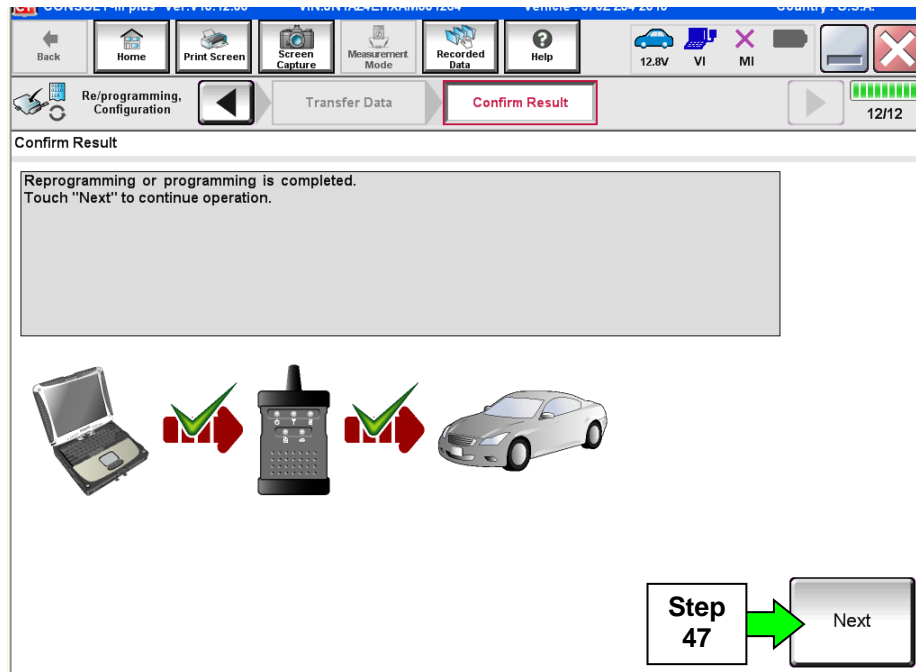

Figure 24

**NOTE:** Additional steps/operations are required before C-III plus will provide the final reprogramming confirmation report. Continue with the reprogramming procedure on page 23.

If reprogramming does not complete and the “!” symbol displays as shown in Figure 25:

- Check battery voltage (12.0 – 15.5V).
- Ignition ON, engine OFF.
- External Bluetooth® devices are OFF.
- All electrical loads are OFF.
- **Select Retry and follow the on screen instructions.**

**NOTE:** Retry may not go through on first attempt and can be selected more than once.

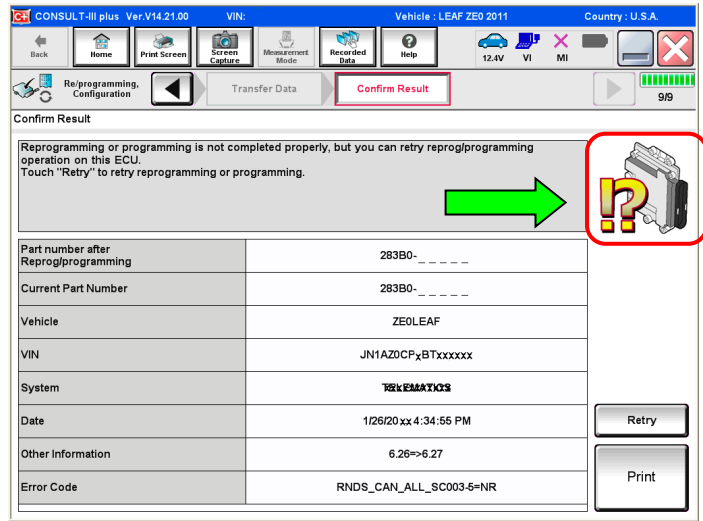

Figure 25

If reprogramming does not complete and the “X” symbol displays as shown in Figure 26:

- **Do not disconnect the plus VI or shut down C-III plus if reprogramming does not complete.**
- Check battery voltage (12.0 – 15.5V).
- CONSULT A/C adapter is plugged in.
- Ignition ON, engine OFF.
- Transmission in Park.
- All C-III plus / plus VI cables are securely connected.
- All C-III plus updates are installed.
- **Select Home, and then restart the reprogram procedure from the beginning.**

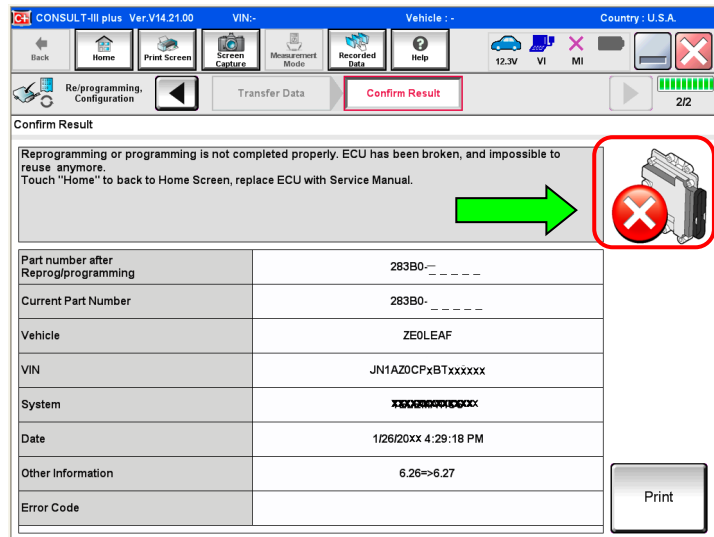

Figure 26

48. Confirm the Transmission Fluid temperature judgment is **OK**, then select **Next**.

- If the judgment is NG, drive the vehicle to warm the transmission until the judgment changes to OK.

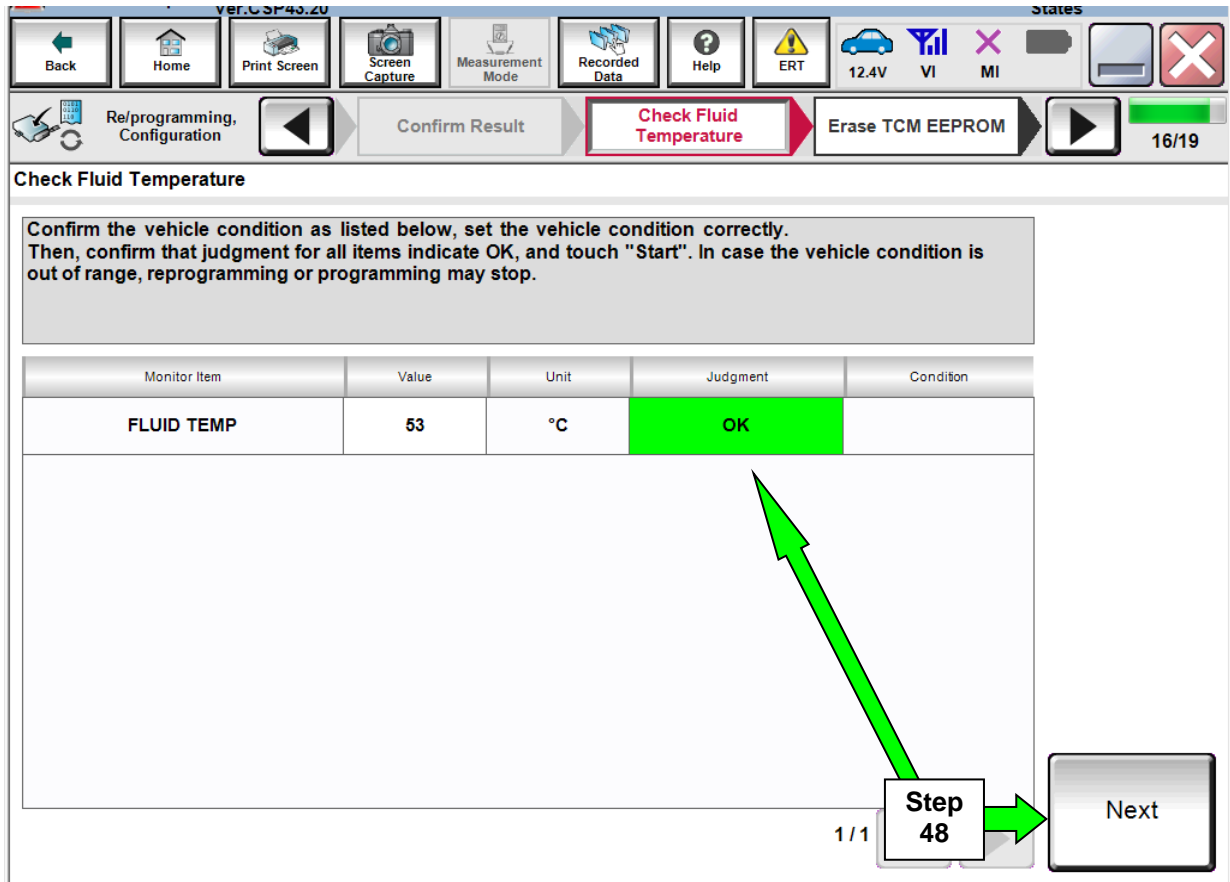

Figure 27

49. Follow the on-screen instructions; maintain the following conditions:

- a. Parking brake set.
- b. Ignition ON, with the engine OFF.
- c. Press the Brake.
- d. Press accelerator between  $\frac{1}{4}$  and  $\frac{1}{2}$ .
- e. Put shift selector in R.

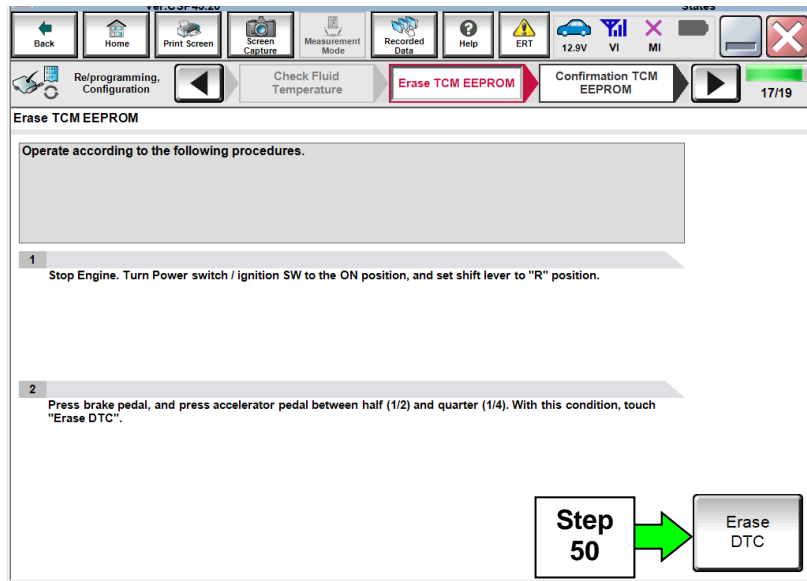

Figure 28

50. Select **Erase DTC**.

51. Follow the on-screen instructions; maintain the following conditions:

- a. Parking brake set.
- b. Ignition ON, with the engine OFF.
- c. Fully depress the accelerator.
- d. Put shift selector in R.

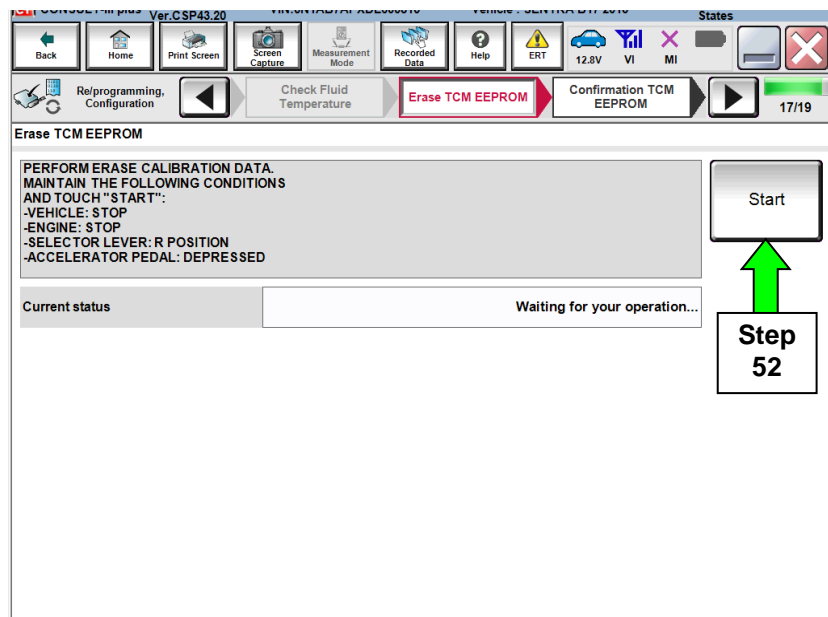

Figure 29

52. Select **Start**.



53. When **COMPLETED** is displayed, select **Next**.

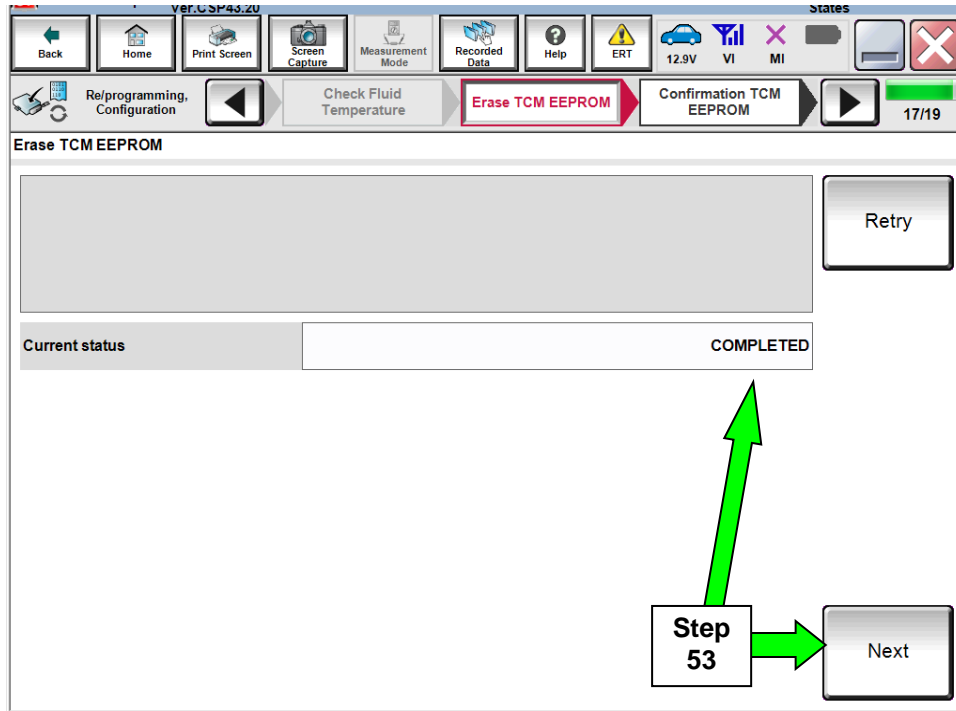

Figure 30

54. Operate the ignition per the on-screen instructions.

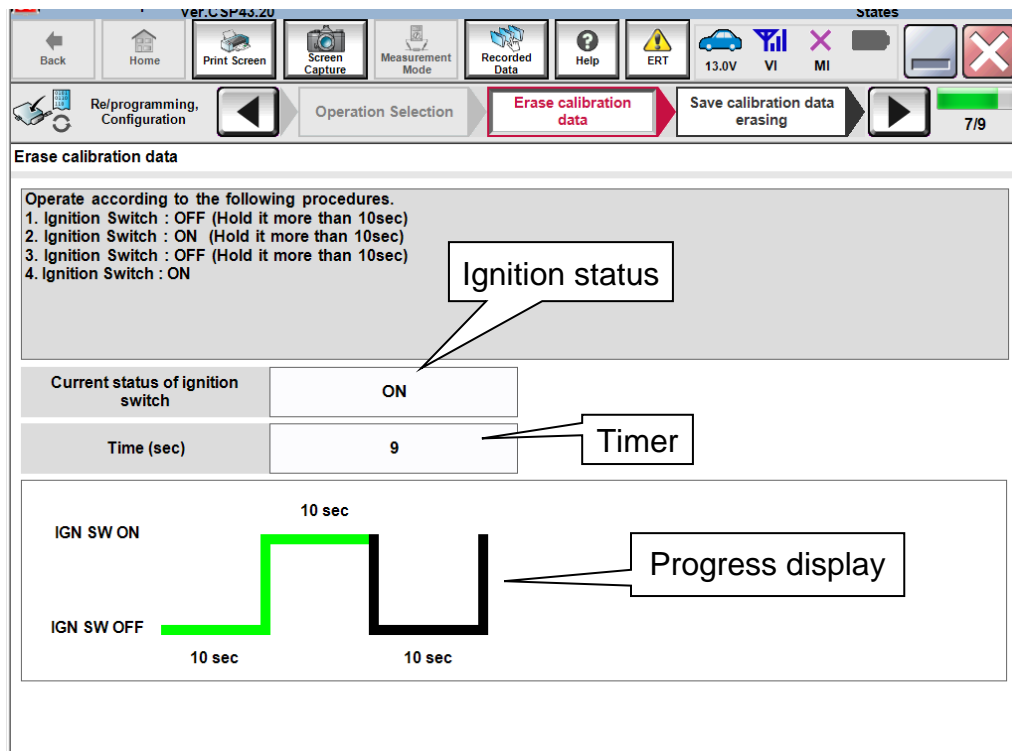

Figure 31

55. When **OK** is displayed, select **Next**.

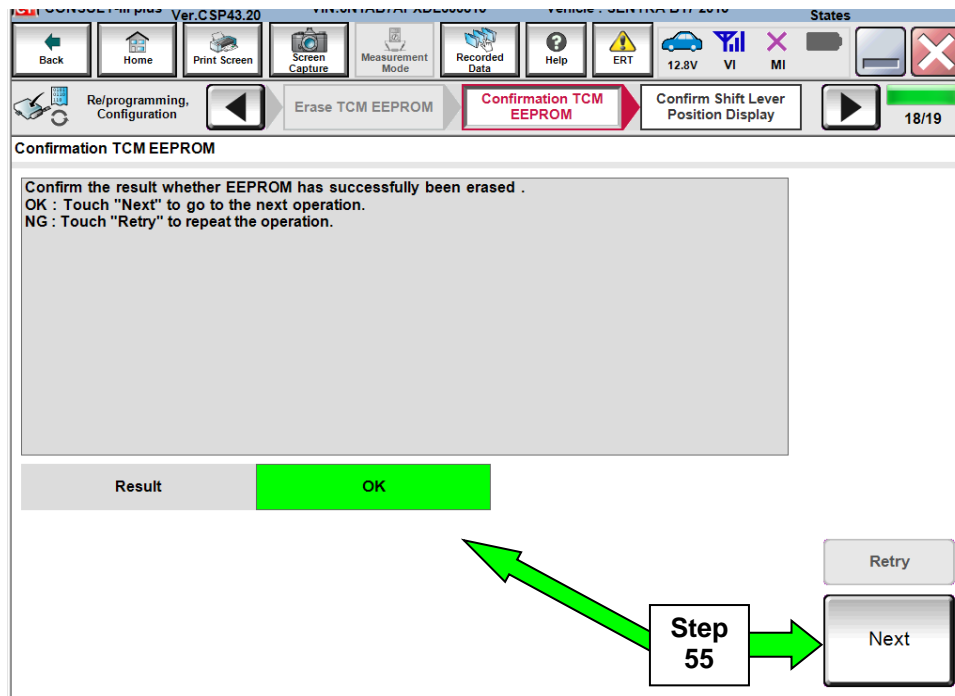

Figure 32

56. Operate the shift selector per the on-screen instructions.

- Move the shift selector to P; then move P>R>N>D>P
- Confirm the center display meter indicates the correct selector position.

57. Select **Next**.

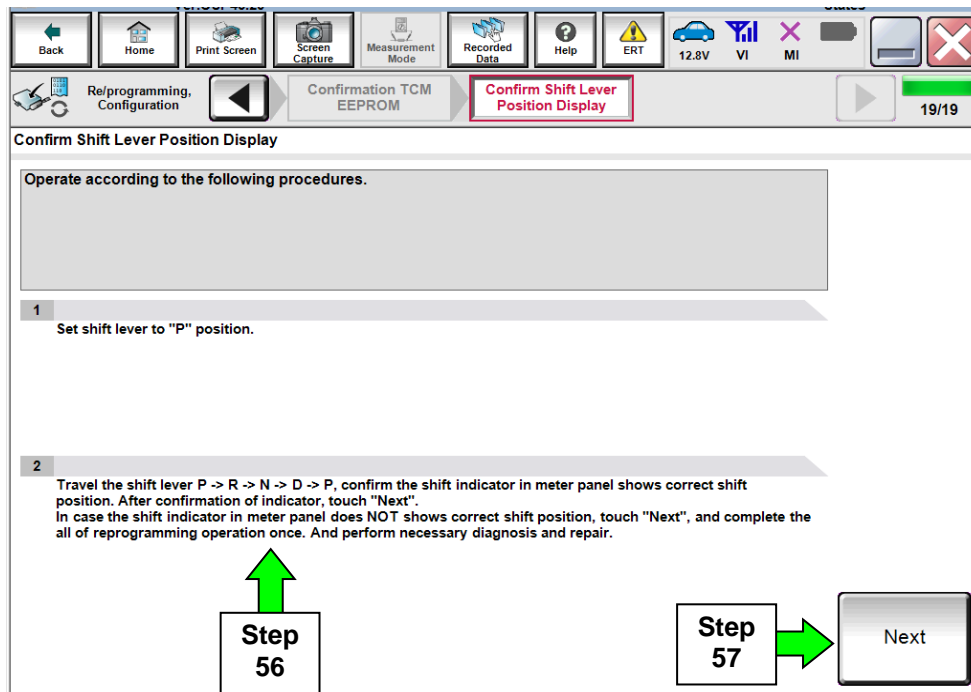

Figure 33

58. Erase all DTCs as follows:

- a. Turn the ignition OFF.
- b. Turn the Ignition ON.
- c. Wait for DTC erase to complete.

59. Select **Next**.

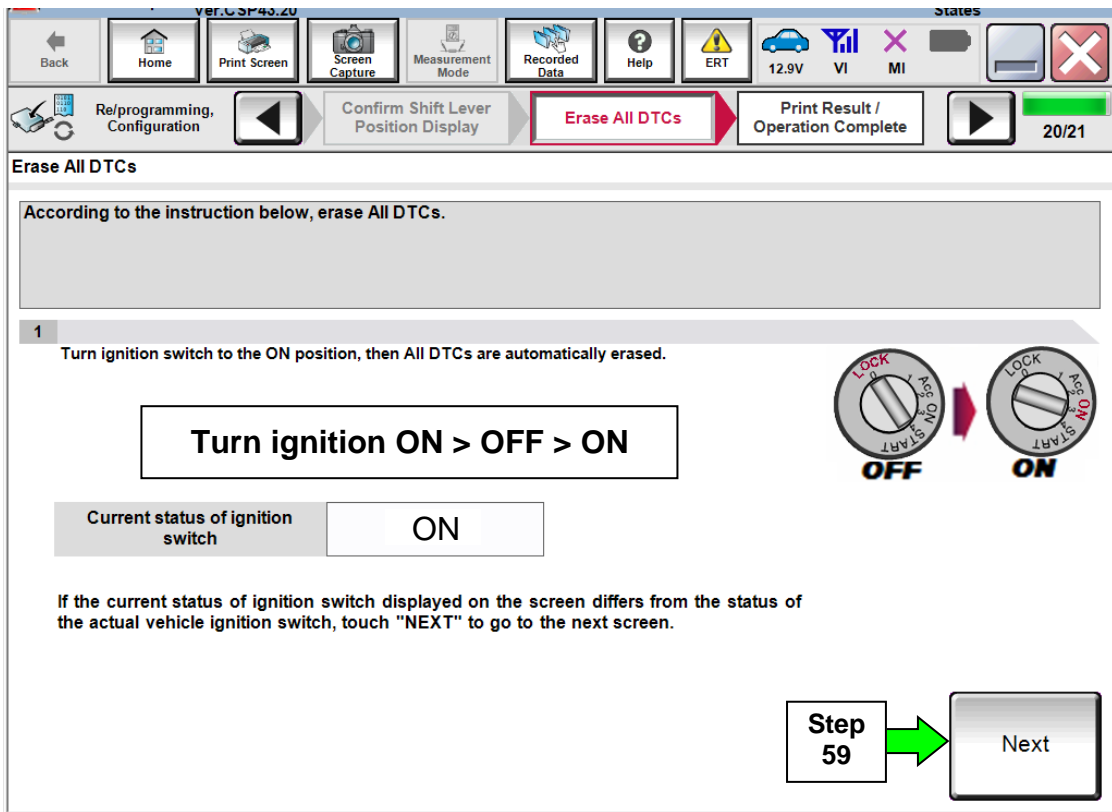

Figure 34

60. Verify the before and after part numbers are different.

61. Print a copy of this screen (Figure 35) and attach it to the repair order.

62. Select **Confirm**.

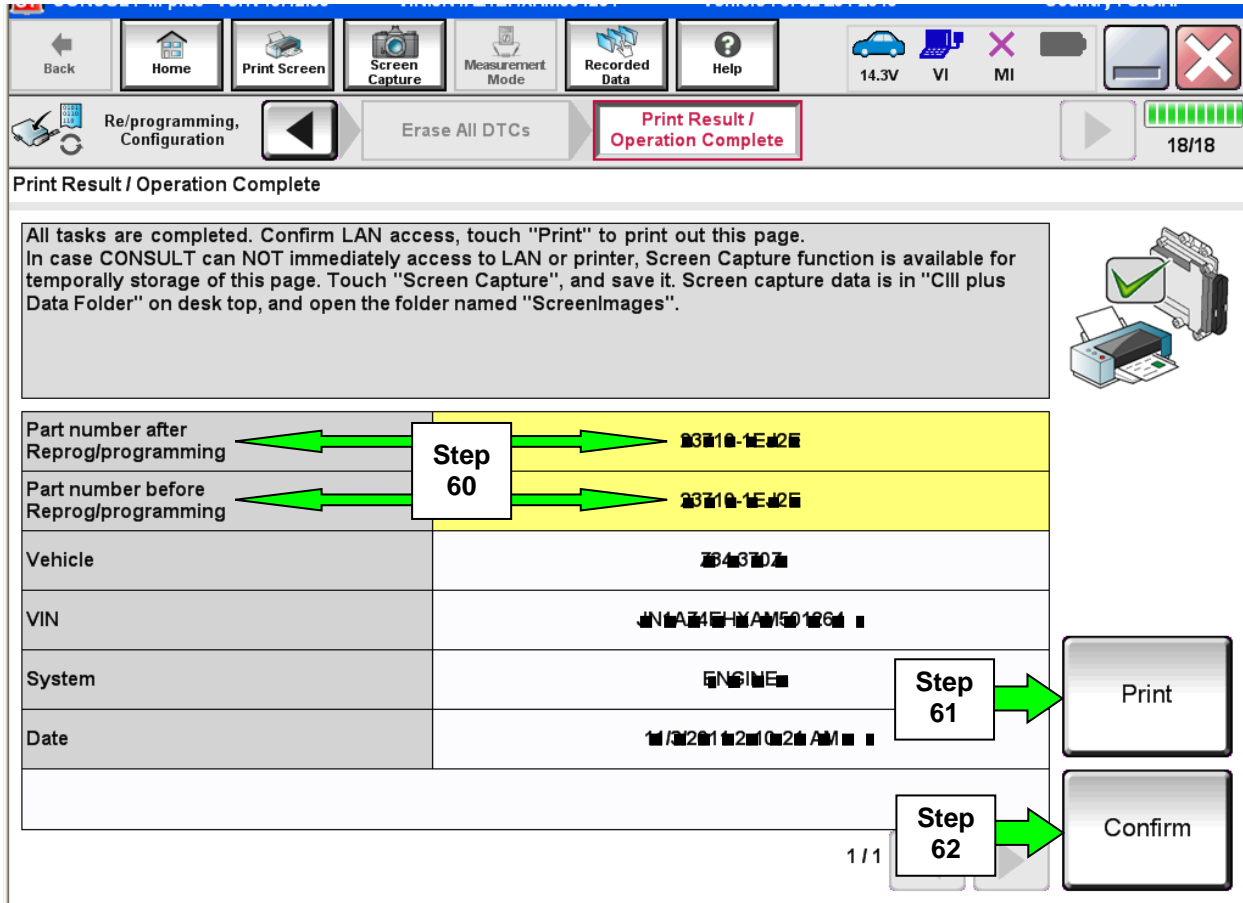

Figure 35

**NOTE:** If you cannot print the above screen:

- Select Screen Capture.
  - Name the file.
  - Save the file in My Documents.
- A copy of the screen is now saved in the CONSULT PC. It can be retrieved and printed at a later time.

## ERASE MEMORY DATA

**NOTE:** This procedure is for all Applied Vehicles.

63. Navigate C-III plus to the screen shown in Figure 36.

- **Diagnosis (All Systems) > TRANSMISSION > Work support**

64. Select **ERASE MEMORY DATA**.

65. Select **Start**.

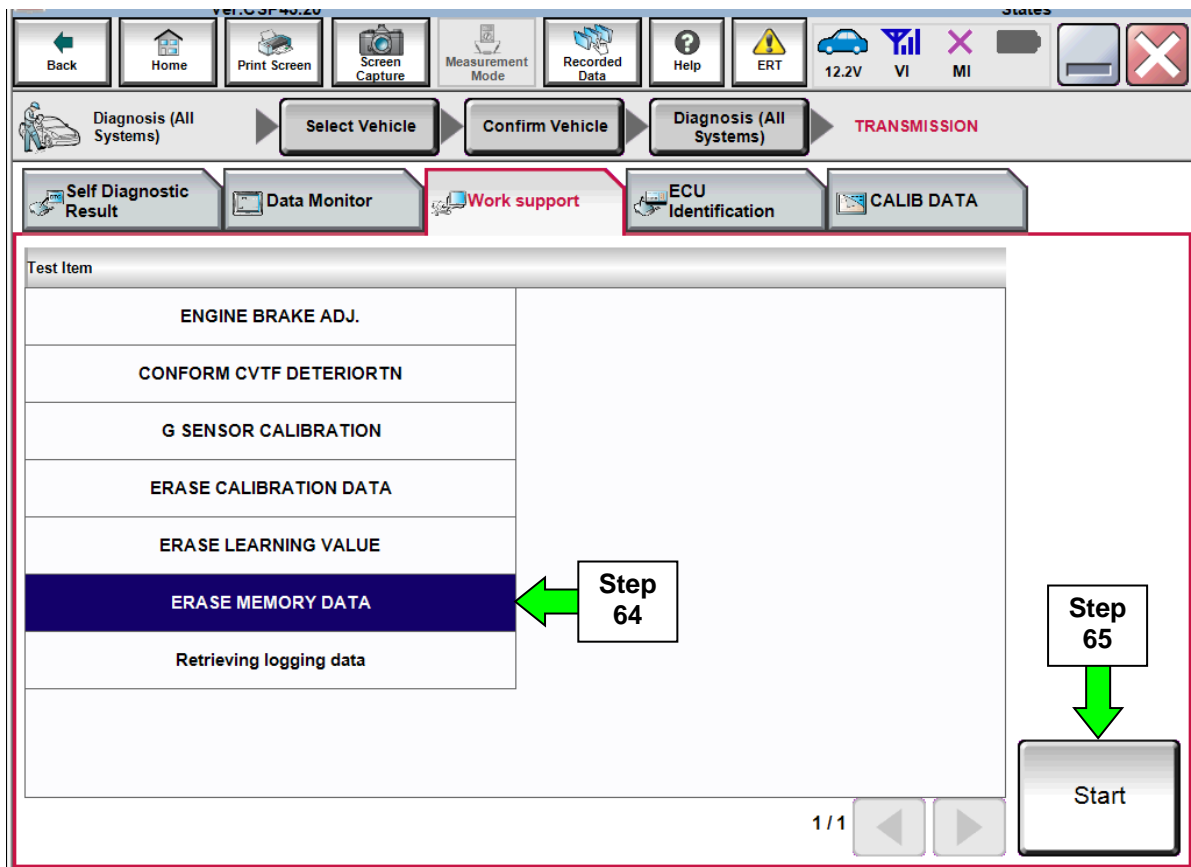

Figure 36

66. Follow the on-screen instructions; maintain the following conditions:
- Parking brake set.
  - Ignition ON, with the engine OFF.
  - Fully depress the accelerator.
  - Put shift selector in R.

67. Select **Start**.

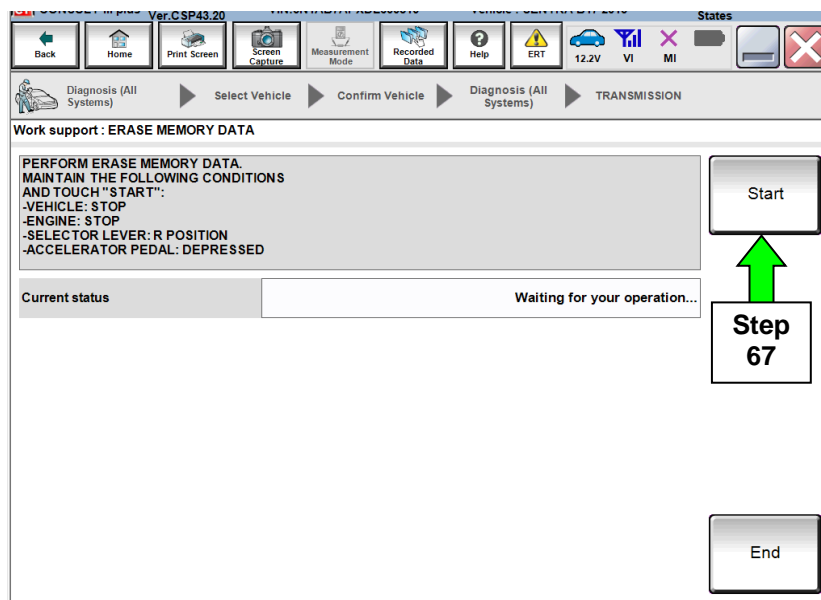

Figure 37

68. When the Current status changes to COMPLETED, select **End**.

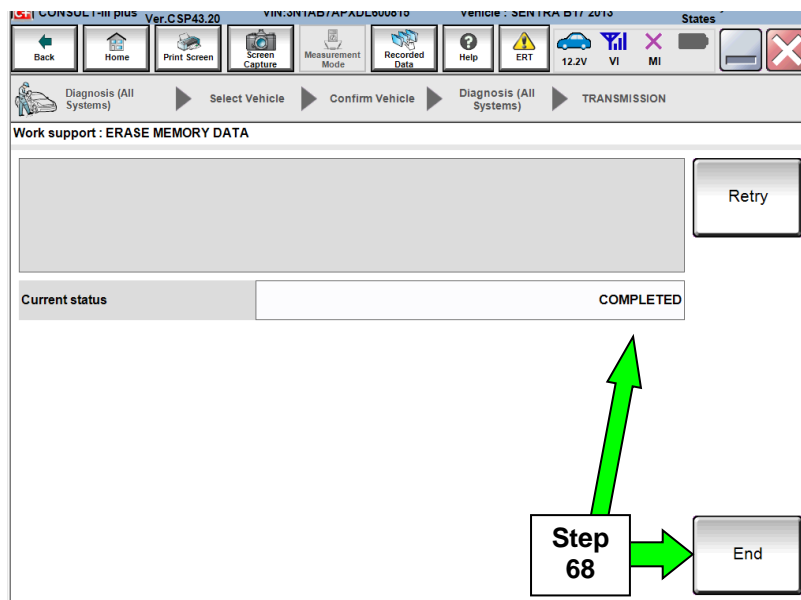

Figure 38

69. Move the shift selector to P, and then turn the ignition OFF.

70. Turn the ignition ON, and then confirm P and N display by moving the shift selector in those positions.

## CONFORM CVTF DETERIORTN

**NOTE:** This procedure is for all Applied Vehicles.

71. Navigate C-III plus to the screen shown in Figure 39.

- **Diagnosis (All Systems) > TRANSMISSION > Work support**

72. Select **CONFORM CVTF DETERIORTN**.

73. Select **Start**.

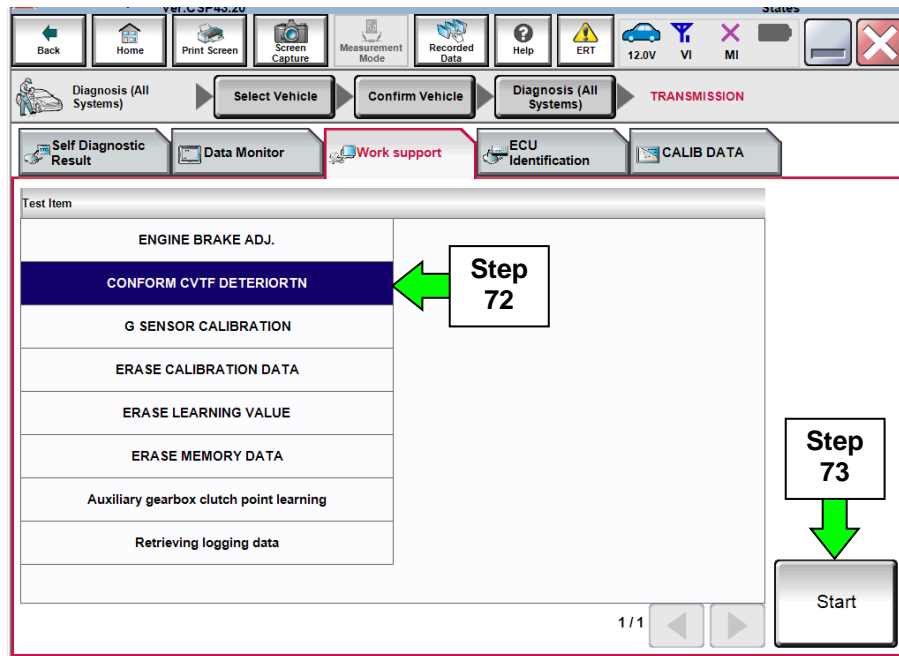

Figure 39

74. Select **Start**.

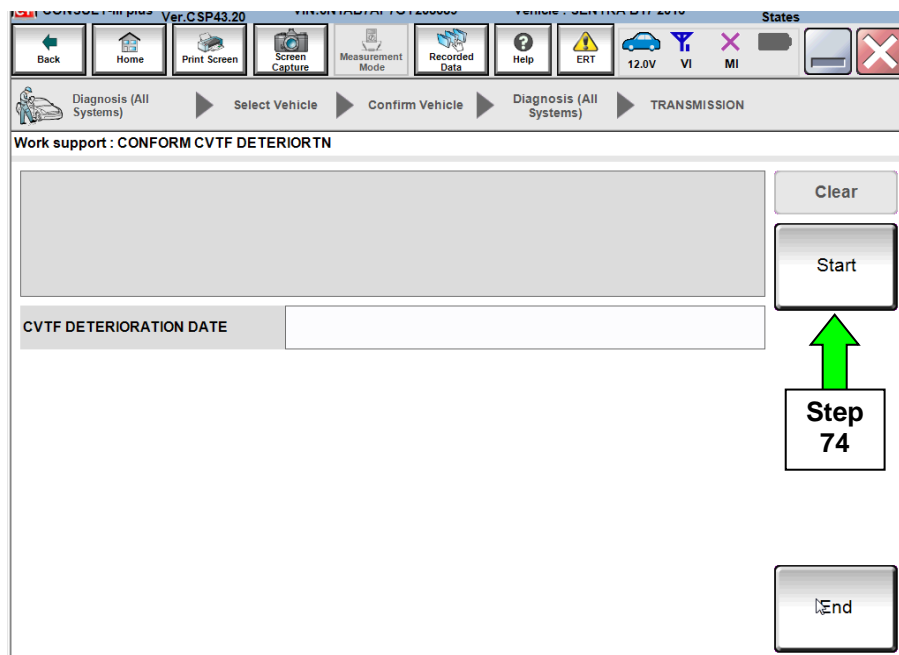

Figure 40

75. Select **Clear**.

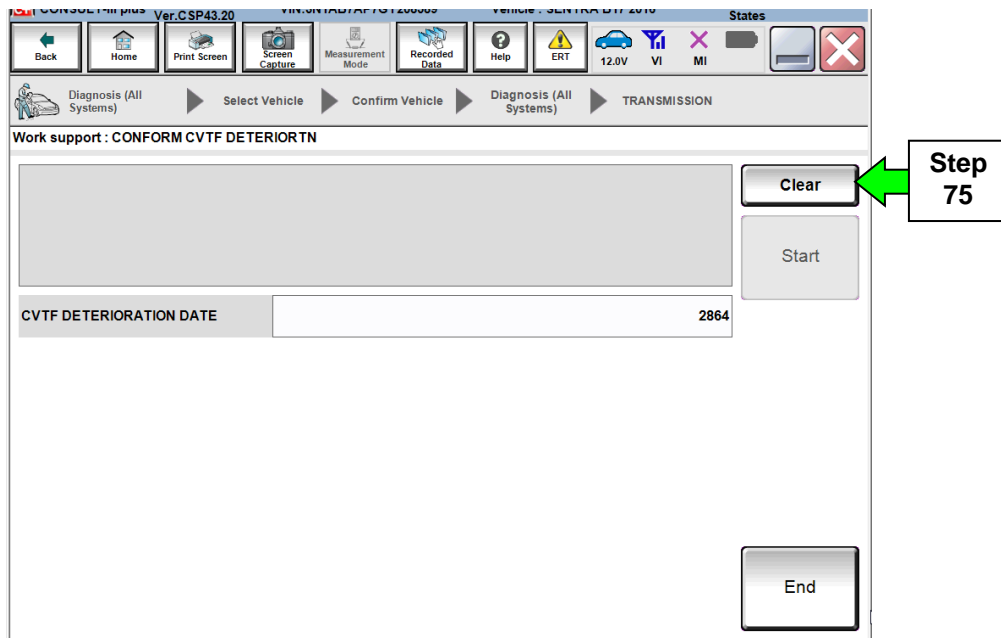

Figure 41

76. Select **Yes**.

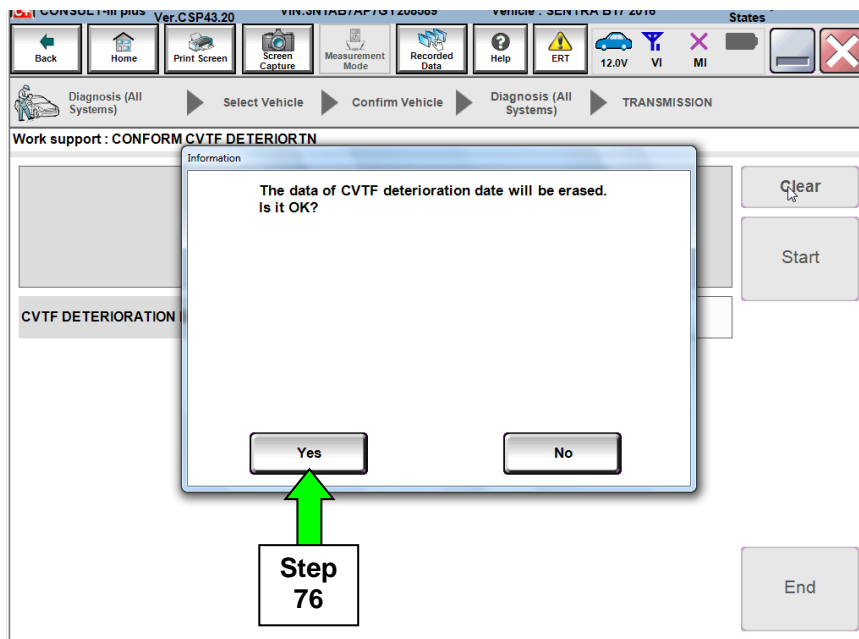

Figure 42



77. When **CVTF DETERIORATION DATE** changes to “0”, select **End**.

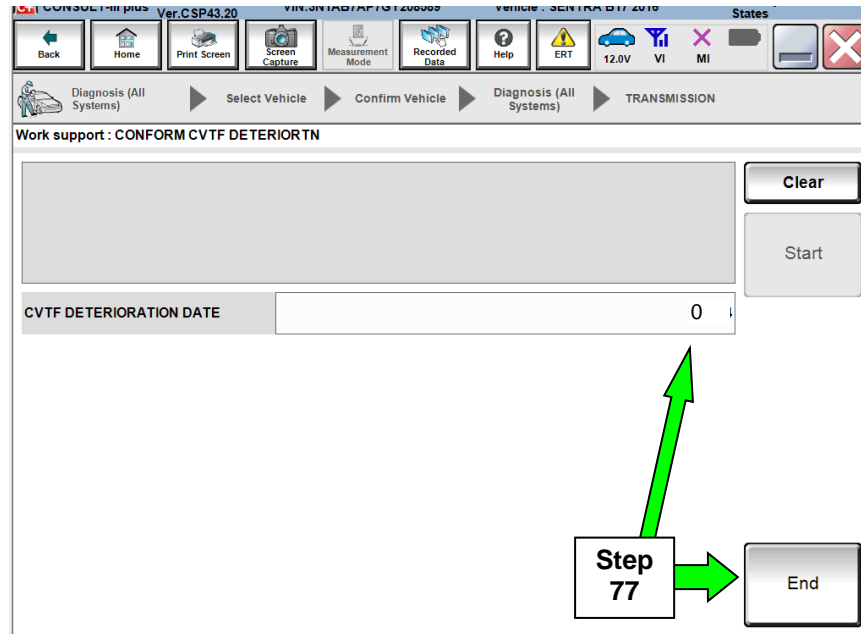

Figure 43

78. Start the engine.

79. Set the parking brake.

80. Turn OFF the A/C.

81. Bring the engine to normal operating temperature range.

82. Confirm the CVT fluid temperature is over 122°F (50°C).

## Auxiliary gearbox clutch point learning

**NOTE:** This procedure is for all Applied Vehicles.

83. Navigate C-III plus to the screen shown in Figure 44.

- **Diagnosis (All Systems) > TRANSMISSION > Work support**

84. Select **Auxiliary gearbox clutch point learning**.

Or

- If this feature is not available in the vehicle that is being repaired, skip to **Manual Auxiliary gearbox clutch point learning on page 38**.

85. Select **Start**.

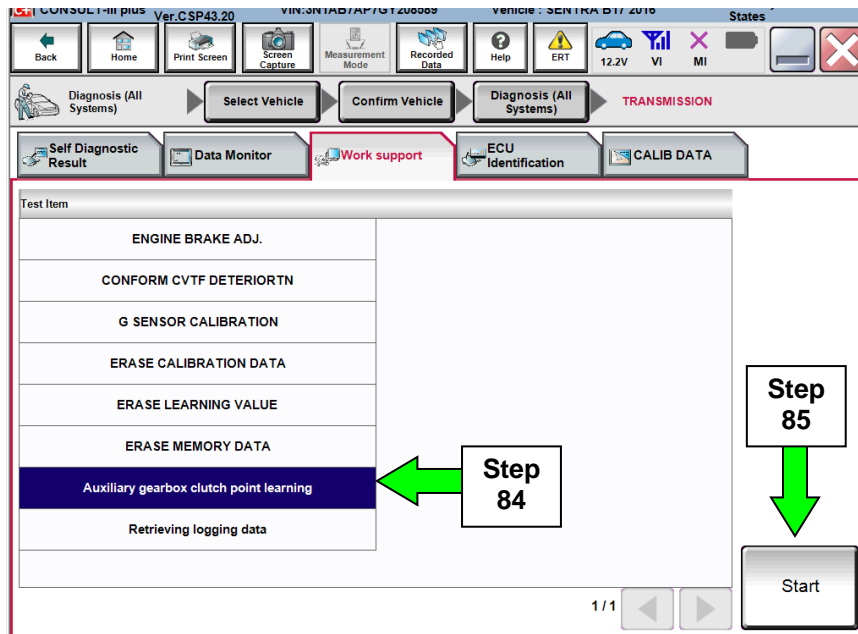

Figure 44

86. Follow the on-screen instructions in Figure 45, and then select **Start**.

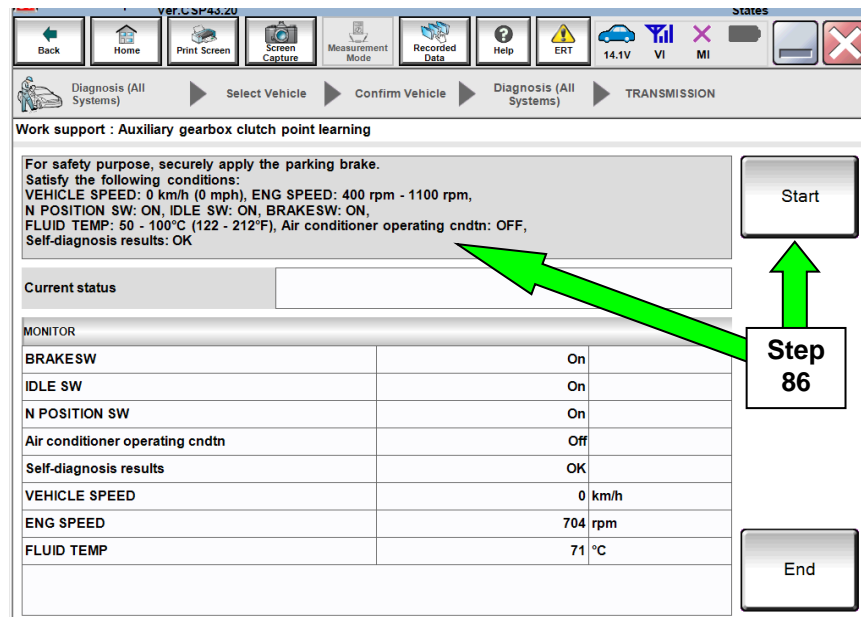

Figure 45

87. With the brake pedal still applied, shift the CVT selector lever into the D position.

- Figure 46 (below) will be displayed after shifting into D position.

**NOTE:** The Current status will show EXECUTING (Figure 46), but until the vehicle is shifted into the D position, Auxiliary gearbox clutch point learning will not begin.

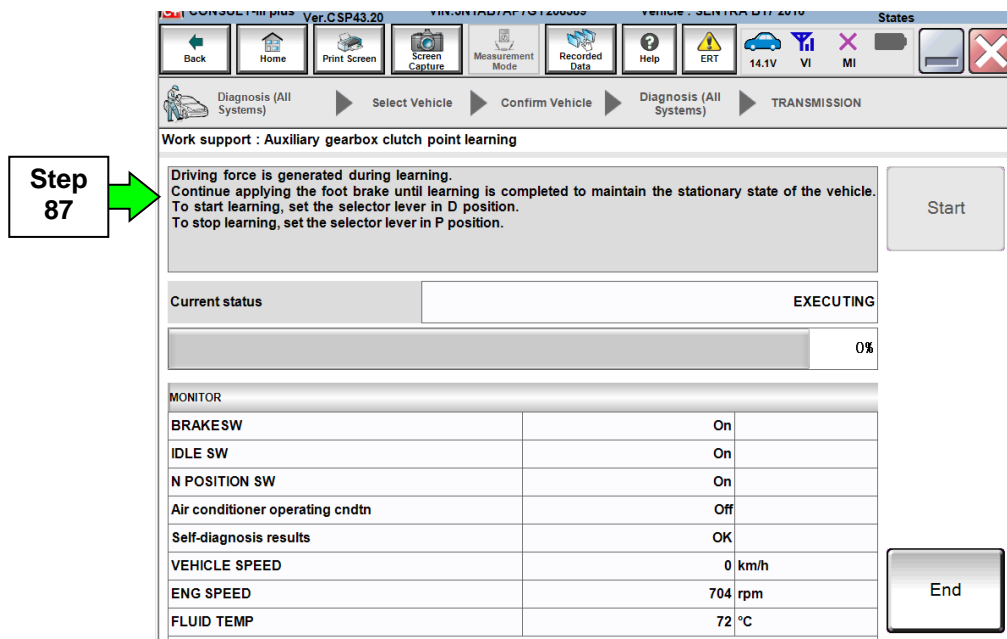

Figure 46

88. Continue to depress the brake pedal until the **Current status** shows “Completed” as shown in Figure 48 at the bottom of this page.

**NOTE:** This may take several minutes to complete.

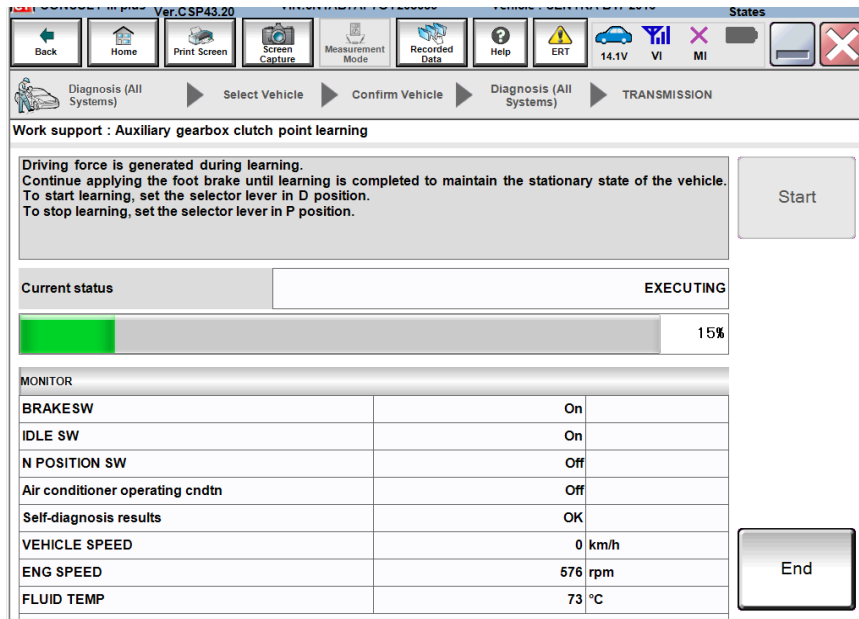

Figure 47

89. When **Completed** is displayed, select **End**.

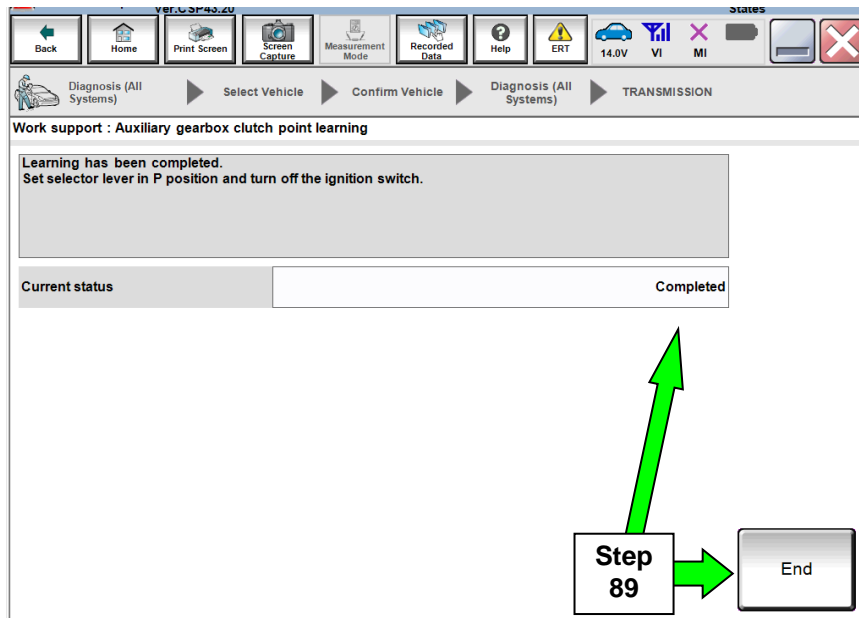

Figure 48

90. Shift the vehicle into “P”, turn ignition OFF and release the brake pedal.

91. Perform **Auxiliary Gearbox Clutch Point Learning** (steps 83 to 89) one additional time (a total of two times).

## Erase DTCs

**NOTE:** This procedure is for all Applied Vehicles.

92. Use C-III plus to erase any transmission DTCs that may have stored.

93. Turn OFF C-III plus.

94. Disconnect C-III plus and the plus VI from the vehicle.

95. Verify the CVT operates normally and no abnormal noises are heard during a test drive.

## MANUAL AUXILIARY GEARBOX CLUTCH POINT LEARNING

**CAUTION:** If clutch touch point learning is not performed, you may feel shift shock when the auxiliary transmission shifts.

**NOTE:** This manual procedure is only needed if the auto procedure is not available in C-III plus.

a. Start the engine and warm up the CVT fluid to 50°C (122°F).

**NOTE:** Confirm the CVT fluid temperature by “FLUID TEMP” in “Data Monitor”.

b. Turn the air conditioner OFF.

c. Shift the CVT selector lever to the P position, turn the ignition OFF and then wait for 5 seconds.

d. Start the engine and allow it to idle for 5 seconds.

e. Turn the ignition OFF and then wait for 30 seconds.

f. Perform Step “e” to Step “f” two more times (Total: Three times).

g. Start the engine.

h. Allow engine to idle for 30 seconds.

i. Shift the CVT selector lever to D position.

j. Accelerate the vehicle from 0 km/h (0 MPH) to 65 km/h (40 MPH) at low throttle (0.5/8 – 1/8).

k. Decelerate the vehicle to 30 km/h (18 MPH) or less without using brakes.

l. Stop the vehicle and shift the selector lever to P position.

m. Turn the ignition OFF and wait for 5 seconds or more.

n. Restart the engine.

o. Perform Step “j” to Step “o” four times (Total: Five times).

p. Shift the selector lever to D position.

q. Accelerate the vehicle from 0 km/h (0 MPH) to 45 km/h (28 MPH) at low throttle (0.5/8 – 1/8).

r. Stop the vehicle and shift the selector lever to P position.

s. Turn the ignition OFF for 5 seconds or more and then restart the engine.

t. Perform Steps “q” to Step “t” four times (Total: Five times).

u. Drive the vehicle and check that no shock occurs while shifting gears.

## PARTS INFORMATION

### All Vehicles

DESCRIPTION	PART #	QUANTITY
GASKET (CVT drain plug)	11026-JA00A	1
NS-3 CVT Fluid (All vehicles listed below <b>except</b> 2012 MY Versa Sedan)	999MP-NS300P (1)	as needed
NS-2 CVT Fluid (2012 MY Versa Sedan <b>only</b> )	999MP-NS200P (1)	as needed

(1) NS-2 and NS-3 CVT Fluids can be ordered through the Nissan Maintenance Advantage program: Phone: 877-NIS-NMA1 (877-647-6621). Website order via link on dealer portal [www.NNAnet.com](http://www.NNAnet.com) and click on the "Maintenance Advantage" link.

### Versa Sedan MY 2013-2017 and Versa NOTE MY 2014-2017

DESCRIPTION	PART #	QUANTITY
KIT-CONTROL VALVE	3170E-X428B	1
<b>Kit Includes</b>		
VALVE ASSY - CONTROL	--	1
GASKET - OIL PAN	--	1
STRAINER ASSY-OIL	--	1

### Versa Sedan MY 2012

DESCRIPTION	PART #	QUANTITY
VALVE ASSY - CONTROL	31705-3JX8A	1
STRAINER ASSY-OIL	31728-3JX0B	1
GASKET - OIL PAN	31397-3JX0A	1

### Sentra MY 2013-2017

DESCRIPTION	PART #	QUANTITY
KIT-CONTROL VALVE	3170E-X428C	1
<b>Kit Includes</b>		
VALVE ASSY - CONTROL	--	1
GASKET - OIL PAN	--	1
STRAINER ASSY-OIL	--	1

**CLAIMS INFORMATION**

**Submit a Primary Part (PP) type line claim using the following claims coding:**

<b>OPERATION</b>	<b>PFP</b>	<b>OP CODE</b>	<b>SYM</b>	<b>DIAG</b>	<b>FRT</b>
Replace Control Valve	(1)	JD48AA	HC	32	(2)

- (1) Refer to the Electronic Parts Catalog (FAST) and use the applicable Control Valve Assembly Part Number (31705-\*\*\*\*\*) as the Primary Failed Part.
- (2) Reference the current Nissan Warranty Flat Rate Manual and use the indicated flat rate time.

**And if needed on the same line**

<b>OPERATION</b>	<b>OP CODE</b>	<b>FRT</b>
Reprogram TCM	JE99AA	(1)

- (1) Reference the current Nissan Warranty Flat Rate Manual and use the indicated flat rate time.