



Mitsubishi Motors North America, Inc.

6400 Katella Avenue
Cypress, CA 90630
Telephone: 714-372-6000
www.mitsubishicars.com

Date: 1/30/2018

To: All Mitsubishi Dealers, Service Managers, and Parts Managers

Subject: High Voltage Battery Replacement / Repair

The exciting new 2018 Outlander PHEV is now available for sale! This “halo” vehicle has many unique and state-of-the-art features and equipment – including the high voltage (HV) lithium-ion battery.

In conjunction with the PHEV launch and subsequent increase in EV units in operation, MMNA has strategically and aggressively evaluated the existing i-MiEV HV battery exchange process, and has made enhancements that will enrich dealer compensation and minimize customer inconvenience. Effective February 1, 2018, MMNA will convert the existing HV battery exchange program to a new battery replacement and repair program – for both Outlander PHEV and i-MiEV.

The current \$500 + labor reimbursement for i-MiEV HV battery exchange and replacement has been increased to \$1,500 parts mark-up + labor cost – for both Outlander PHEV and i-MiEV. The \$1,500 parts mark-up will be added to the dealer net price of the new battery automatically by MMNA during warranty claim processing.

In an effort to keep dealer costs low and to minimize the inconvenience of battery handling, storage, and disposition, MMNA will continue to absorb the burdensome costs associated with:

- Procuring the high cost equipment (battery lifting table and portable pallet stacker) for HV battery removal and reinstallation – necessary for battery replacement or repair
- Transportation expense of shipping this equipment from MMNA to the dealer and back to MMNA
- HV battery inventory cost and special storage procedures
- Expedited shipping of replacement HV battery to dealers
- Return shipping of defective HV battery from dealers
- Storage and proper recycling costs of defective HV battery

As a result of the special requirements related to HV battery replacement and repair, MMNA strongly believes this new process achieves a fair rate of return for dealers while providing the mechanism for minimizing any customer inconvenience, and continued customer satisfaction with your dealership and the Mitsubishi brand.

Please ensure your technicians have taken the EV Technical Training courses to make sure they are familiar with the risks, proper HV battery diagnosis and repair/replacement options, and unique service requirements of EV vehicles.

Please see Warranty Bulletin WB 2018-005 for additional details and **refer to the enclosed process flow chart for an overview of the HV battery distribution and handling process.**

If you have any questions, please contact your District Parts and Service Manager.

Sincerely,

MMNA Fixed Operations

Dealer HV Battery Repair/Replacement Process

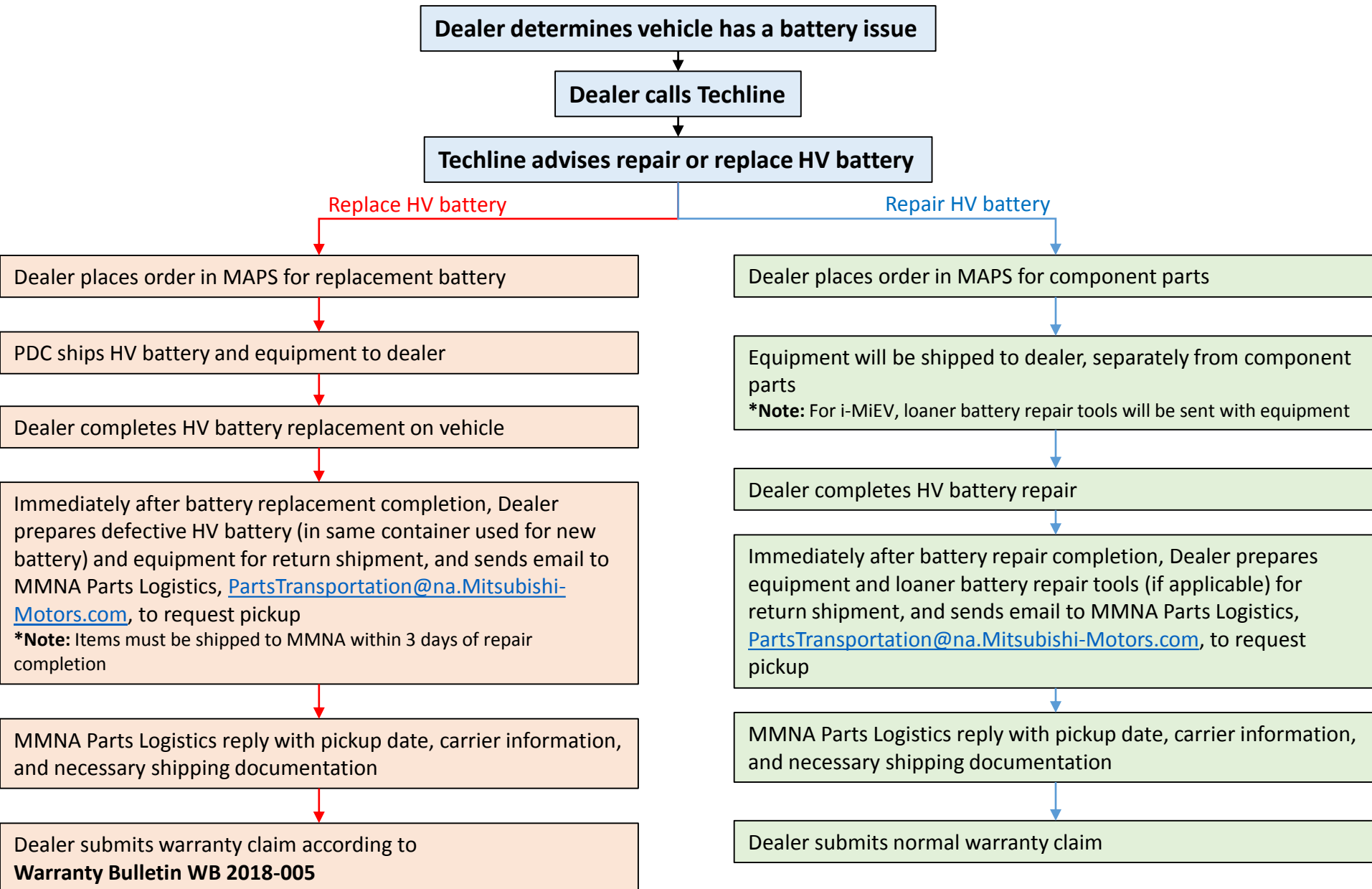



WARRANTY BULLETIN

Replaced Outlander PHEV & IMiEV Main Drive Batteries will now include a \$1,500 Warranty Parts Markup

Warranty Bulletin Application		
USA	Canada	P. Rico
X		X
Issue Date		February 1, 2018
Bulletin Number		WB 2018-005

Effective with orders placed on or after February 1, 2018, sourcing of an Outlander PHEV or IMiEV main drive battery warranty replacement will no longer utilize an exchange process where the dealer is automatically sent an exchange battery at no charge.

After the MMNA Techline has authorized a dealer to replace an Outlander PHEV or IMiEV main battery, the dealer will place the main battery order themselves from their PDC. The PDC will charge the dealer the net price and ship the battery along with the loaned lift tools. When the repair is completed, the dealer notifies the MMNA Parts Inventory Department to advise them so that they can schedule a pickup of the replaced battery and the loaned tools. The dealer then enters their related warranty claim for the recovery of the dealer net parts price and labor charges. During claim processing, MMNA will suspend the claim and apply a set \$1,500 as the warranty parts markup. Be sure you enter the correct part number for actual battery used in the repair.

The \$1,500 markup will take into account MMNA's absorbing the costs of the expedited back and forth battery shipping and the loan of the needed main battery lift tools. MMNA will also cover the costs of a proper documented disposal of the replaced main battery.

MMNA Techline must still be contacted when there is a potential need to replace a main drive battery. They will provide help with diagnosis and if appropriate, authorization. Also, refer to related dealer letter for additional information ([click here](#)).

Outlander PHEV Main Drive Lithium Battery

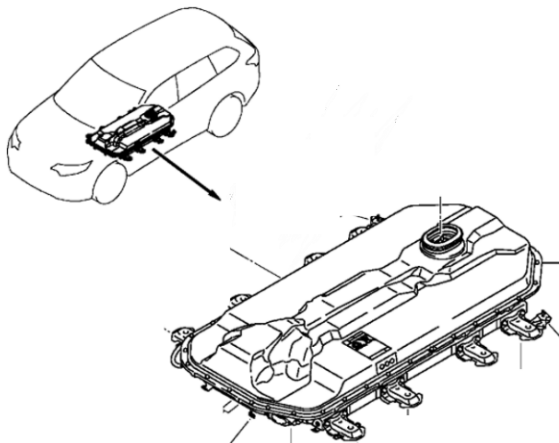

I-MiEV Main Drive Lithium Battery

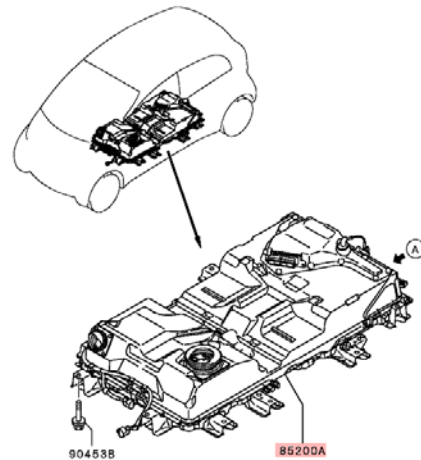

If you have any questions, please call the Warranty Information Line @ 1.800.380.2324. You may also email us at WarrantyWebHotline@mmsa.com

MMNA WARRANTY ADMINISTRATION

Check Box As Reviewed:	<input type="checkbox"/>	Service Manager	<input type="checkbox"/>	Office Manager	<input type="checkbox"/>	Warranty Administrator
	<input type="checkbox"/>	Parts Manager	<input type="checkbox"/>	General Manager	<input type="checkbox"/>	Other