



Service Bulletin No. 459

| | | | |
|---|--|---|---|
| <small>MODEL</small> D Series | <small>TYPE</small> Field Change Program | <small>SECTION/GROUP</small> 8-Engine | <small>DATE</small> Jan. 26, 2018 |
| <small>SUBJECT</small> TAILPIPE AND BUMPER SHIELD | | | |
| <small>CONDITIONS</small> | | | |

Customer Complaint:

Motor Coach Industries ("MCI") has become aware that the potential may exist for heat damage to occur to the rear bumper assembly on coaches equipped with an ISX G engine.

Cause:

Failure to adhere to the two foot required space between the rear bumper and an exhaust obstacle behind the coach.

Corrective Action:

MCI strongly urges owners of the coaches equipped with an ISX G engine in the unit range listed below to have the retrofit performed as soon as possible.

| | | | | |
|----------------|--|--|--|--|
| 13751 to 14785 | | | | |
|----------------|--|--|--|--|

Parts

| Qty. | New P/N | Description |
|-------------|----------------|--|
| 1 | 26-08-0034 | Kit, Tailpipe and Bumper Shield, ISL G <i>Kit Contents are:</i> |
| 1 | 03-21-1733 | Shield Assy., Bumper |
| 1 | 08-20-1561 | Clamp |
| 1 | 08-20-2728 | Tailpipe Assy., ISL CNG |
| 3 | 19-01-1529 | Capscrew |
| 3 | 19-05-0388 | Spacer |
| 1 | 26-08-0049 | Kit, Tailpipe Support <i>Kit Contents are:</i> |
| 1 | 08-01-1043 | Bracket |
| 1 | 19-01-1570 | Capscrew, Flanged, 3/8 |
| 1 | 19-03-0535 | Locknut, Flanged, 3/8 |

⚠ WARNING

As detailed in the MCI Maintenance Manuals in addition to the decal on the roadside rear bumper, do not park the coach with the rear bumper within two feet of a barrier or obstruction.



Figure 1. Hot exhaust warning decal.

Service Procedure:

⚠ WARNING

Read this entire procedure before beginning work.

Use Safe Shop Practices At All Times.

To avoid personal injury, never enter or perform work in the engine compartment prior to positioning the ENGINE RUN and ENGINE START switches on the engine compartment remote control box to the OFF position. Allow enough time for components to cool down prior to working in the engine compartment.

1. Turn the main battery disconnect to the OFF position.
2. Chock both sides of the tires.

⚠ WARNING

Allow enough time for the tailpipe assembly to cool down prior to performing retrofit steps.

3. Locate the existing tailpipe on the roadside section of the rear bumper.

4. Remove and discard the existing tailpipe and mounting clamp.
5. Orient the shield assembly, p/n 03-21-1733, as shown in Figure 2 to identify the existing bumper bolts to be removed.

NOTICE

The spacers are utilized to create a gap between the bumper and the shield assembly.

6. Remove and discard the three (3) identified bolts from the bottom of the bumper, required to mount the shield assembly. Orient the capscrews, p/n 19-01-1529, through the shield holes and position the spacers, p/n 19-05-0388, on top of the shield assembly and underneath the bumper. Align and mount assembly to the bumper using the existing nuts and clipnuts as shown in Figure 2. Torque capscrews to 45-50 ft-lbs.
7. Orient the new clamp, p/n 08-20-1561, and tailpipe, p/n 08-20-2728, to the exhaust outlet. Torque to 38-45 ft-lbs.

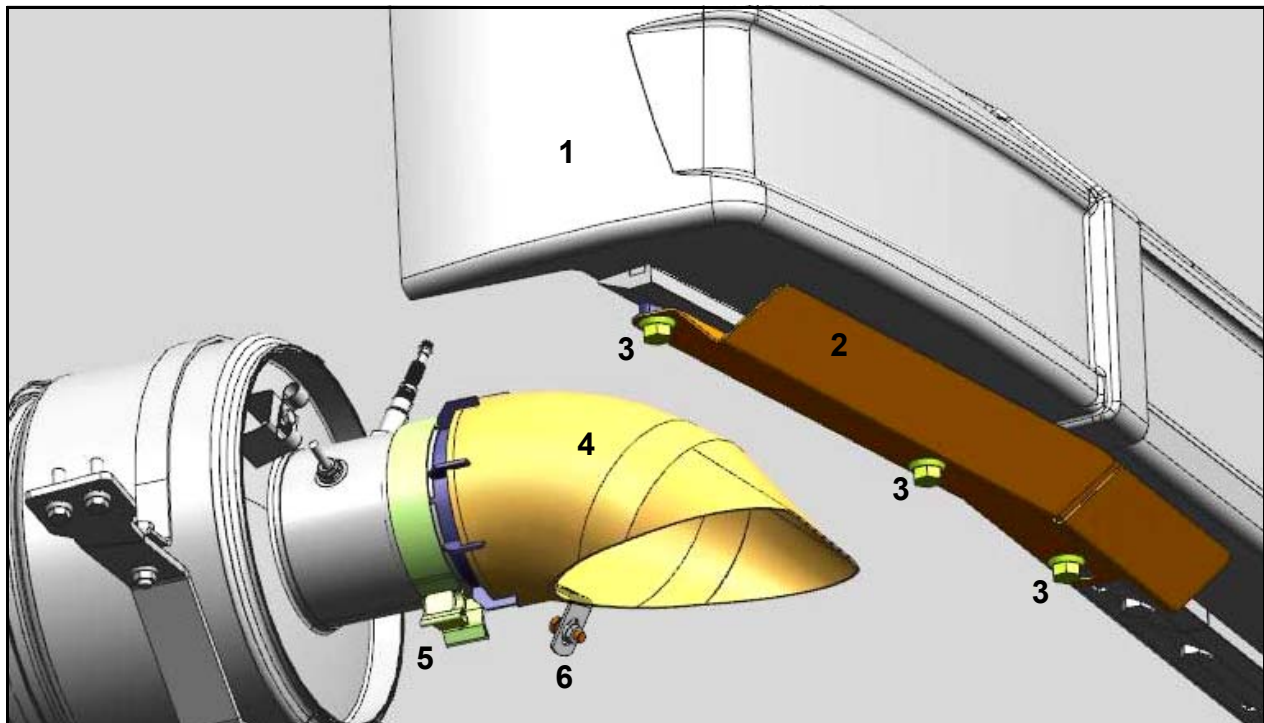

Figure 2.

| Item | Figure 2 Description |
|------|--------------------------------------|
| 1 | rear bumper, roadside section |
| 2 | shield assembly |
| 3 | shield assembly capscrews, qty. of 3 |
| 4 | tailpipe |
| 5 | clamp |
| 6 | tailpipe support bracket |

8. Orient and position the short flange of the bracket, p/n 08-01-1043, inside the tailpipe as shown in Figures 2 and 3. Using the hole in the bracket as a drilling template, mark the location of the hole with a scribe or marker.
9. Using a 0.438 drill bit, drill a hole. Secure the installation with the capscrew and locknut. Torque the locknut to 40-44 ft-lbs.

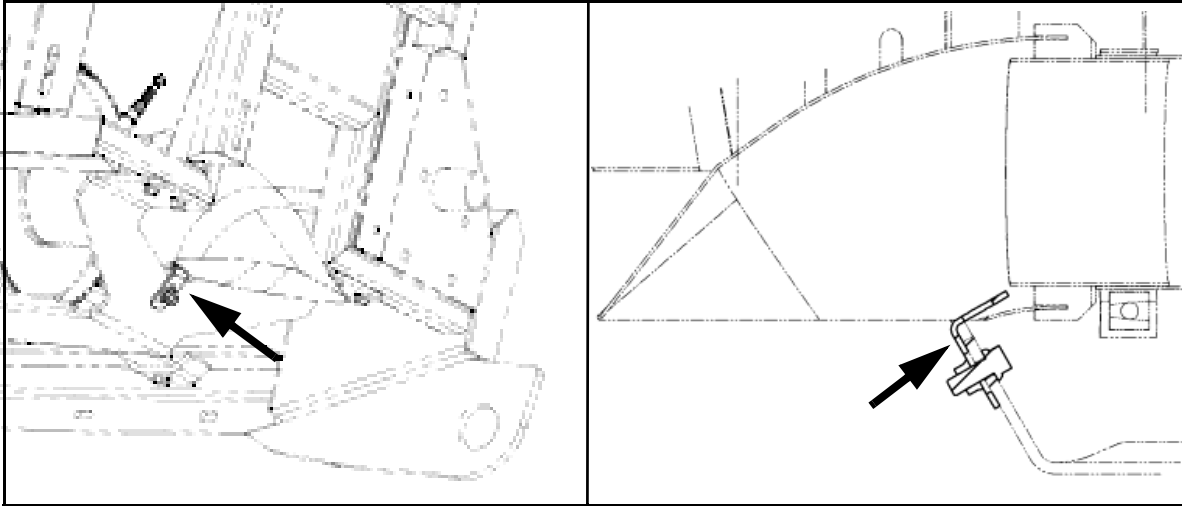

Figure 3. Tailpipe support bracket positioning.

Procedure Complete.



Mail or fax the completed limited warranty claim form and verification form to MCI's warranty department, or photocopy and mail to:

MCI Fleet Support
Attn: Warranty Department
7001 Universal Coach Drive
Louisville, KY 40258
Fax Number 1-800-360-8886

to receive credit for the hours used to complete this task. Contact the MCI Fleet Support Technical Center at 1-800-241-2947 for any further information.

Field Change Program Conditions:

The parts required for this change will be supplied without charge.

A labor allowance of 0.5 hour will be granted for this rework on affected D series coaches.

This labor allowance will be credited to your MCI Fleet Support Parts Account on receipt of the attached "MCI Field Change Program Verification Form" and a "Warranty Claim Form" as detailed in your Owner Warranty manual to MCI's Warranty department. A "MCI Field Change Program Verification Form" needs to be submitted for each VIN affected. Photocopy the attached "MCI Field Change Program Verification Form" as required for the number of affected coaches in your fleet.

This program will end on August 9, 2018.

Motor Coach apologizes for any inconvenience resulting from this campaign, but urges you to implement this change as soon as possible.

Sincerely,

Motor Coach Industries



Reliability Driven™

MCI FIELD CHANGE PROGRAM (FCP) VERIFICATION

| | |
|--|--|
| CONTACT INFORMATION | |
| CUSTOMER NAME: _____ | |
| <small>(PLEASE PRINT)</small> | |
| FCP INFORMATION – ONE FORM PER UNIT | |
| FCP#: _____ | Coach Model _____ Model Year _____ |
| COACH SERIAL #: <small>(At least the last 5 digits)</small> | DATE COMPLETED __ / __ / __ |
| MILEAGE: | |
| <u>IMPORTANT:</u> TO RECEIVE CREDIT FOR ANY ALLOWABLE LABOR CHARGES, THIS VERIFICATION FORM MUST BE RETURNED TO MCI UPON COMPLETION OF THE FCP. | |
| SUBMITTED BY: (Please Print) _____ | |
| | DATE __ / __ / __ |
| TITLE: (Please Print) _____ | |
| SIGNATURE: _____ | |
| COMMENTS: | |

FAX TO: 800-360-8886

MAILING ADDRESS:

**MOTOR COACH INDUSTRIES
ATTN: WARRANTY DEPT.
7001 UNIVERSAL COACH DRIVE
LOUISVILLE, KY 40258**