

THIS LSC EXPIRES DECEMBER 31, 2017

**TECHNICAL INSTRUCTIONS
FOR
LIMITED SERVICE CAMPAIGN
F0B
OCCUPANT CLASSIFICATION SYSTEM (OCS) SENSOR
CERTAIN
2012 – 2013 MODEL YEAR YARIS HATCHBACK**

All dealership associates involved in the campaign process are required to successfully complete E-Learning course SC13A. To ensure that all vehicles have the repair performed correctly; technicians performing this recall repair are required to currently hold at least one of the following certifications levels:

- Toyota Expert (Electrical)
- Master
- Master Diagnostic Technicians

I. OPERATION FLOW CHART

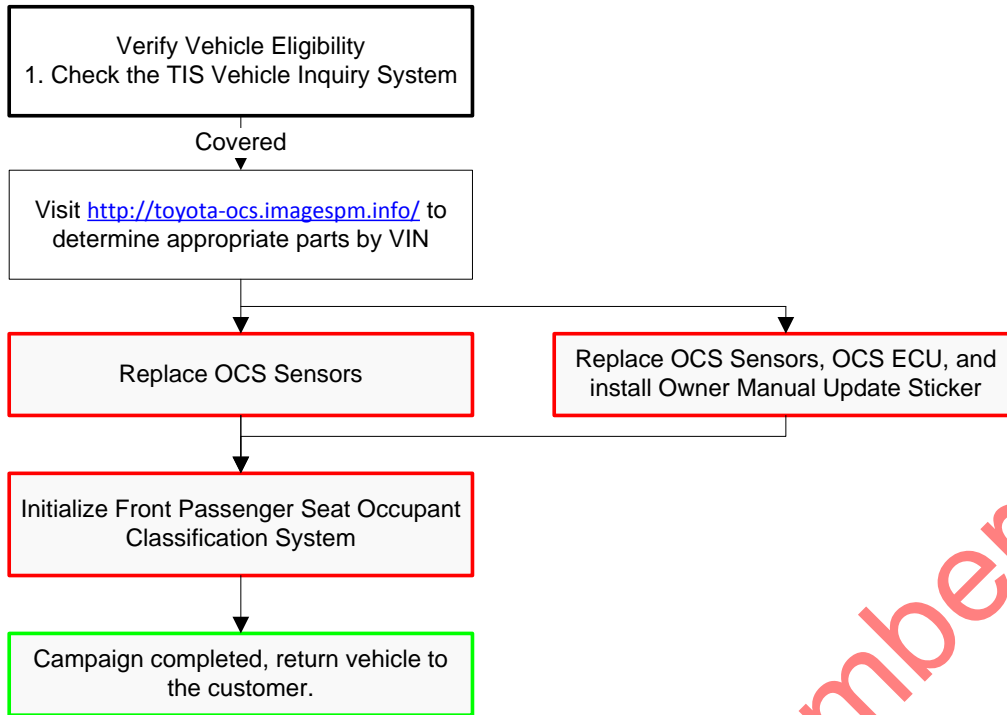

II. IDENTIFICATION OF AFFECTED VEHICLES

NOTE:

- Check the TIS Vehicle Inquiry System to confirm the VIN is involved in this Safety Recall, and that the campaign has not already been completed prior to dealer shipment or by another dealer.
- **TMS warranty will not reimburse dealers for repairs conducted on vehicles that are not affected or were completed by another dealer.**

III. PREPARATION

A. PARTS

| Part Number | Part Description | Quantity |
|--|---|----------|
| 04004-71147 | SENSOR KIT, WEIGHT DETECTOR* | 1 |
| *The kit above includes the following parts. | | |
| 89105-47030 | SENSOR SUB-ASSY, WEIGHT DETECTOR FR INN | 1 |
| 89106-47030 | SENSOR SUB-ASSY, WEIGHT DETECTOR FR OUT | 1 |

| Part Number | Part Description | Quantity |
|--------------|-------------------------------|----------|
| 04004-61152* | COMPUTER, OCCUPANT DETECTION* | 1 |

*The OSC ECU will only be replaced on small number of vehicles. Refer to the website below to determine if the OCS ECU needs to be replaced:
<http://toyota-ocs.imagespm.info/>
Default Password: xxxxx

B. TOOLS & EQUIPMENT

- Standard Hand Tools
- Techstream
- Torque Wrench

SST- These are essential special service tools that the dealership should have.

| Part Number | Description | Quantity |
|----------------|-----------------------|----------|
| 00002-06000-01 | Plastic Pry Tool Set | 1 |
| 00002-09077-01 | OCCUPANT SEAT WEIGHTS | 1 |

C. OWNER'S MANUAL UPDATE

The owner's manual will need to be updated when the OCS ECU is replaced. The stickers for the owner's manual can be ordered from the MDC for the continental US and Alaska.

| MDC Number | Description | Quantity |
|--------------|------------------------|----------|
| 00411-140007 | Owner's Manual Sticker | 1 |

IV. WORK PROCEDURE TABLE OF CONTENTS

| | |
|---|---------------|
| COMPONENTS | SECTION VII. |
| REPLACE THE OCCUPANT CLASSIFICATION SYSTEM SENSOR | SECTION VIII. |
| APPENDIX..... | SECTION IX. |

V. BACKGROUND

The front passenger seat assembly is equipped with sensors for the occupant classification system which are used to control the operation of supplemental restraint systems (SRS), including the front passenger airbag. The sensors classify the weight of the occupant and activate or deactivate the front passenger airbag accordingly. Additionally, the sensors are used to detect certain vehicle collisions. Due to the current collision detection thresholds, the system may interpret certain occupant seating usages or road conditions as a rear collision and illuminate the Airbag Warning Light and "AIR BAG OFF" indicator, disabling the front passenger air bag.

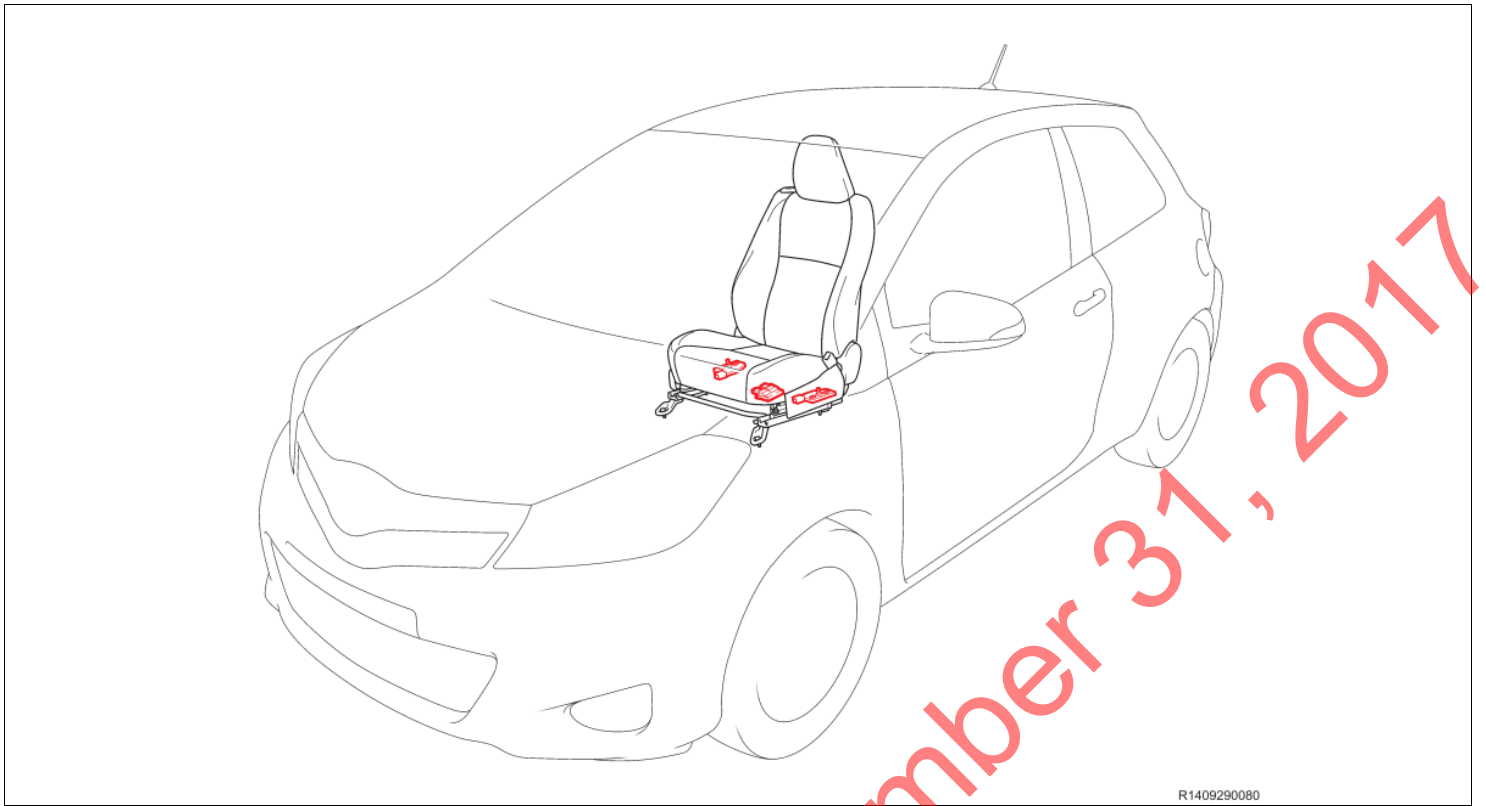

VI. COMPONENTS

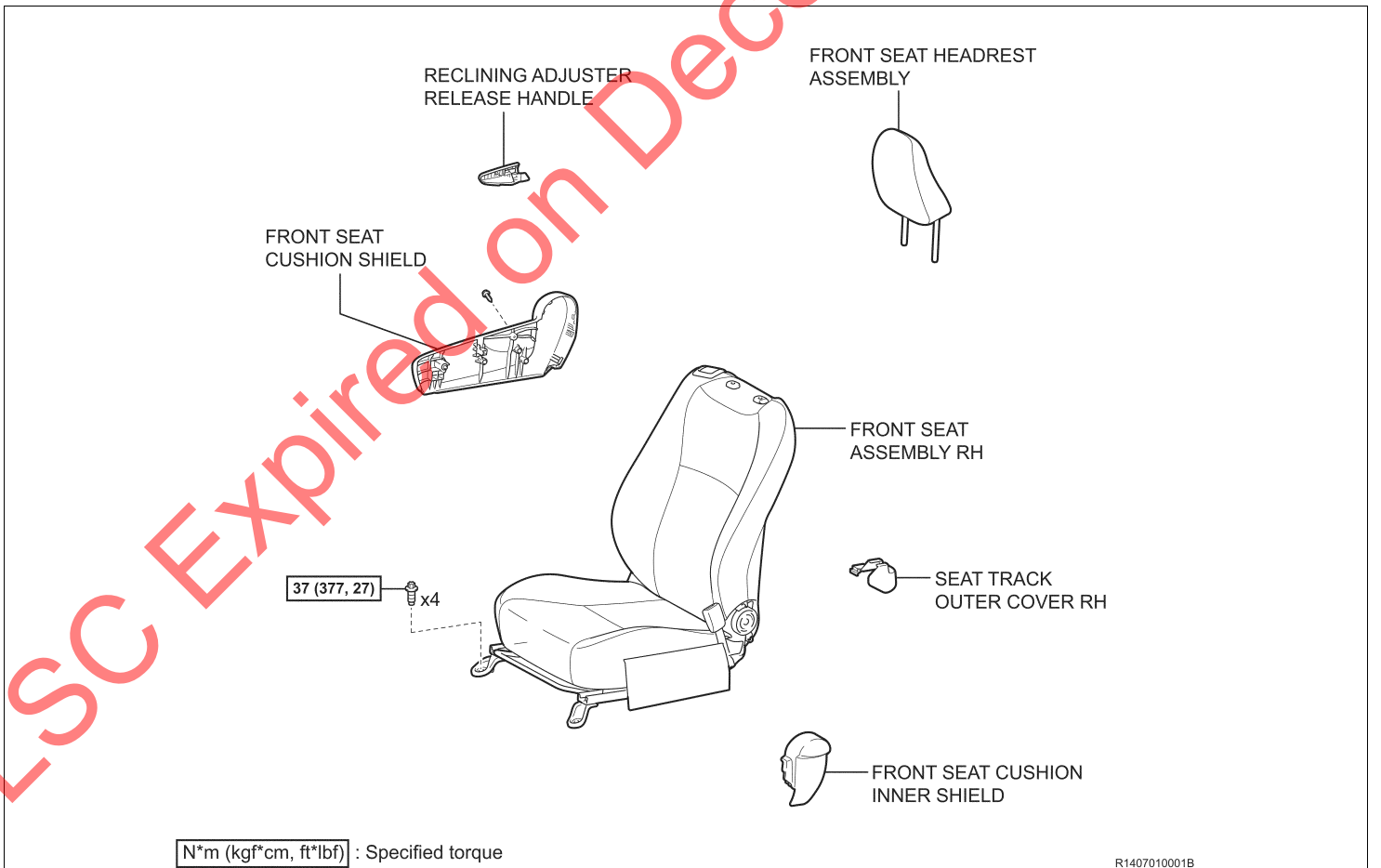

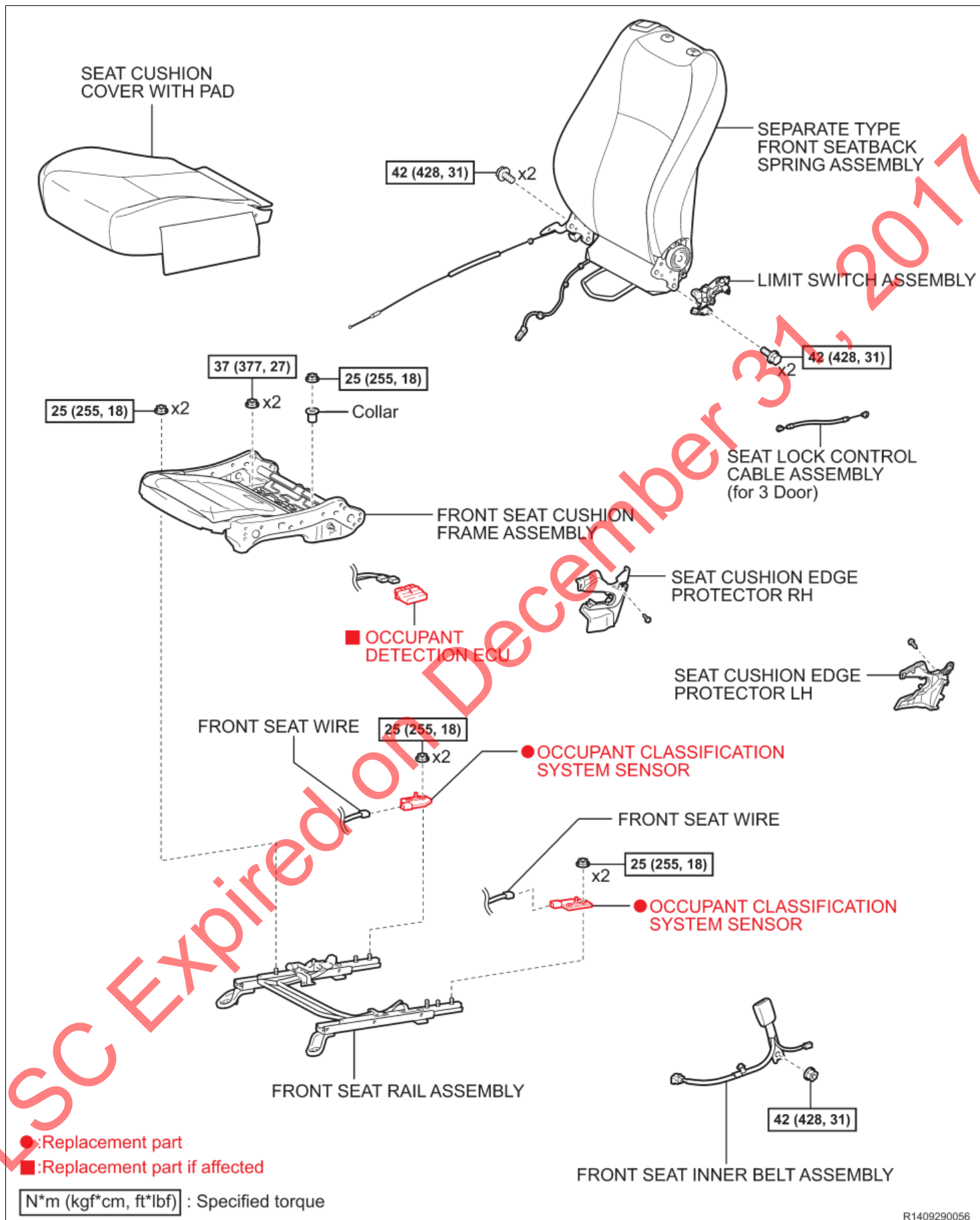

R1409290056

VII. REPLACE THE OCS SENSORS

1. CHECK FOR DTCs



This campaign only covers the replacement of the OCS sensors and on a small number of vehicles the OCS ECU.
No other components in the SRS system are covered by this campaign.

- a) Using Techstream, perform a health check to confirm if there are any SRS system related DTCs present in the system (**current, history or pending**).

NOTES:

- Ensure that the Techstream software is 9.2 or higher.
- On the “connect to vehicle” screen, enter the VIN number to ensure that the vehicle information is uploaded to TIS.
- Record any SRS system DTCs to aid in any additional discussions needed with the customer.

2. RECORD SYSTEM SETTINGS

- a) Record any audio and climate control settings prior to disconnecting the negative battery terminal.

3. INSPECT THE OPERATION OF THE RIGHT FRONT SEAT SLIDING & RECLINING FUNCTIONS

- a) Slide the right front seat fully forward.
b) Slide the seat back slowly ensuring that the seat fully locks into each position.
c) Check that the backrest operates smoothly and fully locks in each position.



- In case of locking failure, replace the lower seat frame.
- Confirm the proper seat operation to compare with step 34.

4. RECORD THE POSITION OF THE RIGHT FRONT SEAT

5. DISCONNECT CABLE FROM NEGATIVE BATTERY TERMINAL

- a) Always disconnect the negative terminal before working with any SRS components in order to prevent unintentional deployment.
b) Wait 90 seconds or more after disconnecting the negative terminal before performing any work due to the backup power supply equipped to the airbag system.

6. INSTALL PROTECTIVE COVERS

- a) Apply protective covers to the following areas to prevent interior parts and the vehicle body from being damaged during R&R of the right front seat.

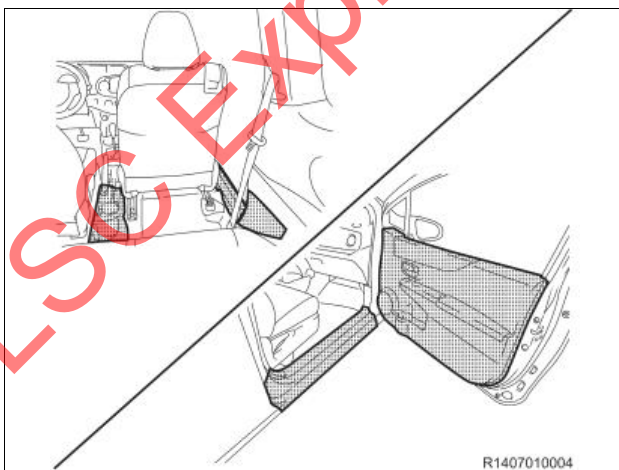

7. REMOVE THE RIGHT FRONT SEAT



- When replacing the OCS sensor, it is necessary to mark the position of certain parts prior to removal in order to assure proper alignment during reassembly.
- **DO NOT** operate any lever during seat transportation.
- **DO NOT** damage interior components during R&R of the right front seat.
- 2 may be required when removing the front seat from the vehicle.

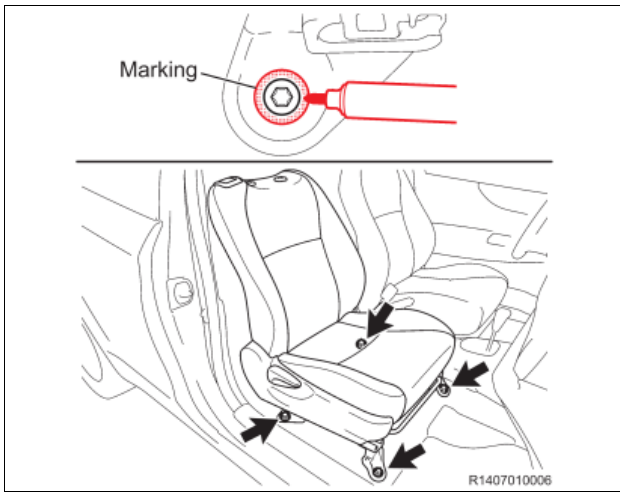

- a) Remove the headrest.
- b) Remove any seat track covers (if equipped).
- c) Mark the 4 seat mounting bolts as shown.
- d) Remove the 4 seat mounting bolts.

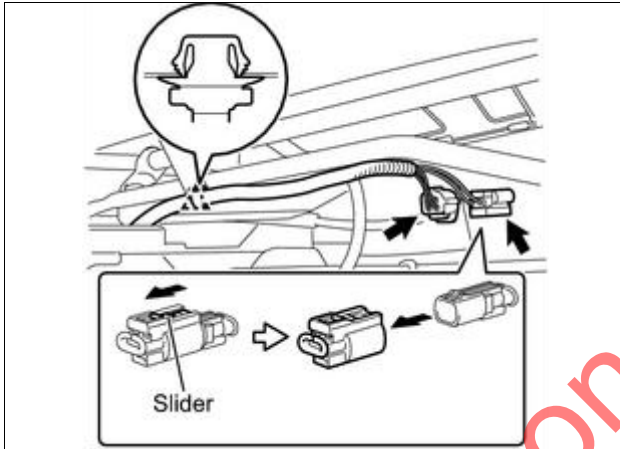

VEHICLES WITH SEAT AIRBAGS ONLY

1. Remove the harness clamp.
2. Disconnect the SRS connectors.
3. Disconnect the OCS ECU connector.

VEHICLES WITHOUT SEAT AIRBAGS

1. Disconnect the OCS ECU connector.

- e) Remove the seat, and place it on a clean workbench.

8. REMOVE THE CUSHION INNER SHIELD



Follow the procedure described to prevent damage to the cushion inner shield.

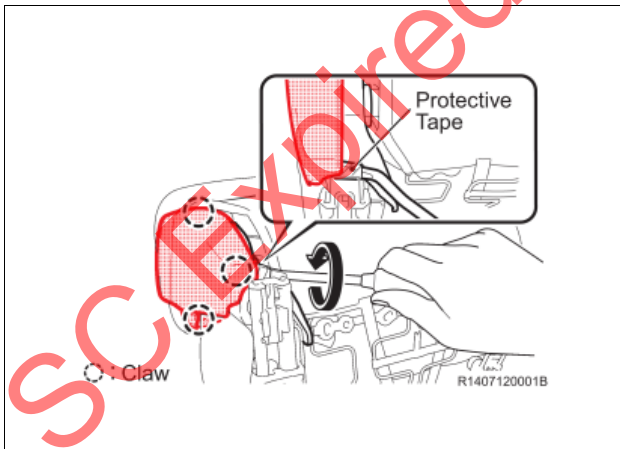

- a) Wrap the tip of the clip removal tool with tape.
- b) Position the clip removal tool as shown, and twist it to disengage the claw.
- c) Disengage the 2 remaining claws by hand.

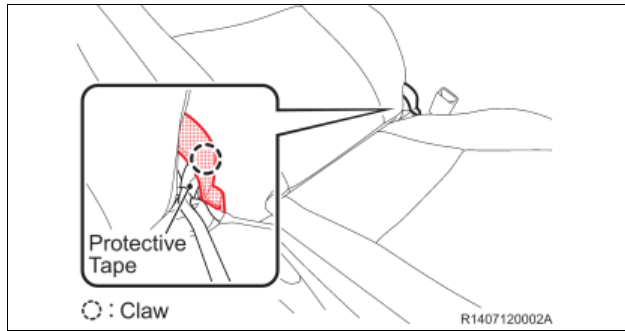

- d) Insert a clip removal tool at the position shown, and disengage the claw and remove the cushion inner shield.

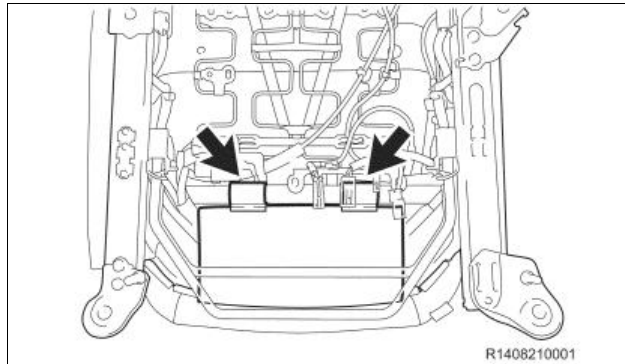

9. REMOVE THE SEAT BELT BUCKLE

- a) Disengage the 2 hooks and pull the cover back.

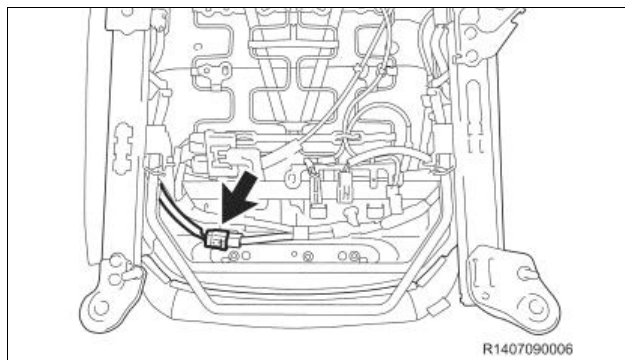

- b) Disconnect the connector.

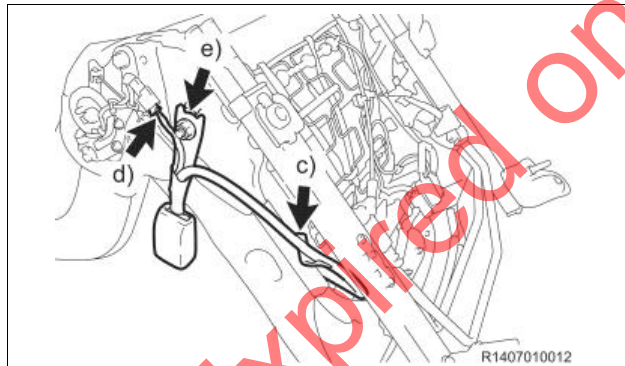

- c) Disengage the clamp.
- d) Disconnect the connector.
- e) Remove the nut and the seat belt buckle.

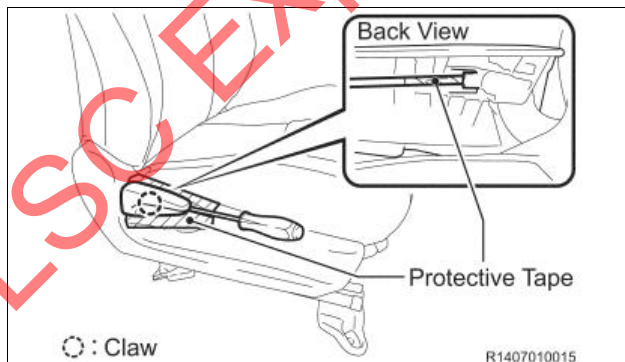

10. REMOVE THE RECLINE RELEASE HANDLE

- a) Apply protective tape to the cushion as shown.
- b) Wrap the tip of a screwdriver with tape.
- c) Raise the lever, disengage the claw.
- d) Remove the recliner release handle.

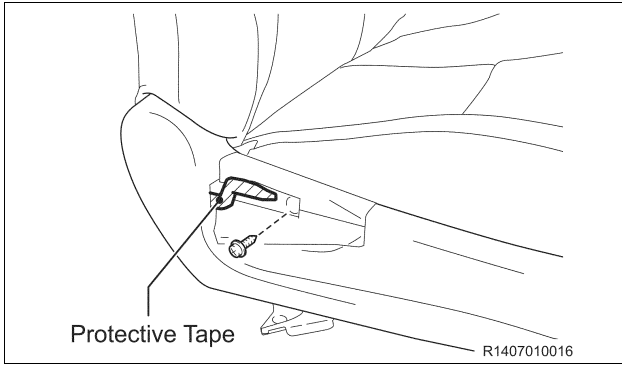

11. REMOVE THE CUSHION SHIELD

- a) Apply tape to the lever as shown.
- b) Remove the screw.

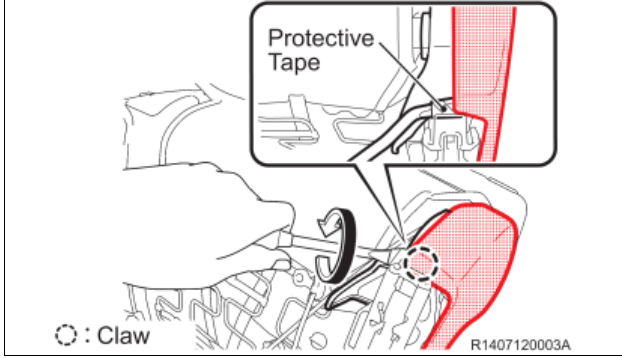

STOP Follow the procedure described below to prevent damage to the cushion shield.

- c) Wrap the tip of the clip removal tool with tape.
- d) Position the clip removal tool as shown, and twist it to disengage the claw.
- e) Insert the clip removal tool as shown in the illustration, and disengage the claw.

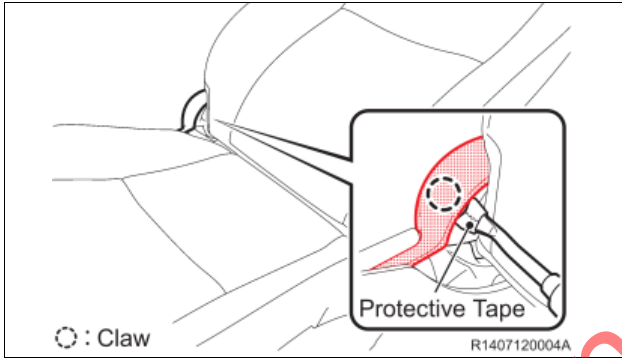

- f) Disengage the claw.
- g) Slide the shield forward to remove it.
- h) Remove the clip and reinstall it on the shield.

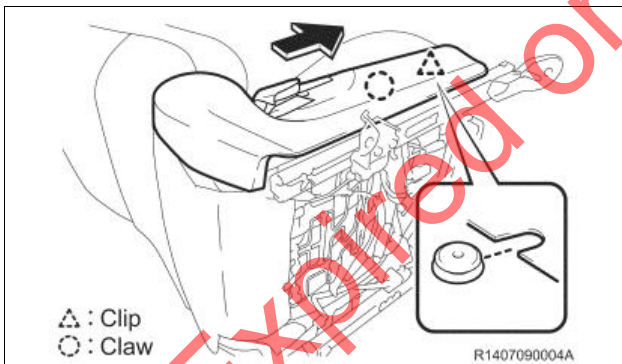

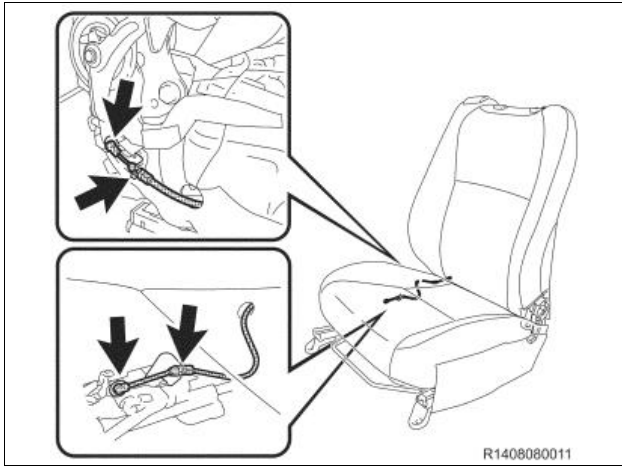

12. REMOVE THE SEAT LOCK CONTROL CABLE
3 DOOR VEHICLES ONLY

1. Disengage the 2 clamps and the 2 cable ends to remove the seat lock control cable.

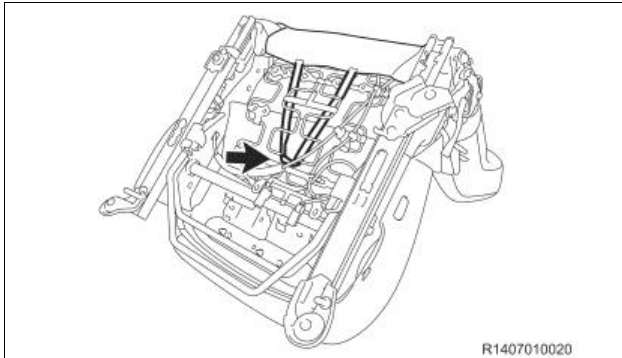

13. REMOVE THE SEATBACK

- a) Disengage the seatback cover band.

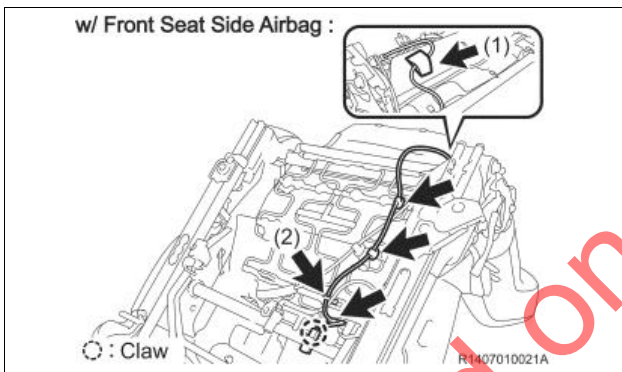

VEHICLES WITH SEAT AIRBAGS ONLY

1. Disengage the hook and loop fastener.
2. Disengage the hook.
3. Wrap the tip of a screwdriver with tape.
4. Disengage the claw at the backside of the connector.
5. Disengage the 3 clamps.

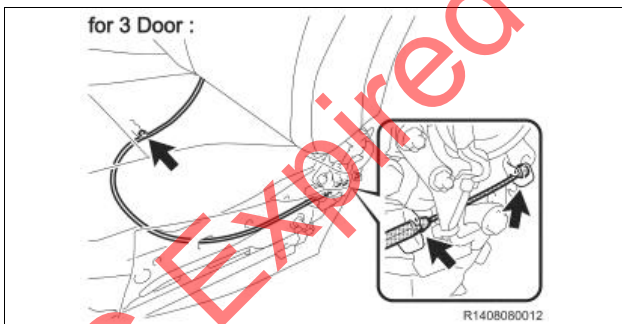

3 DOOR VEHICLES ONLY

1. Disengage the 2 clamps and the cable end.
2. Separate the seatback control cable assembly.

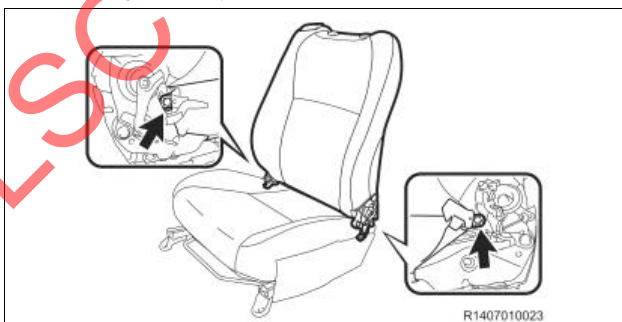

- b) Disengage the 2 plastic rings from around the bolts.

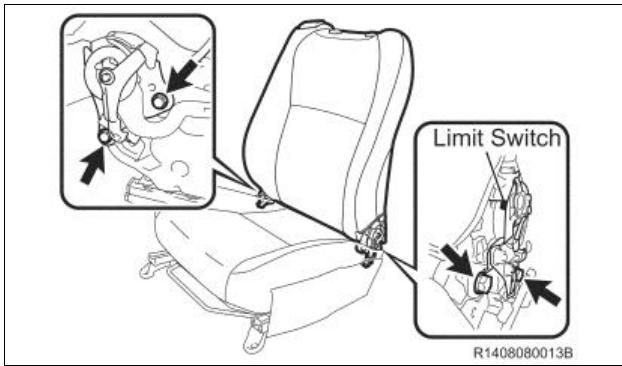

- c) Remove the 2 bolts and the limit switch from the left side.
- d) Remove the 2 bolts from the right side while holding the seatback.

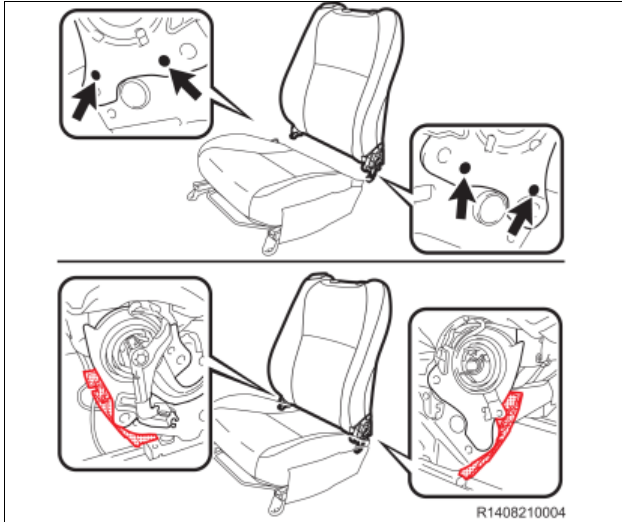

- e) Disengage the 4 pins while holding the seatback.
- f) Remove the seatback from the lower seat frame.

STOP Take care not to allow the seatback to interfere with the seat cushion edge protector.

14. REMOVE THE SEAT CUSHION AND COVER

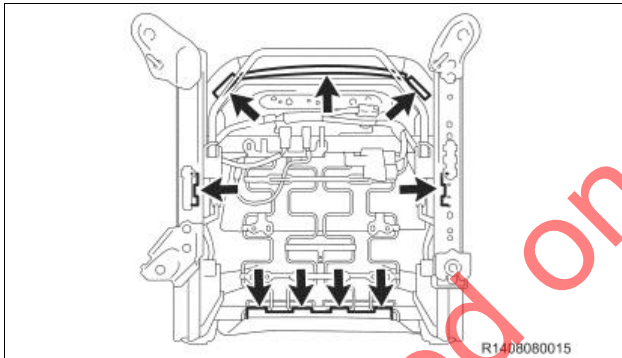

- a) Disengage the 9 hooks.

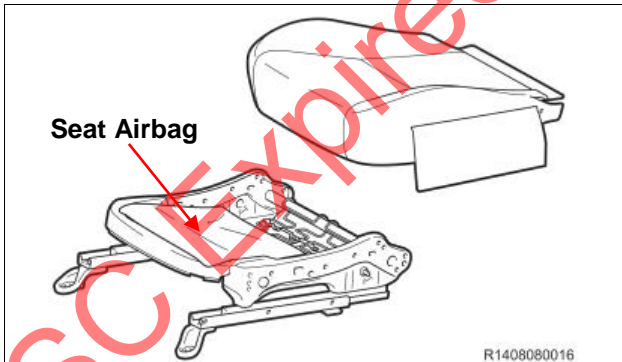

- b) Remove the seat cushion and cover.

NOTE: Be careful not to damage the seat airbag (if equipped).

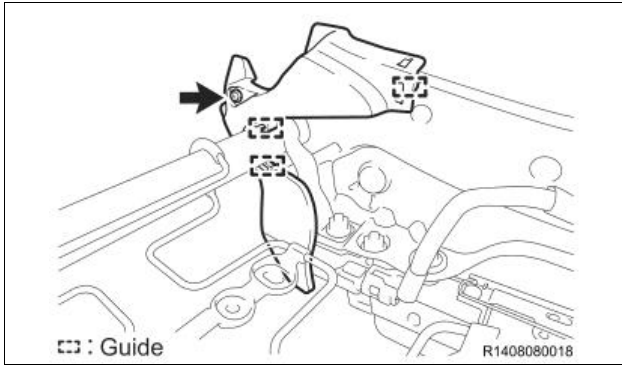

15. REMOVE THE LEFT & RIGHT SEAT CUSHION EDGE PROTECTOR

- a) Remove the screw.
- b) Disengage the 3 guides and remove the seat cushion edge protector.
- c) Repeat on other side.

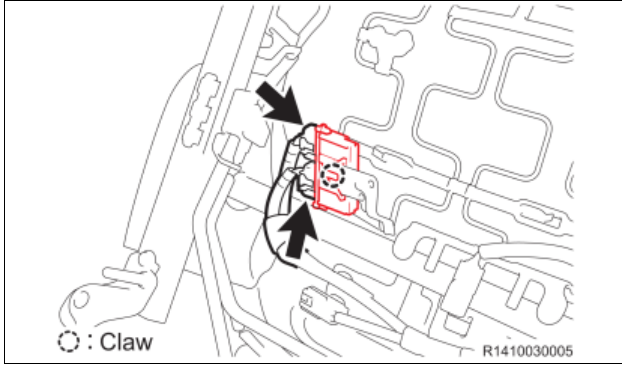

16. REMOVE THE OCS ECU

- a) Wrap the tip of a screwdriver with tape.
- b) Disconnect the 2 connectors.
- c) Disengage the claw and remove the OCS ECU.

STOP If the OCS ECU is being replaced, mark the old ECU so it is not reused.

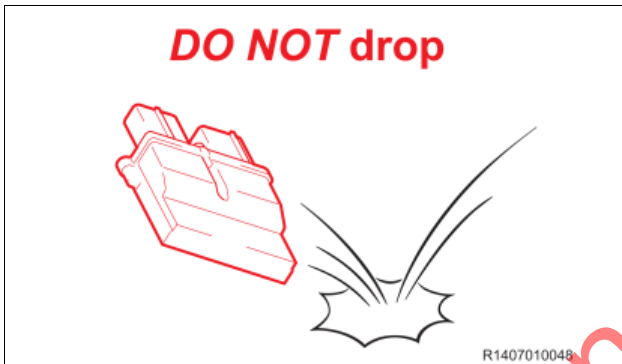

STOP DO NOT drop the ECU. If dropped replace the ECU with a NEW one and mark the dropped ECU so it is not reused.

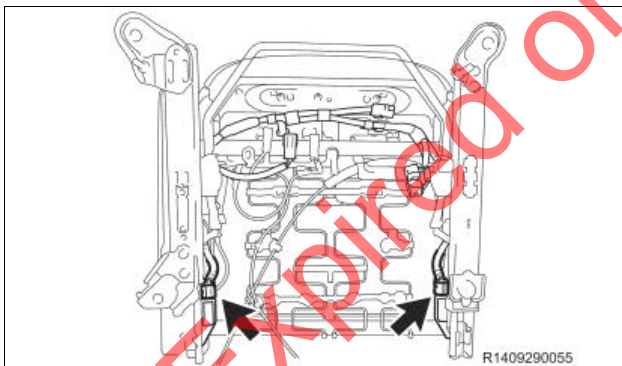

17. DISCONNECT THE OCS SENSORS

- a) Disconnect the 2 connectors.

LSC Expired on December 31, 2017

18. DISASSEMBLE THE LOWER SEAT FRAME



- Disassemble the lower seat frame with it installed in the vehicle to keep various components properly aligned.
- Disassembling and reassembling the lower seat frame outside the vehicle will cause various misalignment issues, if this occurs, replace the lower seat frame.

OK Install in vehicle before disassembly.

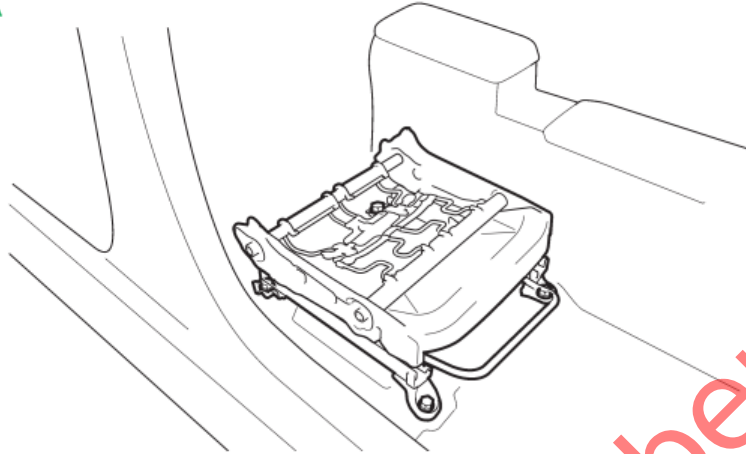

NG Disassembly without installing in vehicle.

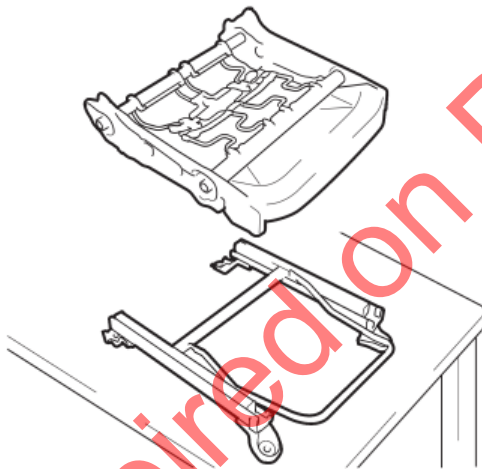

NG Loosening during disassembly.

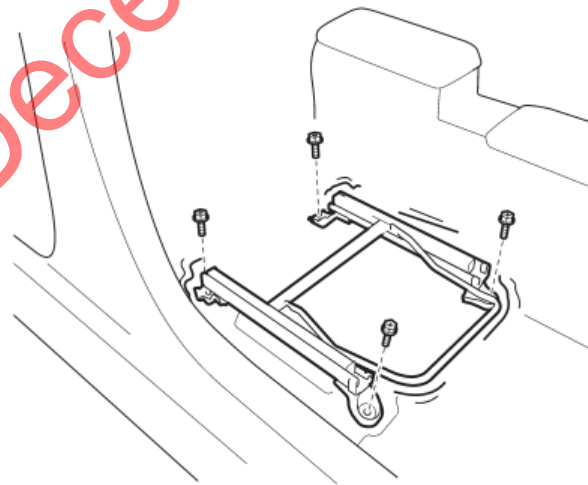

R1409260049

a) Mark the 2 nuts as shown on the lower seat frame.

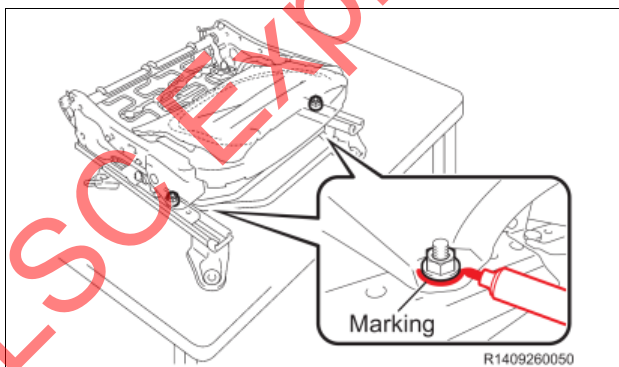

R1409260050



Be sure to mark the nuts as shown to prevent misalignment of the seat. (The marks are needed to return parts to their original position.)
It is not necessary to put marks for all 5 nuts that attach the seat frame. Marking the 2 front nuts is sufficient.



b) Temporarily reinstall the lower seat frame back into the vehicle.

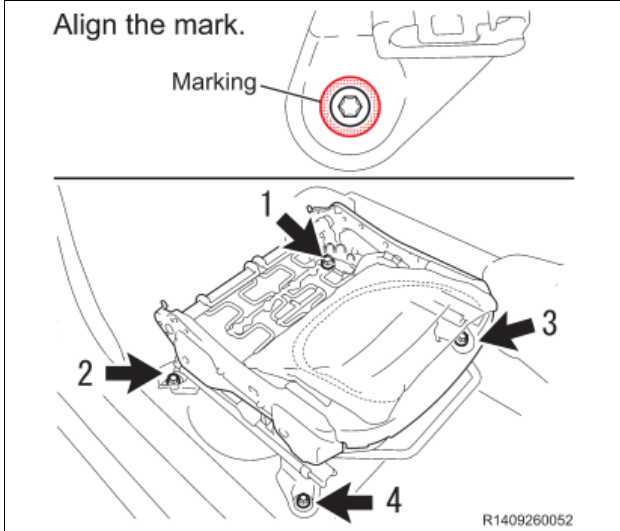

c) Temporarily reinstall the 4 seat mounting bolts so that the bolts align with the markings on the seat frame.



- Take care not to damage the body.
- Tighten evenly.
- DO NOT damage the seat airbag. (if equipped)

d) Fully tighten the bolts in the order shown in the illustration.
Torque: 37 N*m (377 kgf*cm, 27 ft.*lbf)

e) Confirm the markings are in the correct position.

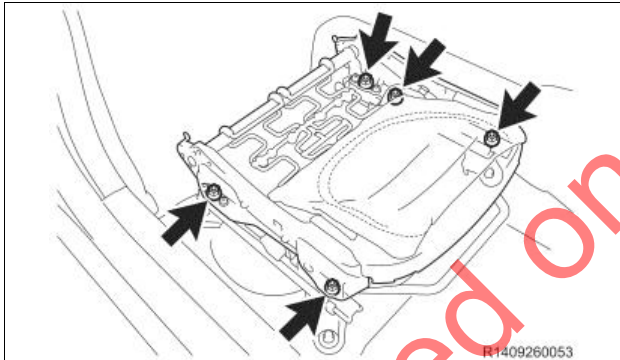

f) Remove the 5 nuts shown from the seat frame.

g) Remove the seat pan.

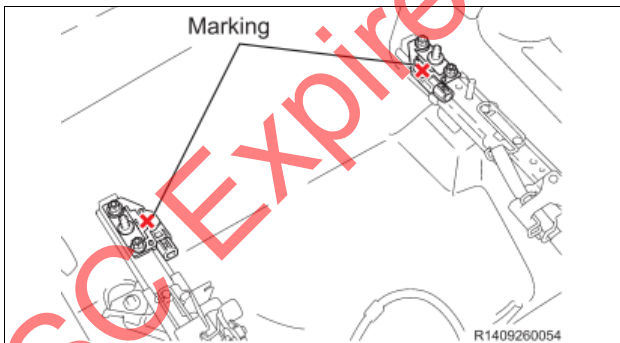

g) Mark the old left and right OCS sensors so they are not confused with the **NEW** ones.

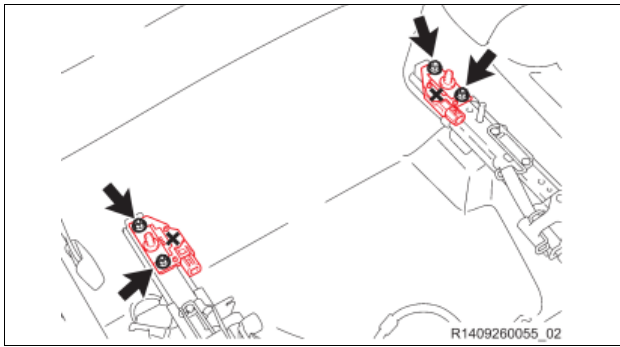

h) Remove the 2 nuts for each of the OCS sensors.

i) Remove the OCS sensors.

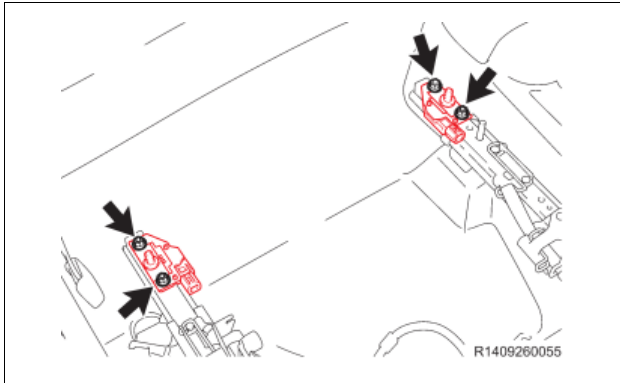

19. REASSEMBLE THE SEAT FRAME



THE OCS sensors are very sensitive and are easily damaged. DO NOT hit or force any part during reassembly.

a) Wipe off the OCS sensor mounting area.

b) Install the **NEW** left and right OCS sensors.

c) Reinstall 2 nuts on each side.

Torque: 25 N*m (255 kgf*cm, 18 ft.*lbf)

d) Reinstall the seat pan and temporarily reinstall the 2 nuts at the front so that they align with the markings.



• If the front seat cushion frame assembly is caught on a bolt and cannot be installed, loosen the nuts of the OCS sensor and reinstall it.

• If the nuts are not aligned with the markings, loosen the nuts of the OCS sensor and reinstall it.

• If you had to loosen the nuts for the OCS sensor, retorque to the correct value.

Torque: 25 N*m (255 kgf*cm, 18 ft.*lbf)

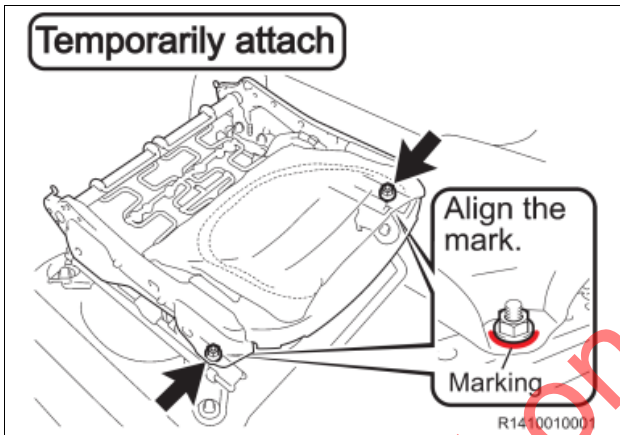

e) Temporarily reinstall the 2 rear nuts as shown.

f) Temporarily reinstall the collar and the nut.

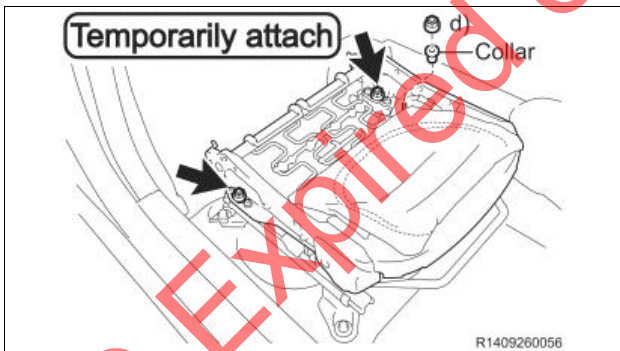

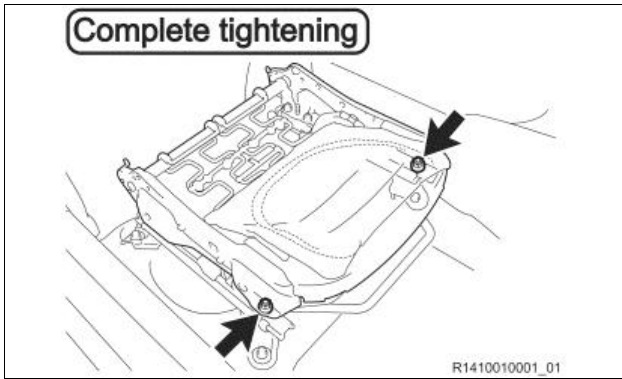

- g) Fully tighten the 2 front nuts.
Torque: 25 N*m (255 kgf*cm, 18 ft.*lbf)

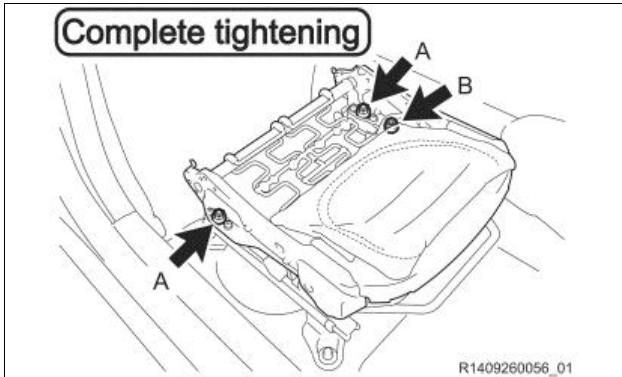

- h) Fully tighten the 3 rear nuts.
Torque:
Nut A:
37 N*m (377 kgf*cm, 27 ft.*lbf)
Nut B (w/ collar):
25 N*m (255 kgf*cm, 18 ft.*lbf)

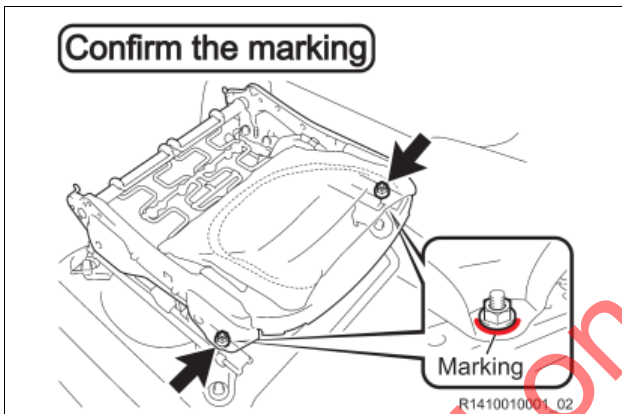

- i) Confirm that all markings are all lined up.

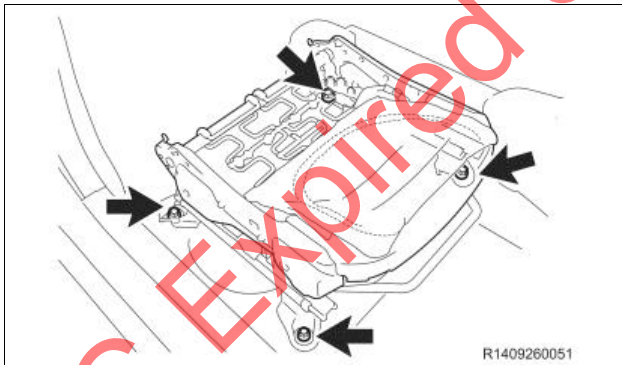

- j) Remove the 4 seat mounting bolts and remove the lower seat frame from the vehicle.

NOTE: When removing the lower seat frame be careful not to damage the vehicle.

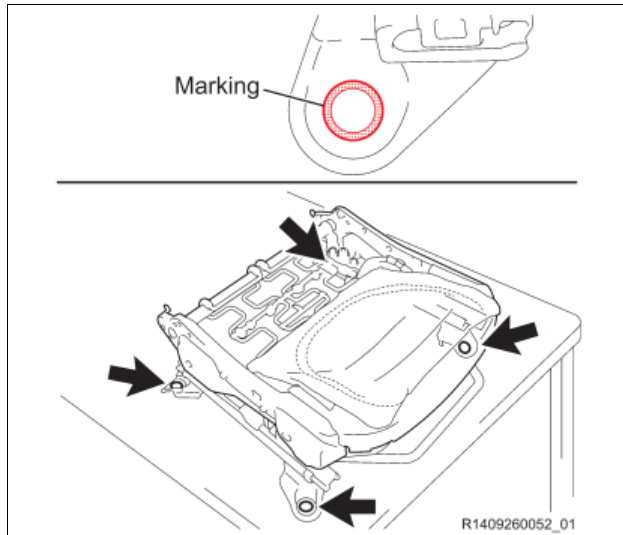

- k) Using a small amount of parts cleaner and a clean cloth, remove the markings from the seat mounting area.

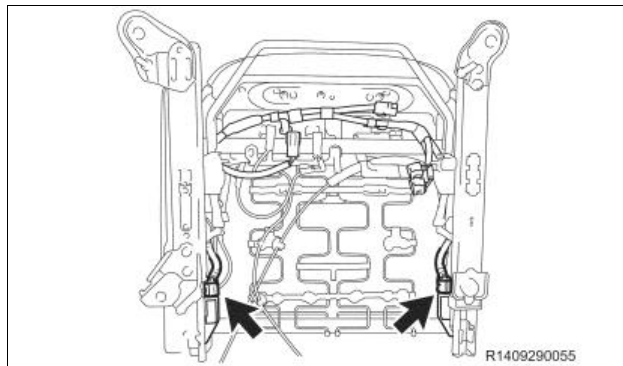

20. RECONNECT THE OCS SENSORS

- a) Reconnect the 2 connectors.



21. INSTALL THE OCS ECU



Never drop the ECU.
Replace the ECU with a NEW one if dropped, mark on the dropped ECU so it will not be reused.

NOTE: Some vehicles require the OCS ECU to be replaced. When the OCS ECU is replaced the owner's manual will also need to be updated see STEP 39. See <http://toyota-ocs.imagespm.info/> additional information.

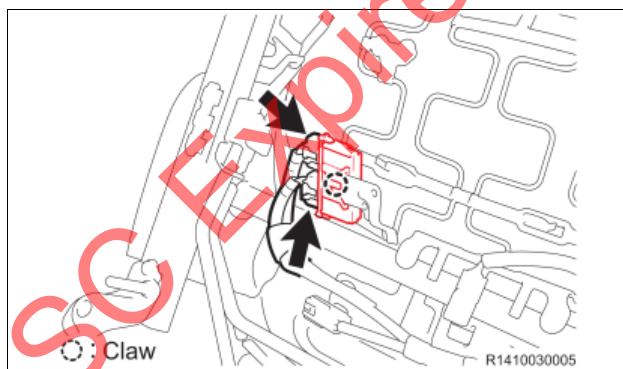

- a) Engage the claw to install the occupant detection ECU.
- b) Reconnect the 2 connectors.

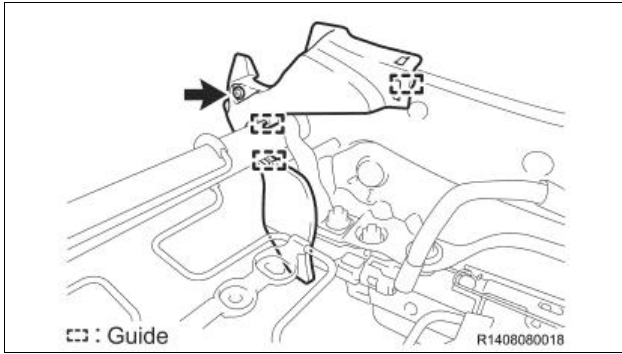

22. REINSTALL THE LEFT & RIGHT SEAT CUSHION EDGE PROTECTOR

- a) Reengage the 3 guides to reinstall the edge protector.
- b) Reinstall the screw.
- c) Repeat on the other side.

23. REINSTALL THE SEAT CUSHION AND COVER

- a) Check that the front seat airbag is not bent or folded (if equipped).

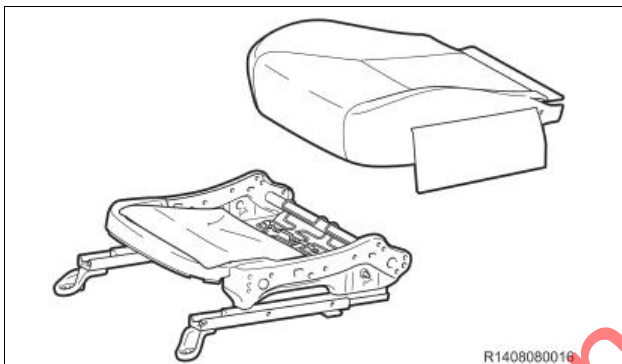
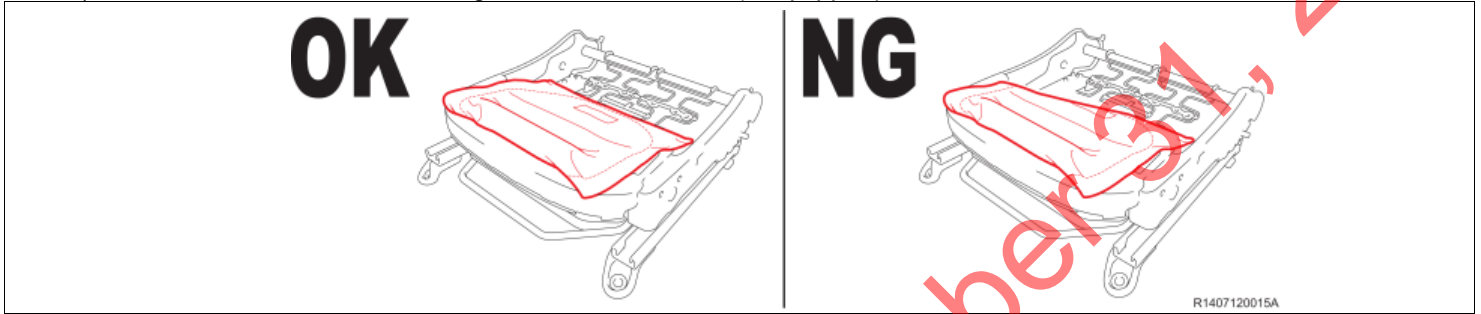

- b) Temporarily reinstall the seat cushion and cover onto the lower seat frame.

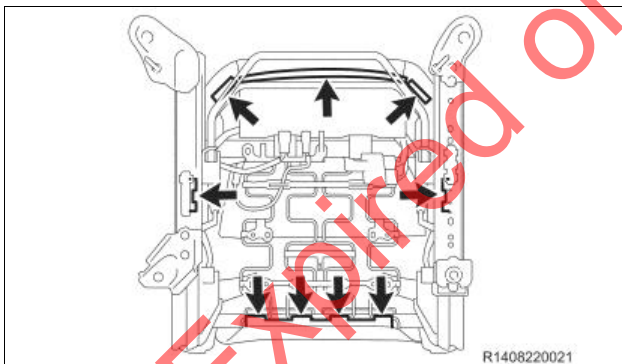

- c) Reengage the 9 hooks.

LSC Expired on December 31, 2017

24. REINSTALL THE SEATBACK

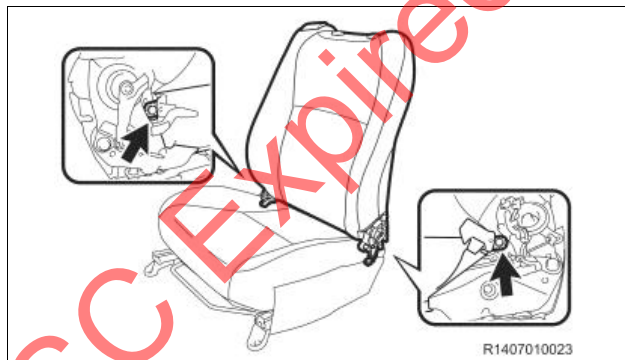
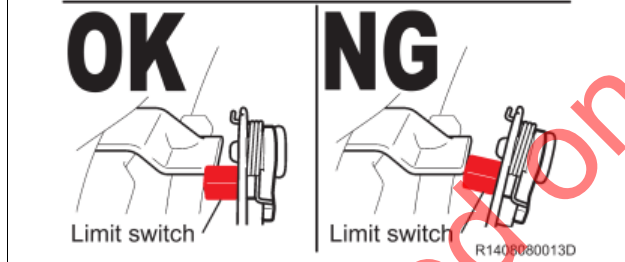
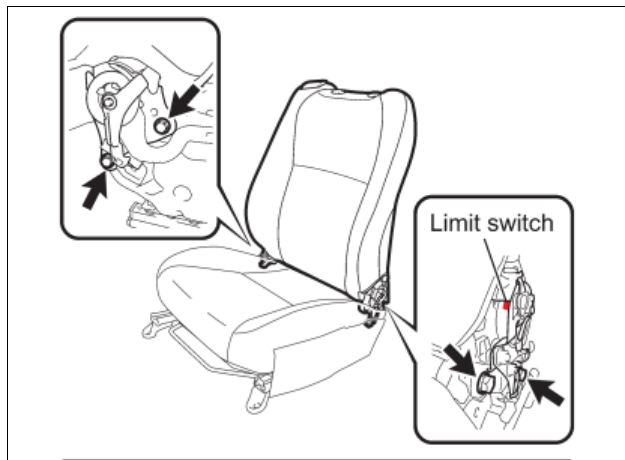
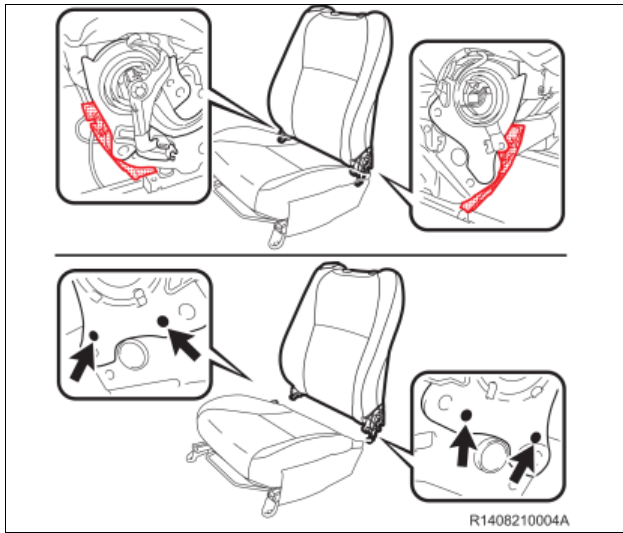

Do not to allow the seatback to interfere with the seat cushion edge protector.

- a) Reengage the 4 pins to reinstall the seatback onto the lower seat frame.

- b) Temporarily reinstall the 2 right bolts while holding the seatback.

- c) Temporarily reinstall the limit switch assembly with the 2 bolts from the left side.



Ensure that the limit switch spring is in the correct position, or an abnormal noise may occur.

- d) Tighten the 4 bolts.

Torque: 42 N*m (428 kgf*cm, 31 ft.*lbf)

- e) Reengage the 2 plastic rings.

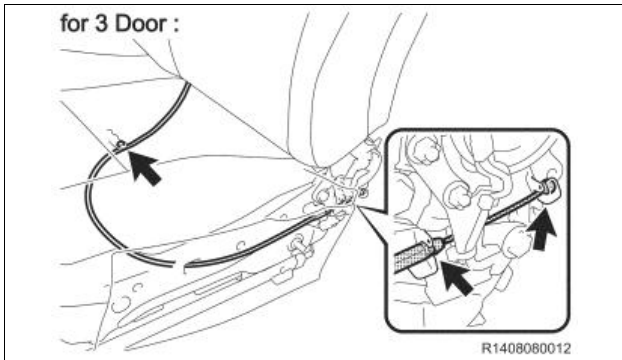

3 DOOR VEHICLES ONLY

1. Reengage the 2 clamps and the cable end to reinstall the seatback control cable.

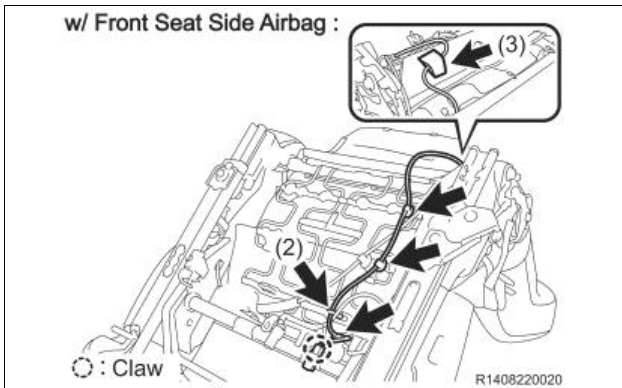

VEHICLES WITH SEAT AIRBAGS ONLY

1. Reengage the claw and the 3 clamps to reinstall the seat airbag wire harness.
2. Reengage the hook.
3. Reinstall the hook and loop fastener.

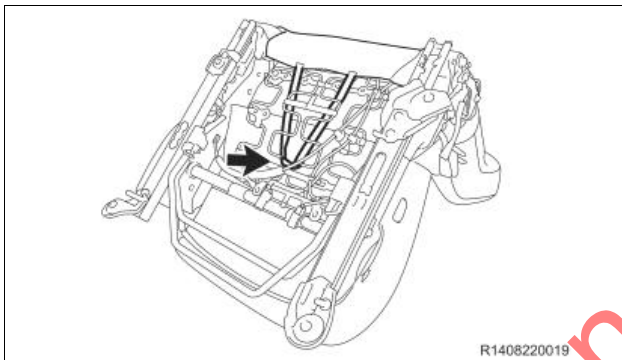

- f) Reinstall the seatback cover band.

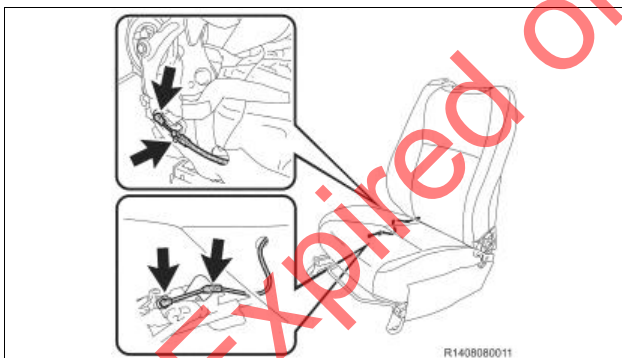

25. REINSTALL THE SEAT LOCK CONTROL CABLE ASSEMBLY 3 DOOR VEHICLES ONLY

1. Reengage the 2 clamps and the 2 cable ends to reinstall the seat lock control cable.

NOTE:

The seat lock control cable can be installed in either direction.

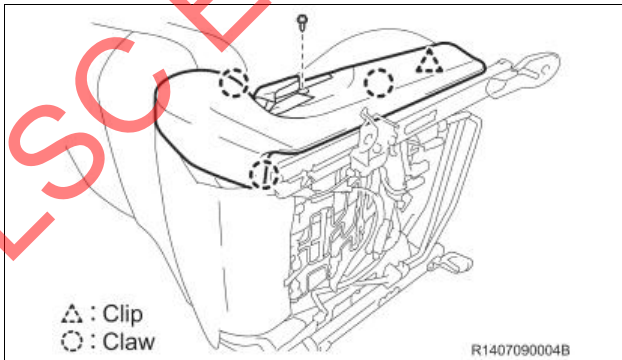

26. REINSTALL THE SEAT CUSHION SHIELD

- a) Reengage the clip and the 3 claws to reinstall the seat cushion shield.
- b) Reinstall the screw.

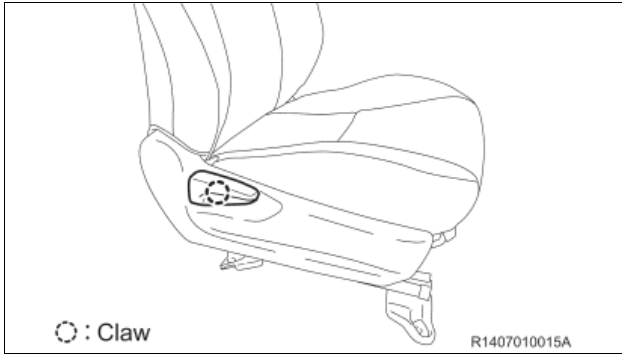

27. REINSTALL THE RECLINING ADJUSTER RELEASE HANDLE

- a) Remove the protective tape.
- b) Reengage the claw to reinstall the reclining release handle.

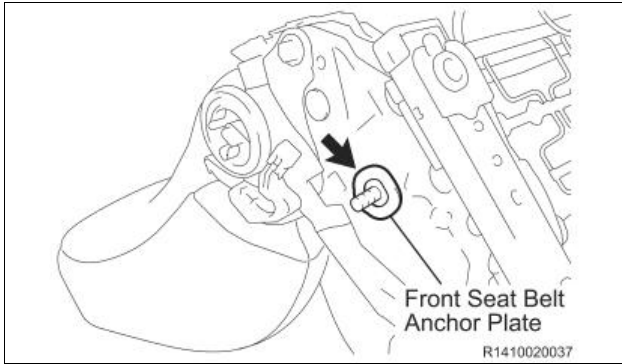

28. REINSTALL THE SEAT BELT BUCKLE

- a) Check that there is a front seat belt anchor plate attached.

- b) Align and hold the seat belt buckle in position.

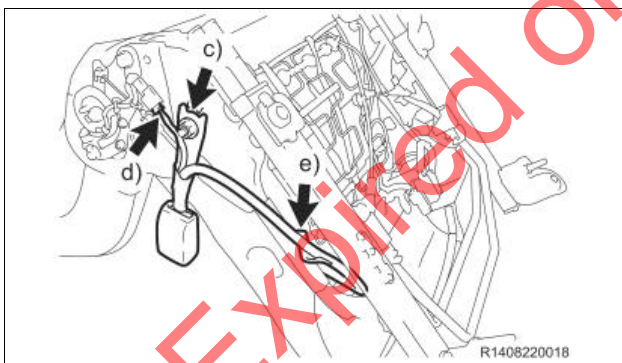

- c) Reinstall the seat belt buckle with the nut.
Torque: 42 N*m (428 kgf*cm, 31 ft.*lbf)
- d) Reconnect the connector.
- e) Reengage the clamp.

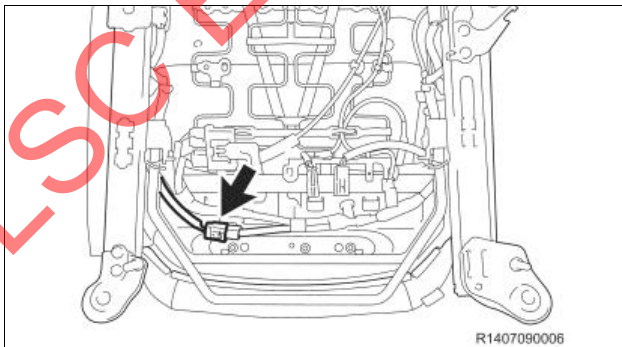

- f) Reconnect the connector.

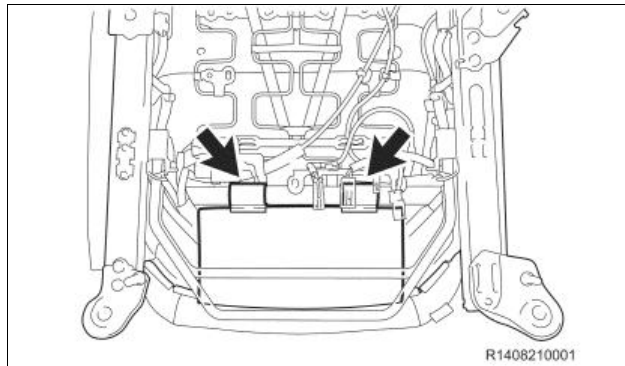

g) Reengage the 2 hooks.

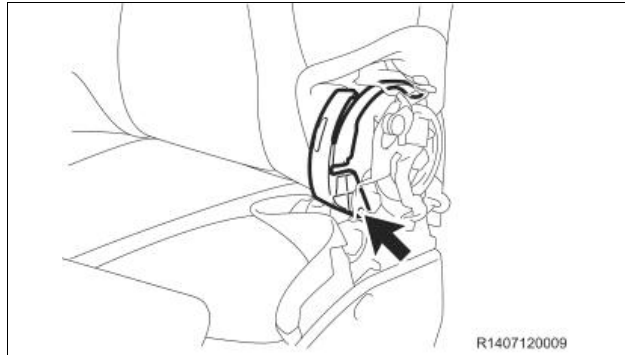

29. REINSTALL THE CUSHION INNER SHIELD

a) Check that the inside cover is secure.
If the inside cover is loose, fit it securely.

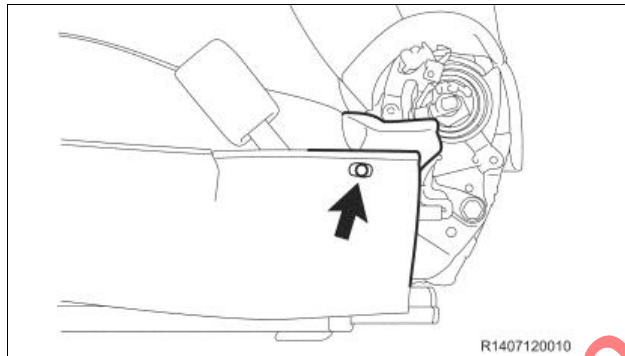

b) Align the holes of the 2 seat cover felt pieces with the hole of the frame.

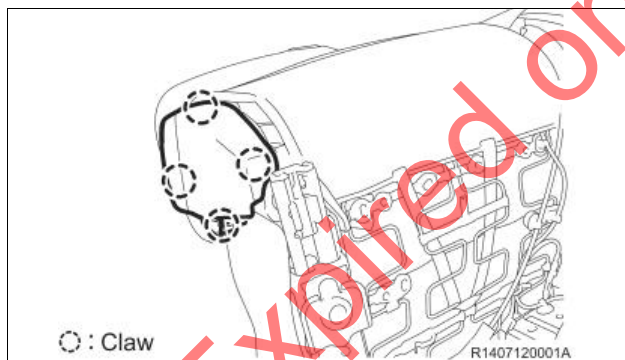

c) Reengage the 4 claws to reinstall the cushion inner shield.

30. REINSTALL THE RIGHT FRONT SEAT

a) Reinstall the right front seat.



- Follow the procedure described below in order to prevent the seat tracks from locking separately.
- DO NOT damage components during R&R front seat.
- 2 people may be required when installing the front seat into the vehicle.



NOTE: If the bolts are not tightened in the correct sequence, the alignment may be incorrect.

Torque: 37 N*m (377 kgf*cm, 27 ft.*lbf)

- b) Reinstall seat track covers (if equipped)
- c) Reinstall the headrest.

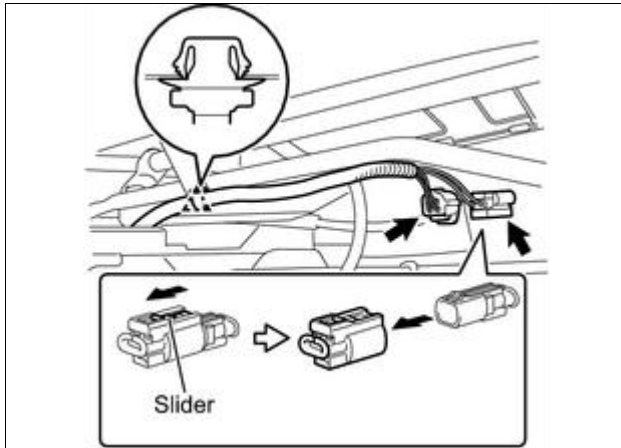

VEHICLES WITH SEAT AIRBAGS ONLY

1. Reconnect the SRS connectors.
2. Reconnect the OCS ECU connector.
3. Reinstall the harness clamp.

VEHICLES WITHOUT SEAT AIRBAGS

1. Reconnect the OCS ECU connector.

31. RECONNECT THE NEGATIVE BATTERY TERMINAL
32. REMOVE ANY PROTECTIVE COVERS
33. CHECK THE OPERATION OF THE PASSENGER AIRBAG ON/OFF INDICATOR
34. INSPECT THE SEAT OPERATION OF SEAT SLIDING & RECLINING



- Always perform inspection.
- In case of heavy sliding, abnormal noise, or locking failure of sliding/reclining, compared to before replacement, replace the separate type front seat cushion spring assembly with a **NEW** one.

35. CHECK FOR DTCs
36. PERFORM OCS ECU INITIALIZATION

- a) Perform zero point calibration and sensitivity check.

Refer to the Technical Information System (TIS), using the applicable vehicle and model year.

Hatchback

[2012](#)

[2013](#)

NOTE: If the standard value cannot be satisfied, change the weight position and perform check again.

37. REINITIALIZE SYSTEMS

- a) Restore any memory settings and initialize any system needed (i.e. power windows, moonroof, etc.)

38. RETURN THE SEAT TO THE ORIGINAL POSITION

39. UPDATE OWNER'S MANUAL (ONLY IF OCS ECU IS REPLACED)

- a) Locate owner's manual.

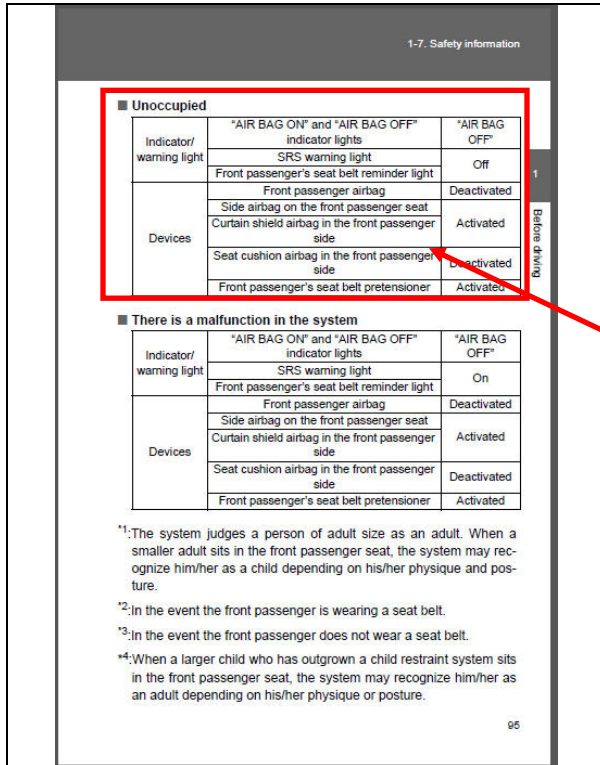

2012 MY VEHICLES ONLY

1. For 2012 MY vehicles go page 95.
2. Install the sticker to area shown.

■ Unoccupied

| Indicator/ warning light | "AIR BAG ON" and "AIR BAG OFF" indicator lights | "AIR BAG OFF" |
|--|--|------------------|
| | SRS warning light | |
| Front passenger's seat belt reminder light | | Off |
| Devices | Front passenger airbag | Deactivated |
| | Side airbag on the front passenger seat | Activated |
| | Curtain shield airbag in the front passenger side | |
| | Seat cushion airbag in the front passenger side | Deactivated |
| | Front passenger's seat belt pretensioner | Activated |

◀ VERIFY REPAIR QUALITY ▶

- Proper seat operation
- Proper passenger side airbag light operation

-If you have any questions regarding this OCS sensor replacement, please contact your regional representative.

VIII. APPENDIX

A. PARTS DISPOSAL

As required by Federal Regulations, please make sure all campaign parts (original parts) removed from the vehicle are disposed of in a manner in which they will not be reused, ***unless requested for parts recovery return.***

B. CAMPAIGN DESIGNATION DECODER

