

Installing Studs to Attach the Grabber Carriage Motors to the Grabber Carriage on the Zero Radius

Date: January 3, 2018
Bulletin Name: ZR-TSIB-012-A
Model: Zero Radius Model 48
Model Years: 2009 - 2017

Purpose:

This bulletin instructs to how remove the Zero Radius™ (ZR) grabber carriage motor bolts and replace with studs if the motor bolts are loosening.

Notice:

- This bulletin should be read and understood in its entirety before performing this update procedure.
- All procedures outlined in the bulletin must be performed by skilled service personnel. Refer to the product service manual for descriptions of maintenance procedures.

SAFETY NOTICE

Perform your company's Lockout/Tagout procedure. If your company does not have a Lockout/Tagout procedure, follow OSHA 1910.147 and 1910.146 Confined Space as appropriate.

SAFETY NOTICE

Use appropriate Personal Protective Equipment (PPE) as required by your company.

Equipment Required:

Customer to supply:

- Brake cleaner
- Electric drill and assorted drill bits
- 3/8"-16 tapered tap
- 3/8"-16 bottoming tap
- 3/8" tube brush
- Bristle brush
- Air compressor
- Rotary sander
- Rubber mallet
- Overhead crane or lifting device and chains
- Hydraulic fitting caps/plugs
- Loctite® 263 (or equivalent)
- Loctite® 515 (or equivalent)
- Loctite® 680 (or equivalent)
- 9/16" ratchet side wrench
- 9/16" wrenches and socket wrench
- Torque wrench
- Gloves (such as industrial nitrile gloves)
- Rolling head pry bar
- EP No. 2 lithium grease
- Wire brush

Parts Required:

Purchase from McNeilus Truck and Manufacturing, Inc. by calling 888-686-7278 or visiting www.streetsmartparts.com.

Item	Part Number	Description	Qty.
1	1580897	DOUBLE STUD, 3/8-16, 3/8-24, GR 8	8
2	0621024	WASHER, SPR, SPT .38 X .68 X .09 ZC	24
3	1141067	NUT, HEX, LKDT, .38-24 GC ZC	8
4	0120266	NUT, JAM, .38-24 GA ZC (For temporary use)	1
5	1427860	SCR, CAP, SOC .38-16 X 1.50 574 ZC	16

Procedure 1: Remove the Grabber Assembly from the Mast

1. Perform your company's Lockout/Tagout procedure. If your company does not have a Lockout/Tagout procedure, follow OSHA 1910.147 and 1910.146 Confined Space as appropriate.
2. Remove the grabber faceplate. Retain it and its hardware for reinstallation (Figure 1).

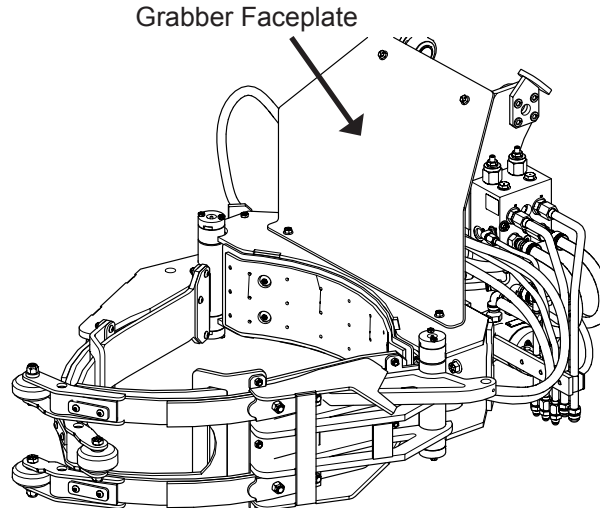

Figure 1

3. Attach chains and a crane to the grabber carriage assembly to support the assembly when it is removed from the mast.
4. Remove and retain all four grabber roller sets that hold the grabber carriage assembly to the mast — Figure 2 shows one of the top sets and Figure 3 shows the bottom sets. A set consists of a roller, bracket, and bolts (and proximity switch flag bracket if installed).
5. Inspect the rollers for wear and replace if necessary by calling 888-686-7278. If a roller needs to be replaced, it is recommended to replace all rollers at the same time.

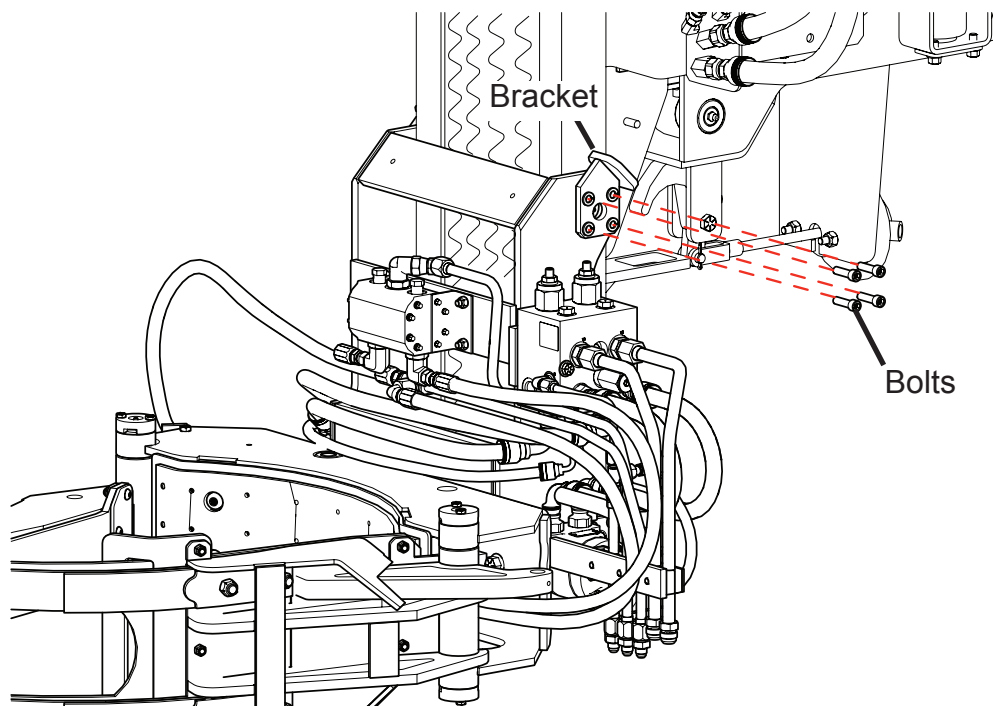

Figure 2

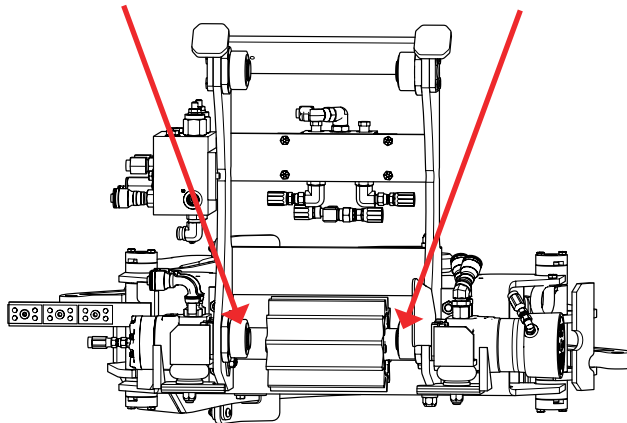

Figure 3

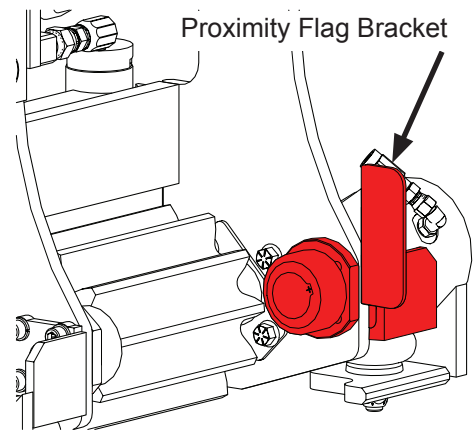

Figure 3 Close-up

6. Remove the hydraulic lines and plug fittings with caps. Retain all hydraulic lines and hardware as well as a record of the hydraulic line routing.
7. Remove the grabber carriage assembly from the mast and place the assembly on the ground or a work bench. Keep the chains/crane attached to the assembly for safety.
8. Remove and inspect the double check valve from the Over Center Manifold Valve for contaminants (location shown on Figure 4).
 - If contaminants are found or the double check valve is broken, stop working on this bulletin. The entire Over Center Manifold Valve block must be replaced before continuing with this bulletin. Contact McNeilus at 888-686-7278 or visit www.streetsmartparts.com to order a new Over Center Manifold Valve Block. Call a McNeilus National Service Representative at 888-686-7278 for installation information.
 - If contaminants are not found, replace the double check valve and continue with this bulletin.

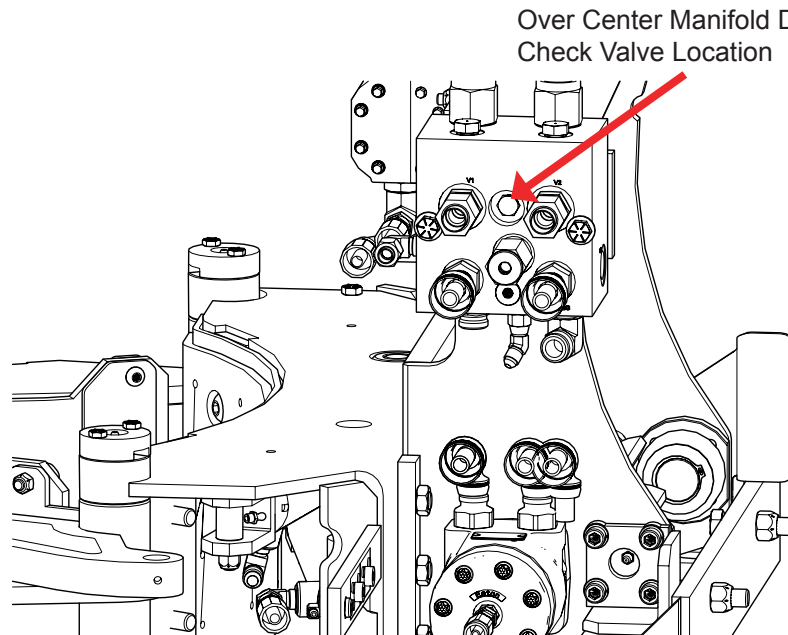

Figure 4

NOTE: The next steps detail work conducted on the backside of the grabber carriage assembly (see Figure 5).

9. If there are locking tabs that hold the bolts connecting the motors to the grabber carriage assembly, remove and discard the tabs from both motors.
10. Remove the motors, grabber gear, and all related hardware (Figure 5). Retain these items until further notice in this bulletin.
11. Inspect the motors, grabber gear, thrust washers (found near motor spline), motorshaft support bearing, and 4-hole bearing retainer plate for damage. If damage is found, stop working on this bulletin and order a new part by calling 888-686-7278 or visiting www.streetsmartparts.com. Continue with this bulletin once you have the new part.

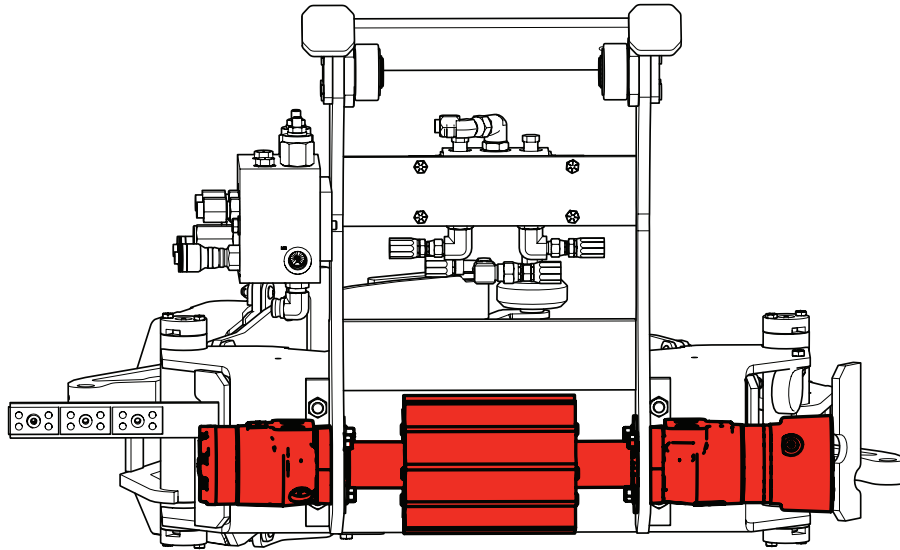

Figure 5

Procedure 2: Cleaning Procedures

2.1 Cleaning the Grabber Carriage Assembly

1. Residual Loctite must be removed from specific bolt holes. On each side of the grabber carriage assembly, at the location where the motors attach to the grabber assembly, clean the four (4) bolt holes and the large hole for the motor shaft.
 - a. Start by cleaning inside the bolt holes with a tube brush on an electric drill (see Figure 6 for location of holes). Clean the bolt holes on **both sides of the grabber assembly** where the motors are bolted onto the grabber assembly. The residue from the Loctite is hard and is a contaminate for the installation of the new hardware if it is left in place. The holes are clean when all of the Loctite is removed; do not grind the holes.
 - b. Clean the large hole for the motor shaft (see Figure 6) with a tube brush on an electric drill. Clean both of the large holes on **both sides of the grabber assembly**. The holes are clean when all of the Loctite is removed; do not grind the holes.
 - c. Use a rotary sander on the outside and inside of the cleaned area to remove rust, paint, or other contaminates.

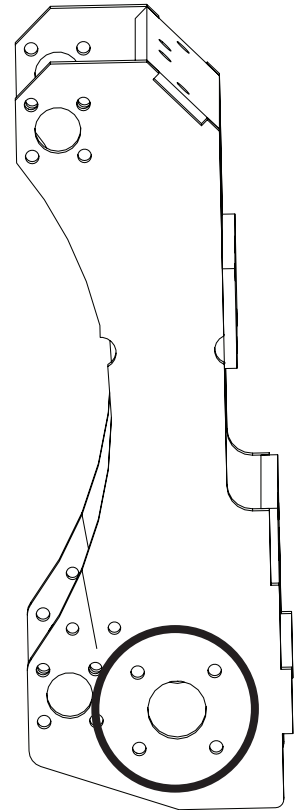

Figure 6

2.2 Cleaning the Motors and Grabber Rollers

1. Set the motors upright with the mounting holes facing upright (Figure 7).
2. Use a clean 3/8"-16 tapered tap and an electric drill to push the tap into each mounting hole and back out to clean the holes of contaminates.
3. Use a clean 3/8"-16 finishing tap and electric drill to push the tap into each mounting hole and back out to clean the holes of contaminates.
4. Repeat Steps 2 and 3 on the other motor.



Figure 7

5. Wear gloves for the next cleaning steps. Spray the brake cleaner in the mounting holes and on top of the flange of both motors. The brake cleaner removes the rust inhibitor on the motor and any remaining contaminates so Loctite will adhere to the motor flange.
6. Use a clean 3/8" tube brush and the electric drill to clean each mounting hole. **DO NOT put the drill in reverse** — the brush will get stuck in the mounting hole. **Instead, pull the brush out of the mounting holes.**
7. Turn the motors on their sides to drain the brake cleaner into an appropriate containment pad or berm.
8. Spray more brake cleaner on the top of the motor flange and into the mounting holes.
9. Clean the area with the bristle brush (see Figure 8). **DO NOT** use a wire brush on the seal in the shaft.



Figure 8

10. Repeat Steps 5-9 of the Motor Cleaning Procedure until all mounting holes are clean and the area is free from rust inhibitor and oil/contaminates.
11. Use compressed air on the motors to push out any remaining contaminates from the mounting holes and to dry the flanges of the motors. The flanges should be free from oil residue and should be a dull gray color with no shine.
12. Use a rotary sander on the flat surface (mating side) of each 4-hole retainer plate to clean it.
13. Spray brake cleaner on the flat side of each 4-hole retainer plate. Then spray them with compressed air to remove contaminates and to dry the retainer plates.
14. Clean the grabber roller thread holes with a clean 3/8"-16 tapered tap and an electric drill to push the tap into each mounting hole and back out and with a clean 3/8"-16 finishing tap and electric drill to push the tap into each mounting hole and back out to clean the holes of contaminates.
15. Clean the roller thread holes with a wire brush.

Procedure 3: Installation of Motors and Grabber Gear

Because of the application of Loctite®, it is important you get all of the necessary items ready for installation before beginning the procedure.

You will need:

- Eight (8) double end studs (PN 1580897)
- Twenty-four (24) washers (PN 0621024)
- Eight (8) locknuts (PN 1141067)
- One (1) temporary jam nut (PN 0120266)
- Brake cleaner
- Air compressor
- Loctite® 680
- Loctite® 263
- Loctite® 515
- Sixteen (16) bolts (PN 1427860)

3.1 Installing Motor Components

1. Stand the motors upright with the mounting holes facing up.
2. Clean the studs with the brake cleaner and air compressor.
3. Inspect the existing motorshaft support bearings for quality. If the inside race turns freely, the bearing can be reused. If not, purchase and replace with a new bearing (PN 1414603). Clean the bearing outer diameter (Figure 12) with brake cleaner and compressed air to remove contaminants.
4. Apply one (1) drop of Loctite 263 in each stud mounting hole on the flange side of both motors. Do not apply more than one drop. Excessive Loctite in the holes of the motor will not allow the studs to install completely.
5. Apply Loctite 515 to the top of the flange on each motor (Figure 9). **DO NOT** get Loctite in the mounting holes. **DO NOT** get Loctite on the shaft seal.



Figure 9

Apply Loctite 515 to the flange of each motor.

6. Apply one (1) drop of Loctite 263 on the coarse thread end of a stud (PN 1580897). Do not apply more than one drop. Excessive Loctite in the holes of the motor will not allow the studs to install completely.
7. Screw the coarse thread end of the stud into the mounting hole of a motor (Figure 10).
8. Install one (1) temporary jam nut halfway down on the fine thread end of the stud (Figure 10).
9. Install one (1) temporary locknut (PN 1141067) on top of the jam nut (Figure 10). Finger tighten the nuts until they meet.
10. Use 9/16" wrenches on each nut and tighten the jam nut to the backside of the locknut.
11. Use a torque wrench on the locknut to torque the stud into the motor at 37 ft.-lbs. This will seat the coarse thread end of the stud into the motor.
12. Use a 9/16" wrench on each nut to loosen the jam nut and remove each temporary nut off the fine thread end of the stud without compromising the seating of the stud.

13. Repeat Steps 6-12 on the remaining three (3) studs of this motor and again for the other motor and (4) studs.

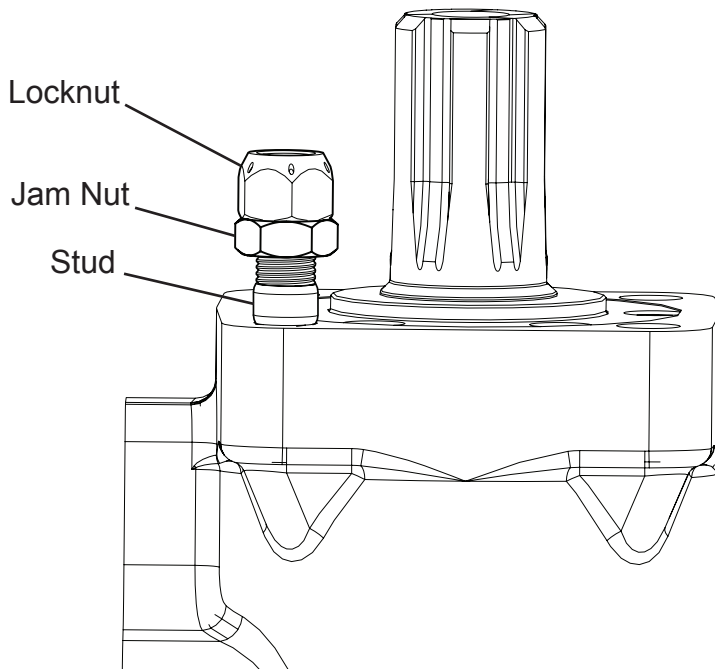

Figure 10

14. Apply Loctite 515 Gasket Eliminator on the flat side (mating side) of each 4-hole bearing retainer plate (Figure 11).



Figure 11

Apply Loctite 515 to the 4-hole bearing retainer plate.

15. Apply Loctite 680 on the (flat) **outside edge** of the motorshaft support bearings (see Figure 12 and Figure 13).
16. Insert the motorshaft support bearing into the large motor shaft hole on the grabber carriage assembly (the hole you already prepped) (see Figure 6). Use the bearing retainer to assist in locating the bearing position. Do this on both motor shaft holes — one bearing per large hole.



Figure 12



Figure 13

*Insert the support bearing in the large hole that is already prepped.
NOTE: The visible green gel is Loctite 680.*

3.2 Installing the Motors and Grabber Gear on the Grabber

NOTE: The drive motor is **always placed on the left side** and the brake motor is **always placed on the right side** of the grabber carriage assembly when you are facing the back of the grabber assembly.

1. Install the 4-hole bearing retainer plate to the **inside of the grabber carriage assembly over the motorshaft support bearing** (Figure 14). The Loctite applied side of the plate must be against the grabber carriage assembly. The large hole in the bearing retainer plate matches the location with the large hole on the grabber assembly. **Repeat on the other inside side of the grabber carriage assembly.**
2. **Drive Motor:** Install the **drive motor** in place on the grabber carriage assembly on the **left side** (Figure 14). Install the motor just enough to allow the thrust washer (when it is installed in the next step) to hang on the shaft.

NOTE: Remember the **hydraulic tube ports on the motor must be facing UP**. The motor's flange side with the Loctite must be placed flush against the outside of the carriage assembly with the motor spline pushed through the large hole.

3. Install a thrust washer in place around the drive motor spline on the **inside side** (Figure 14).

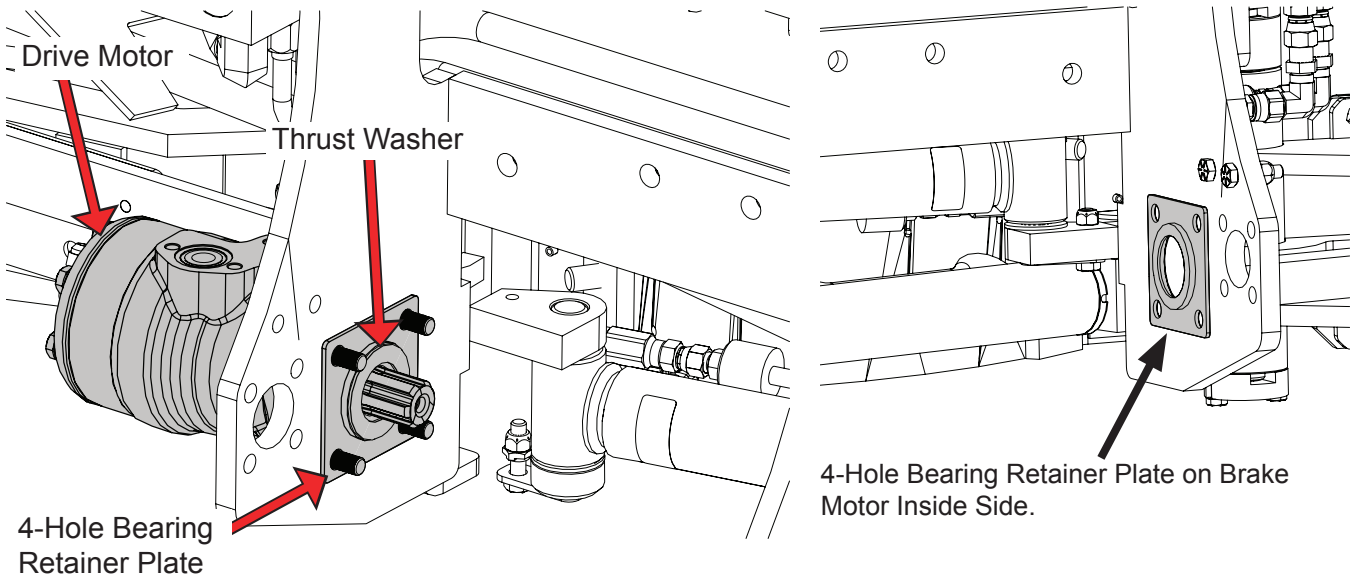

Figure 14

Install the drive motor with the spline going through the large hole. Add the thrust washer.

4. Install the grabber gear onto the drive motor spline (Figure 15).

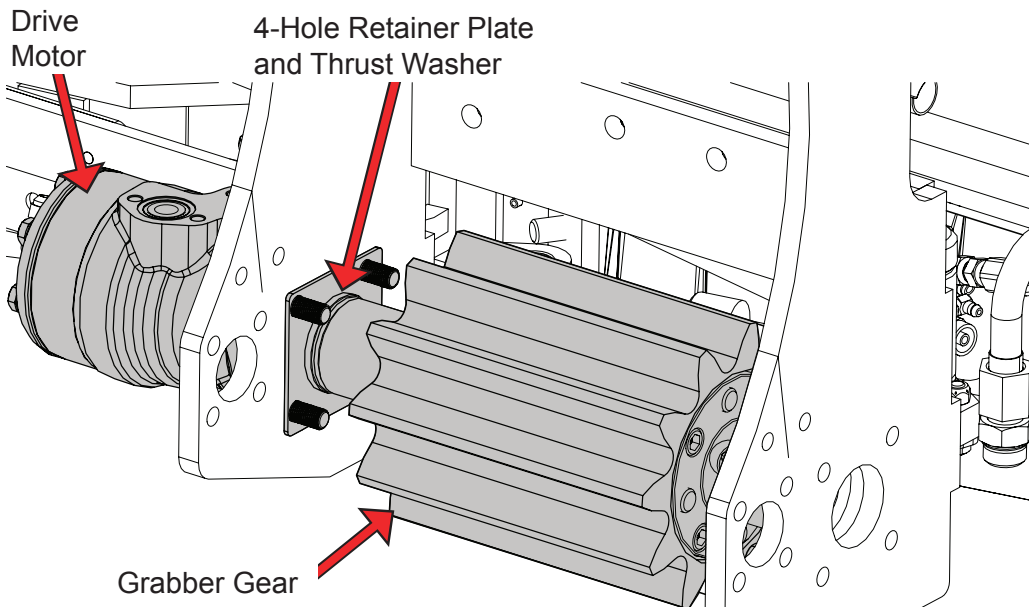

Figure 15

5. Apply one (1) drop of Loctite 263 to each stud. Do not apply more than one drop.
 6. Install a washer (PN 0621024) and a nut (PN 1141067) per stud (on the fine threaded end of the stud) on the **drive motor** (Figure 15).
 7. Hand tighten the nuts to the 4-hole retainer plate as needed to make sure the motor and grabber gear stay where placed and still allow the gear to be wiggled to allow installation of the brake motor.
 8. **Brake Motor:** Install the **brake motor** on the right side of the grabber assembly. Do not push the motor flush against the grabber assembly until the thrust washer is installed (see Step 9) (Figure 16). It may be necessary to turn the drive motor enough to correctly position the spline to allow the brake motor to be installed.
- NOTE:** Remember the **hydraulic tube ports on the motor must be facing UP**. The motor's flange side with the Loctite must be placed flush against the outside of the carriage assembly with the motor spline pushed through the large hole.
9. Install a thrust washer in place around the brake motor spline (Figure 16).

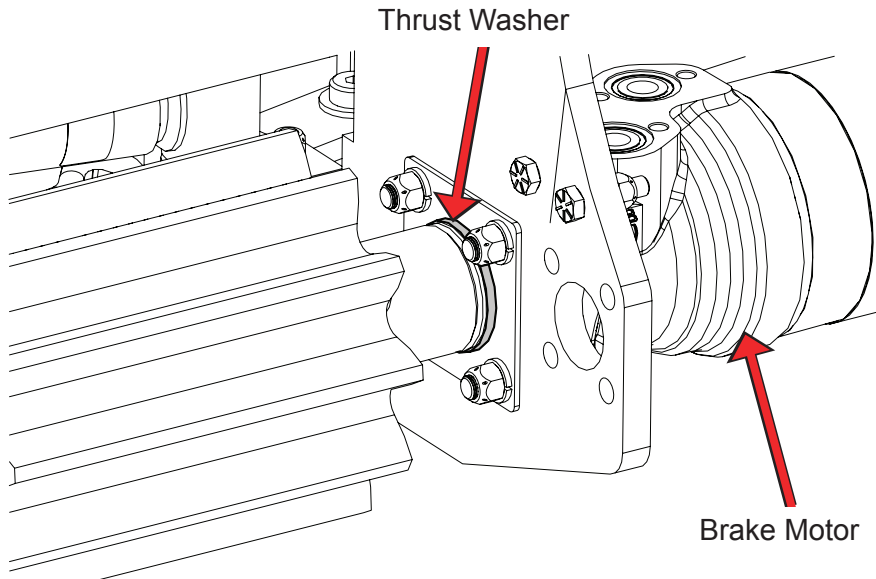

Figure 16

Install the thrust washer between the spline of the brake motor and the grabber gear.

10. Apply one (1) drop of Loctite 263 to each stud. Do not apply more than one drop.
11. Install a washer (PN 0621024) and a locknut (PN 1141067) per stud on the fine threaded end on the brake motor (Figure 16).
12. Once the motor splines are aligned, use a rubber mallet to push the splines into the grabber gear, then seat the motor.
13. Hand tighten the nuts on the studs as needed to make sure the motor and grabber gear stay where placed.
14. Use the ratchet side wrench to tighten all nuts on studs.
15. Use a torque wrench with a 9/16" socket to tighten the studs to 37 ft.-lbs. Do this in a crisscrossing tightening pattern (Figure 20).

*Tightening
Pattern*

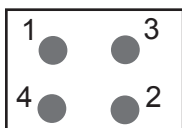

Figure 17

16. Strike against the ends of both motors using the rubber mallet in order to seat all parts again.
17. Use the torque socket wrench again to tighten the bolts to 37 ft.-lbs.
18. Repeat Steps 16 and 17 until there is no movement from the socket wrench.
19. Center the grabber gear by placing a rolling head (centering) pry bar through the open hole next to the motor/ grabber gear on the grabber assembly contacting the metal part of the grabber gear (Figure 18) — **Not Against the Plastic Grabber Gear!** Strike the pry bar with the rubber mallet to center the grabber gear. Striking and aligning the motors may force the grabber gear into misalignment. Striking the grabber gear will realign it to the center.



Figure 18

20. Grease the couplers on the gear with EP No. 2 lithium grease (Figure 19).

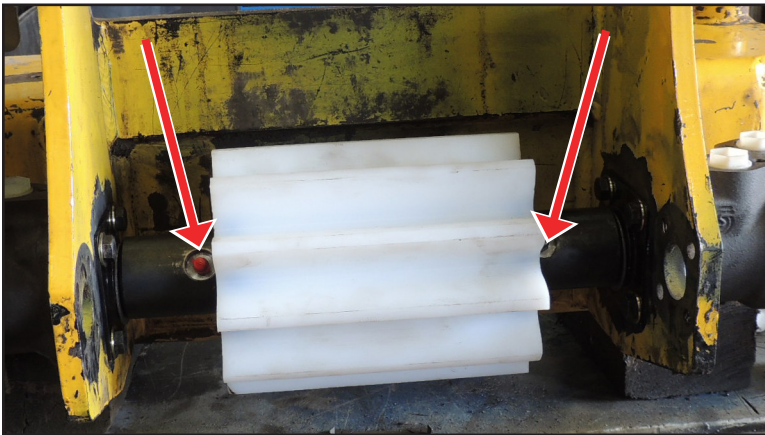

Figure 19
Grease points.

21. If you replaced an existing motor with a new motor, remove the shipping plug and washer before installing hydraulic lines (Figure 20).



Figure 20

22. Use the crane to position the grabber assembly in location on the ZR mast.
23. Reinstall all four roller sets: the bracket (the upper brackets have an angled bump stop; the lower brackets do not), roller (if it slid out during disassembly from the mast).
24. Apply one (1) drop of Loctite 263 to the **new** bolts (PN 1427860) and washers (quantity 16) (PN 0621024) and install them in each roller.
25. Use a torque wrench to torque each bolt to 38 ft.-lbs.
26. Reinstall the proximity switch flag bracket and hardware if previously installed.
27. Use a torque wrench to torque each bolt to 23 ft.-lbs.
28. Remove the chains and crane.
29. Route and reattach all hydraulic lines on the grabber assembly in the correct routing positions.
30. Remove your company's Lockout/Tagout procedure. If your company does not have a Lockout/Tagout procedure, follow OSHA 1910.147 and 1910.146 Confined Space as appropriate.
31. Run the arm and grabber functions, checking for proper function.
- If the arm and grabber do not function correctly, call a McNeilus National Service Representative at 888-686-7278 for further instruction.
32. Check for leaks at the hydraulic fittings. Tighten fittings as needed.
33. Reinstall the grabber faceplate using the retained hardware.
34. Use a torque wrench to torque bolts to 15 ft.-lbs.
35. Return vehicle to service after ensuring there are no leaks and the arm and grabber function correctly.

Continuous Improvement:

The change included in this document is part of the McNeilus Continuous Improvement Process.

McNeilus's quality policy is providing customer satisfaction through innovative products, dedicated service, and a constant focus on continuous improvement.



(888) 686-7278

www.streetsmartparts.com