

REFERENCE:	Nova Bus Manuals
SECTION:	11: Fuel and Exhaust
RS N° :	MQR 7621-1093
EFFECTIVÉ PROD. :	NA

APPLICATION DEADLINE:N/A

SUBJECT:	Cummins code 3568
JUSTIFICATION:	Possibility of engine derating, stalling and losing of power.

LEVEL	DESCRIPTION	DIRECT CHARGES		TIME
		LABOUR	MATERIAL	
1	Retrofit routing of DEF, engine coolant hoses	Client	Client	-
2	-	-	-	-

MATERIAL

QTY	PART N°	REV.	DESCRIPTION	REPLACES PART N°
LEVEL 1				
1	N56339	-	TIE WRAP	-
1	N75961	-	CONNECTOR	-
1	N90005	-	ADAPTER QUICK CONNECTOR 90°	-
2	N40492	-	BOLT	-
1	N90018	-	BRACKET	-
1	N87985	-	BRACKET	-
1	N87984	-	BRACKET	-
2	N90007	-	BRACKET	-
1	N95827-35	-	HOSE	-
3.33 LF	N57243-02	-	Sleeve reflective	-
3	N57634-01	-	CRIMP STEPLESS	-
3	N57807	-	MOUNT FIRE	-
3	N38593	-	NUT	-
2	N31320-04	-	P-CLAMP	-
3	N56339	-	TIE WRAP	-
1	NT08134	-	POSTIONING JIG	-
LEVEL 2				
-	-	-	-	-

To order, please contact Prevest Parts by phone at 1-800-771-6682, by fax at 1-888-668-2555 or by email at prevostparts.commands@volvo.com. Specify document number, quantity of parts required and shipping address.

DISPOSAL OF PARTS

REMOVED PARTS ARE:	DISCARDED*	RETAINED	* Dispose of the unused parts and the defective parts in accordance with local environmental standards in effect.
	Yes	–	

REVISION HISTORY

REV.	DATE	CHANGE DESCRIPTION	WRITTEN BY
NR	2018JA22	Initial release	Kumaraswamy K S

CLIENT	ORDER	ROAD NUMBER		VIN (2NVY/4RKY...)		QTY
		FROM	TO	FROM	TO	
Ames Transportation Agency - Iowa	L904	6101	6104	S92J1G9775221	S92J7G9775224	4
Austin - CMTA - Texas	L704	5051	5068	L82J7E4500471	L82J2E4500488	18
Austin - CMTA - Texas	LA17	5101	5107	S92J2H9775763	S92J3H9775769	7
Austin - CMTA - Texas	LA18	5151	5158	L82J0H9775770	L82J3H9775777	8
Barrie - Ontario	L878	1501	1504	L82JXF3001691	L82J6F3001719	4
Barrie - Ontario	L955	1601	1604	L82J7G9775408	L82J9G9775412	4
Barrie - Ontario	LA31	1701	1705	L82J0H9775817	L82J2H9775821	5
BC Transit - BCT - British Columbia	L858	9447	9481	L82JXE3001401	L82J5F3001436	35
BC Transit - BCT - British Columbia	L891	—	—	L82J5F3001565	L82J2F3001569	5
Bow Valley Transit - Alberta	L993	—	—	L82JXG3750329	L82J6G3750330	2
Bow Valley Transit - Alberta	LA26	—	—	L82J4H3750473	L82J4H3750473	1
Brampton - Ontario	L789	1401	1408	L82J4E3001216	L82J1E3001223	8
Brampton - Ontario	L816	1409	1415	L82J3E3001224	L82J9E3001230	7
Brampton - Ontario	L864	1501	1510	L82JXF3001500	L82J6F3001509	10
Brampton - Ontario	L865	1511	1519	L82JXF3001514	L82J9F3001522	9
Brampton - Ontario	L941	1614	1623	L82J1G3750123	L82J2G3750132	10
Brampton - Ontario	L942	1601	1613	L82J6G3750070	L82J4G3750083	13
Brampton - Ontario	LA20	1707	1713	L82J5H3750532	L82J6H3750538	7
Brampton - Ontario	LA21	1701	1706	L82J8H3750539	L82J1H3750544	6
Brandon - Manitoba	L899	67	70	L82J2G3750180	L82J8G3750183	4
Brantford - Ontario	L775	10131	10132	L82U1D3000999	L82U2D3001000	2
Brantford - Ontario	L928	10151	10153	L82J7F3001793	L82J0F3001795	3
Brantford - Ontario	LA03	10161	10612	L82J0G3750369	L82J7G3750370	2
Burlington - Ontario	L887	7017-15	7025-15	L82J7F3001681	L82J8F3001723	9
Cape Breton Nova Scotia	LA12	7092	7093	L82J8H3750587	L82JXH3750588	2
Chicago Transit Authority - CTA - Illinois	L773	—	—	L82JXD4500429	L82J6D4500430	2
Chicago Transit Authority - CTA - Illinois	L811	7902	7949	L82J6E4500509	L82J4E4500556	48
Chicago Transit Authority - CTA - Illinois	L837	7950	7999	L82J6E4500655	L82J1E4500708	50
Chicago Transit Authority - CTA - Illinois	L847	8000	8049	L82J1E4500773	L82JXE4500822	50
Chicago Transit Authority - CTA - Illinois	L848	8050	8099	L82JXF4500823	L82J1F4500872	50
Chicago Transit Authority - CTA - Illinois	L849	8100	8149	L82J5F4500874	L82J3F4500923	50
Chicago Transit Authority - CTA - Illinois	L850	8150	8199	L82J5F4500924	L82J6G9775013	50
Chicago Transit Authority - CTA - Illinois	L943	8200	8324	L82JXG9775225	L82J3G9775406	125
Cornwall Ontario	L935	—	—	L82J3F3001838	L82J5F3001839	2
CT Transit - Connecticut	L814	1462	1473	S92LXE4500717	S92L4E4500728	12
CT Transit - Connecticut	L815	1426	1429	S92L0E4500709	S92L0E4500712	4
Démo US	LA13	—	—	L82J4G9775611	L82J5G9775620	10
Démo-2017	L980	—	—	L82J1G9775565	L82J9G9775569	3
Duke University - North Carolina	L938	—	—	L82L8G9775399	L82L0G9775400	2

CLIENT	ORDER	ROAD NUMBER		VIN (2NVVY/4RKY...)		QTY
		FROM	TO	FROM	TO	
Duke University - North Carolina	LA38	—	—	L82L9H9775994	L82L9H9775994	1
Durham Region Transit - Ontario	L872	8551	8553	L82J0F3001523	L82J4F3001525	3
Durham Region Transit - Ontario	L888	8554	8559	L82J2F3001703	L82J1F3001708	6
Durham Region Transit - Ontario	L996	8560	8563	L82J1G3750414	L82J7G3750417	4
Durham Region Transit - Ontario	LA19	8564	8565	L82J9G3750418	L82J0G3750419	2
Fredericton - New Brunswick	L774	8131	8131	L82U7D3000960	L82U7D3000960	1
Fredericton - New Brunswick	L812	—	—	L82J4E3001202	L82J4E3001202	1
Fredericton - New Brunswick	L836	8143	8143	L82J9E3001390	L82J9E3001390	1
Fredericton - New Brunswick	L901	8151	8151	L82J7F3001602	L82J7F3001602	1
Fredericton - New Brunswick	L968	8161	8162	L82J1G3750218	L82J3G3750219	2
Fredericton - New Brunswick	LA15	8171	8174	L82J1H3750589	L82J1H3750592	4
Grande Prairie Alberta	L834	—	—	L82J7E3001386	L82J2E3001389	4
Guelph - Ontario	L767	237	239	L82UXD3000967	L82U3D3000969	3
Guelph - Ontario	L835	240	243	L82J0E3001391	L82J6E3001394	4
Guelph - Ontario	L927	244	247	L82J1F3001756	L82J9F3001763	4
Guelph - Ontario	L985	248	251	L82J7G3750255	L82J2G3750258	4
Houston - Texas	L951	1915	1915	L82J0G9775203	L82J0G9775203	1
Houston - Texas	L952	1580	1580	S92J5G9775318	S92J5G9775318	1
Houston - Texas	L981	1916	1994	L82J8G9775434	L82J4G9775513	79
Houston - Texas	L982	1581	1599	S92J5G9775514	S92J5G9775545	19
Kingston Ontario	L880	1502	1502	L82JXF3001786	L82JXF3001786	1
Kingston Ontario	L889	1687	1689	L82J1G3750252	L82J5G3750254	3
Kingston Ontario	L925	1504	1510	L82J5F3001808	L82J5F3001811	4
Kingston Ontario	L954	1683	1686	L82J4G3750259	L82J4G3750262	4
Lethbridge - Alberta	L868	—	—	L82J2F3001510	L82J2F3001510	1
Lethbridge - Alberta	L997	181	186	L82J5G9775570	L82JXG9775578	6
LYNX - Florida	L785	—	—	S92L6E4500505	S92L8E4500506	2
Milton - Ontario	L884	1701	1702	L82J0G3750338	L82J2G3750339	2
Moncton (Codiac) - New Brunswick	LA06	—	—	L82J3G9775552	L82JXG9775564	9
NFTA - Buffalo, New York	LA30	1717	1724	L82J8H9775838	L82J5H9775845	8
Niagara Falls - Ontario	L771	1396	1397	L82U9D3000958	L82U0D3000959	2
Niagara Falls - Ontario	L987	1601	1604	L82J6G3750344	L82J1G3750347	4
North Bay - Ontario	L895	784	785	L82J7F3001678	L82J9F3001679	2
North Bay - Ontario	L979	786	787	L82J4G3750312	L82J6G3750313	2
Oakville - Ontario	L874	—	—	L82J6F3001526	L82JXF3001531	6
Oakville - Ontario	L881	—	—	L82J2F3001717	L82J8F3001740	5
Oakville - Ontario	L945	—	—	L82J9G3750211	L82JXG3750217	7
Orillia Ontario	L965	1722	1724	L82J3G3750320	L82J7G3750322	3
Peterborough - Ontario	L770	55	60	L82U0D3000993	L82UXD3000998	6
Peterborough - Ontario	L870	61	63	L82JXF3001612	L82J3F3001614	3
Peterborough - Ontario	L919	64	66	L82J6F3001767	L82JXF3001769	3

CLIENT	ORDER	ROAD NUMBER		VIN (2NVY/4RKY...)		QTY
		FROM	TO	FROM	TO	
Peterborough - Ontario	L966	67	71	L82J2G3750230	L82JXG3750234	5
Red Deer - Alberta	L766	1104	1105	L82U7D3001025	L82U9D3001026	2
Red Deer - Alberta	L772	1106	1108	L82J2E3001120	L82J6E3001122	3
Red Deer - Alberta	L813	10008	10009	L82J2E3001361	L82J4E3001362	2
Red Deer - Alberta	L869	—	—	L82J9F3001570	L82J0F3001571	2
Red Deer - Alberta	L926	—	—	L82J2F3001796	L82J4F3001797	2
Regina - Saskatchewan	L776	663	669	L82U4D3001001	L82U5D3001007	7
Regina - Saskatchewan	L807	671	685	L82J8E3001137	L82J2E3001151	15
Regina - Saskatchewan	L892	686	691	L82J5F3001484	L82J4F3001489	6
Regina - Saskatchewan	L949	692	696	L82J3G3750205	L82J0G3750209	5
Regina - Saskatchewan	L992	—	—	L82J6G3750294	L82J3G3750298	5
Sarnia Ontario	L873	151	152	L82J0F3001599	L82J0F3001600	2
Sarnia Ontario	L883	153	153	L82J4G3750021	L82J4G3750021	1
Sarnia Ontario	L963	162	162	L82J7G3750305	L82J7G3750305	1
Saskatoon - Saskatchewan	L831	1401	1405	L82J7E3001307	L82J9E3001311	5
Saskatoon - Saskatchewan	L894	1501	1510	L82J0F3001490	L82J7F3001499	10
Saskatoon - Saskatchewan	L953	1601	1610	L82J9G3750158	L82JXG3750167	10
Saskatoon - Saskatchewan	LA29	1701	1711	L82J7H9775846	L82JXH9775856	11
Sault Ste. Marie Ontario	L934	—	—	L82JXG3750038	L82JXG3750038	1
SEPTA - Pennsylvania	L728	—	—	L82W7D4500335	L82W7D4500335	1
SEPTA - Pennsylvania	L741	7355	7355	S92L4E4500504	S92L4E4500504	1
SEPTA - Pennsylvania	L742	7371	7414	S92L6E4500729	S92L7E4500772	44
SEPTA - Pennsylvania	L743	7356	7370	S92L1E4500489	S92L2E4500503	15
SEPTA - Pennsylvania	L744	8601	8689	L82L7E4500570	L82LXE4500661	89
SEPTA - Pennsylvania	L745	7415	7415	S92L0F4500873	S92L0F4500873	1
SEPTA - Pennsylvania	L746	7416	7454	S92L7F4500952	S92L8F4501012	39
SEPTA - Pennsylvania	L749	7302	7354	S92Y7D4500409	S92L2E4500470	53
SEPTA - Pennsylvania	L861	7300	7484	S92L5G9775188	S92L8G9775220	32
St. Catharines Ontario	L879	1501	1504	L82J4F3001587	L82J4F3001590	4
St. Catharines Ontario	L882	1601	1605	L82J9G3750225	L82J9G3750229	5
St. John - New Brunswick	L871	40585	40586	L82J8F3001592	L82JXF3001593	2
St. John - New Brunswick	L939	40687	40687	L82J0G3750078	L82J0G3750078	1
St. John's - Newfoundland	L808	1415	1419	L82J4E3001152	L82J1E3001156	5
St. John's - Newfoundland	L875	1520	1525	L82JXF3001478	L82J3F3001483	6
St. John's - Newfoundland	L930	1626	1630	L82J7F3001826	L82J9F3001830	5
Stratford - Ontario	L893	—	—	L82J9F3001584	L82J0F3001585	2
Sudbury - Ontario	L890	851	855	L82JXF3001609	L82J6F3001641	5
Sudbury - Ontario	L994	861	865	L82J1G3750364	L82J9G3750368	5
Thunder Bay - Ontario	L806	—	—	L82J6E3001170	L82J8E3001171	2
Thunder Bay - Ontario	L863	—	—	L82J8F3001558	L82J6F3001560	3
Thunder Bay - Ontario	L944	—	—	L82J6G3750084	L82JXG3750086	3

CLIENT	ORDER	ROAD NUMBER		VIN (2NVY/4RKY...)		QTY
		FROM	TO	FROM	TO	
Thunder Bay - Ontario	LA01	—	—	L82J5H3750448	L82J7H3750449	2
Timmins - Ontario	L783	—	—	L82U8D3001017	L82UXD3001018	2
Timmins - Ontario	L839	—	—	L82J8E3001395	L82J8E3001395	1
Timmins - Ontario	L995	—	—	L82JXG3750377	L82JXG3750377	1
Toronto Transit Commission - TTC - Ontario	L859	8400	8400	L82J5F3001405	L82J5F3001405	1
Toronto Transit Commission - TTC - Ontario	L860	8401	8504	L82J0F3001554	L82JXF3001805	104
Toronto Transit Commission - TTC - Ontario	L937	8510	8617	L82J9G3750001	L82J3G3750401	108
Toronto Transit Commission - TTC - Ontario	L998	8620	8716	L82J3H3750545	L82J4H3750683	97
Toronto Transit Commission - TTC - Ontario	LA67	8720	8919	L82J4H9775996	L82J3H9776248	200
University of Alabama - Alabama	L787	7028	7029	L82J2E4500507	L82J4E4500508	2
University of Alabama - Alabama	L902	7030	7030	L82J2F4500993	L82J4F4500994	2
University of Alabama - Alabama	L961	7032	7033	L82J7G9775294	L82J9G9775295	2
University of Alabama - Alabama	LA02	7034	7037	L82J8G9775546	L82JXG9775550	4
Vancouver Airport Authority - YVR British Columbia	L856	705	706	L82LXH3750530	L82L1H3750531	2
Vancouver Airport Authority - YVR British Columbia	L912	173	178	L82L5F3001812	L82L4F3001817	6
Welland - Ontario	L991	—	—	L82J9G3750287	L82J9G3750287	1
Welland Ontario	L866	—	—	L82J9F3001648	L82J9F3001648	1
Welland Ontario	L933	—	—	L82J1G3750011	L82J1G3750011	1
Whitehorse - Yukon	L784	43	43	L82U9D3001057	L82U9D3001057	1
Whitehorse - Yukon	LA04	—	—	L82J2G3750390	L82J4G3750391	2
Windsor - Ontario	L886	570	577	L82J8F3001818	L82J5F3001825	8
Woodstock - Ontario	L778	—	—	L82U2D3001014	L82U2D3001014	1
Woodstock - Ontario	L832	—	—	L82J9E3001342	L82J9E3001342	1
Woodstock - Ontario	L923	15-16	15-16	L82J9F3001746	L82J9F3001746	1
Woodstock - Ontario	LA08	17-08	17-08	L82J3H3750514	L82J3H3750514	1
York Regional Transit - Ontario	L896	1501	1517	L82J2F3001619	L82JXF3001741	17
York Regional Transit - Ontario	L936	1518	1518	L82J3G3750012	L82J3G3750012	1
York Regional Transit - Ontario	L964	1770	1774	S92J6G3750420	S92J3G3750424	5
York Regional Transit - Ontario	L967	1601	1621	L82J2G9775414	L82J8G9775627	21
York Regional Transit - Ontario	LA07	1701	1715	L82J9G3750340	L82JXG3750363	15

**WARNING**

Follow your internal safety procedures.

Disconnect the batteries before starting any work on the vehicle. See the section 16: BATTERIES of the maintenance manual.

**NOTE**

Nova Bus has been advised by its engine supplier that the Cummins engine code 3568 might be sensitive to the variations in DEF level. An adjustment of the coolant hoses and the angle of the dosage module is necessary before considering the occurrence of the code 3568 as a defect.

PROCEDURE

- 1.1. Park the vehicle on an even surface with transmission in neutral (N).
- 1.2. Set the Master control switch in the STOP position (see Figure 1).

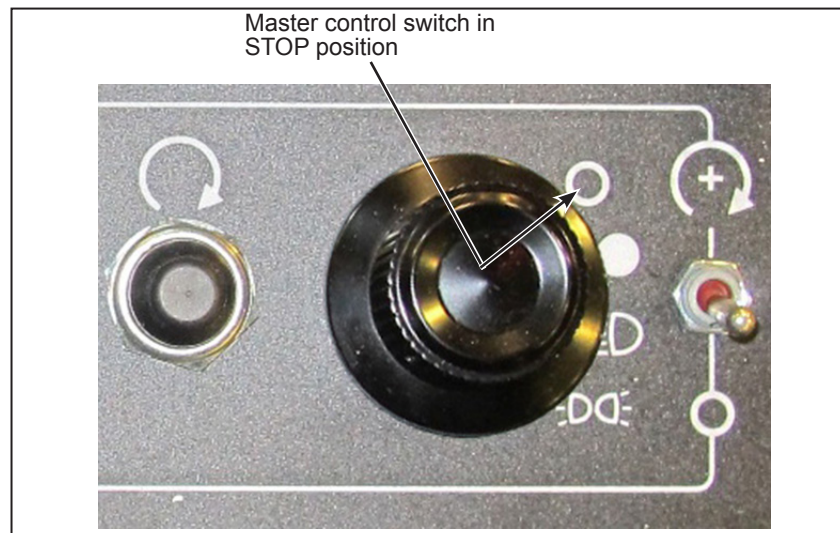


Figure 1 - Master Control Switch in STOP Position

**WARNING**

Before starting any work on the vehicle, make sure the vehicle is completely and securely stationary. Set the battery disconnect switch in the battery compartment to the OFF position.

- 1.3. Deactivate the bus from the rear engine control box (see Figure 2).

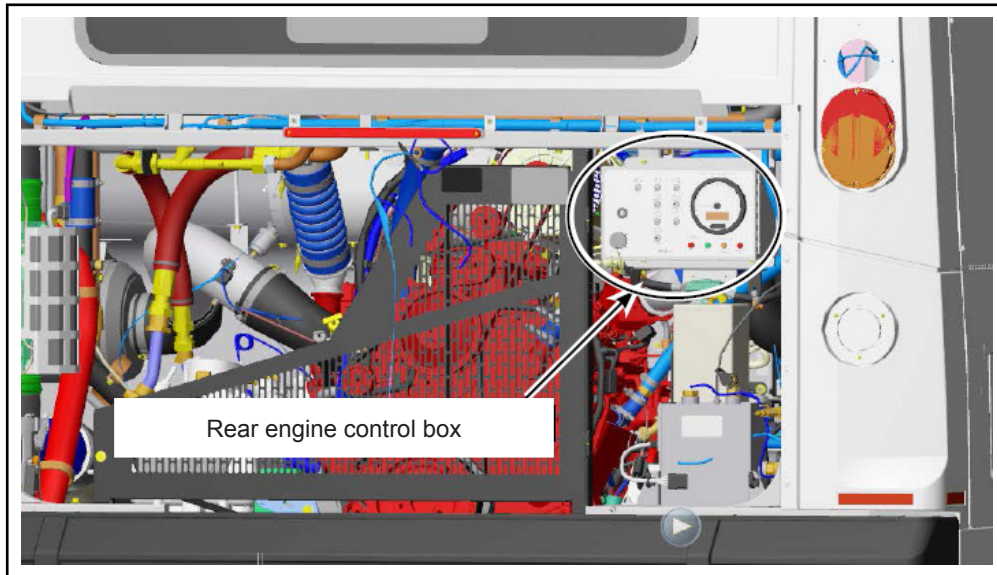


Figure 2 - Typical Location of Rear Engine Control Box

- 1.4. Open the street side rear engine access panel (can vary as per the configuration) (see Figure 3).

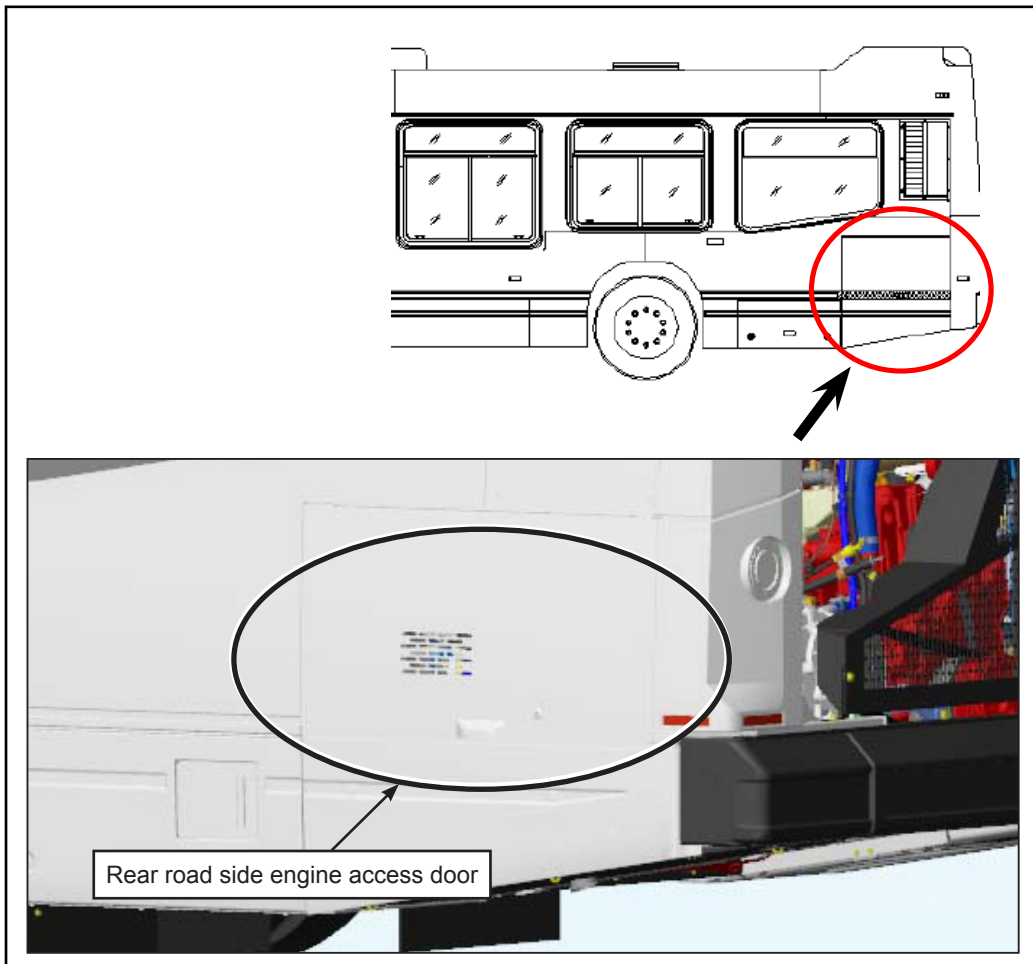


Figure 3 - Open the street side engine access panel

- 1.5. Verify that the angle of the dosage module is between 45° and 85° w.r.t. its vertical axis. The ideal angle is 54° (see Figure 4).

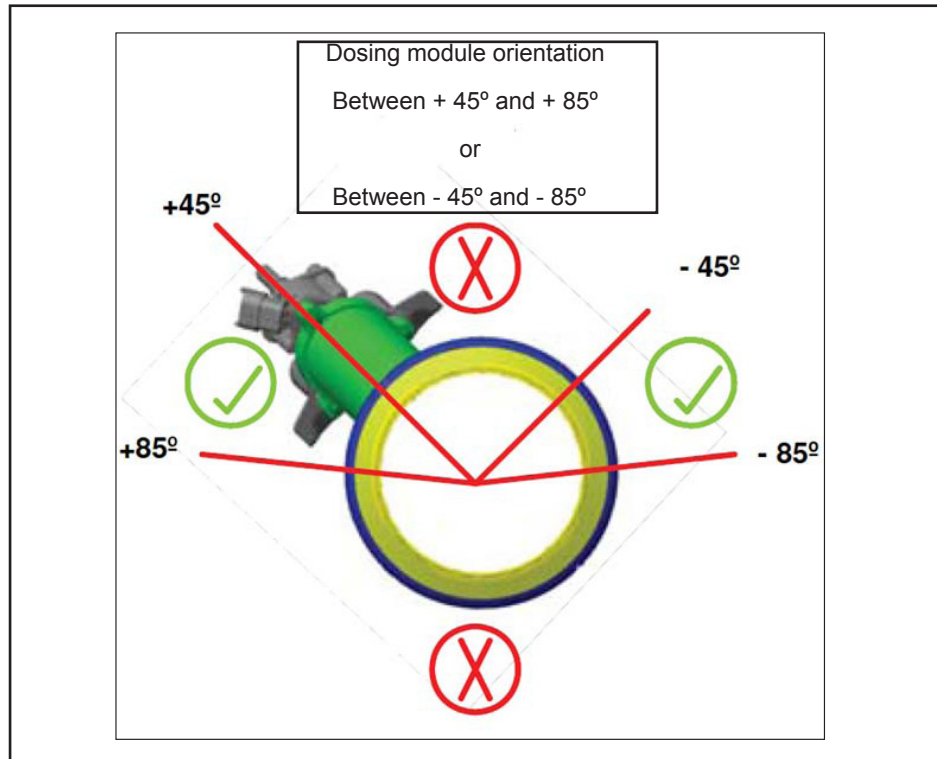


Figure 4 - Verify the angle of the dosage module

- 1.6. Adjust the dosage module angle using the jig NT08134 as shown (see Figure 5) to obtain an angle specified (see Figure 4).

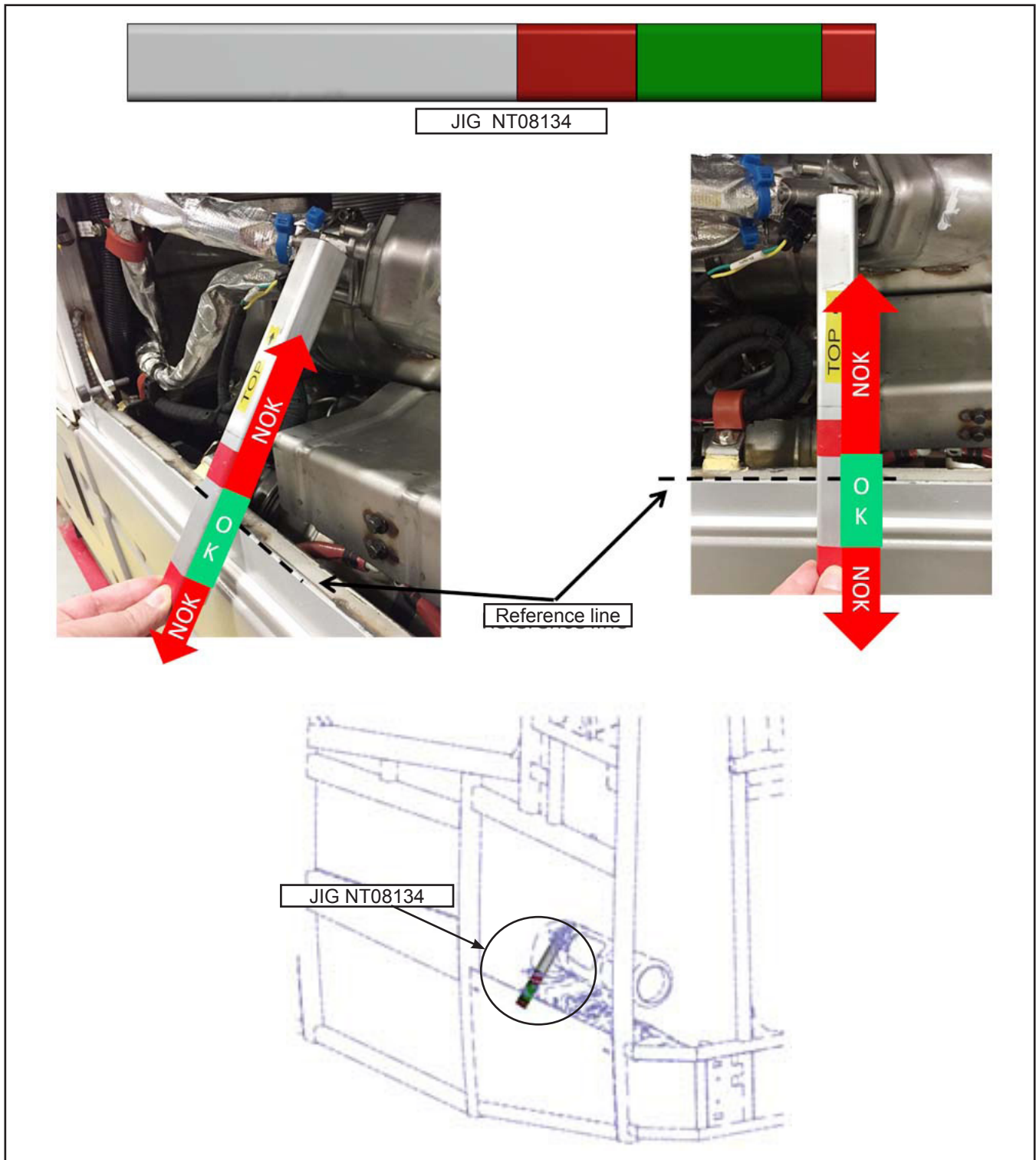


Figure 5 - Adjust the angle of the dosage module

- 1.7. If the dosage module angle requires adjustment, loose the clamp screws and turn the decomposition tube to obtain an angle of approximately 54° using the jig NT08134 (see Figure 6).

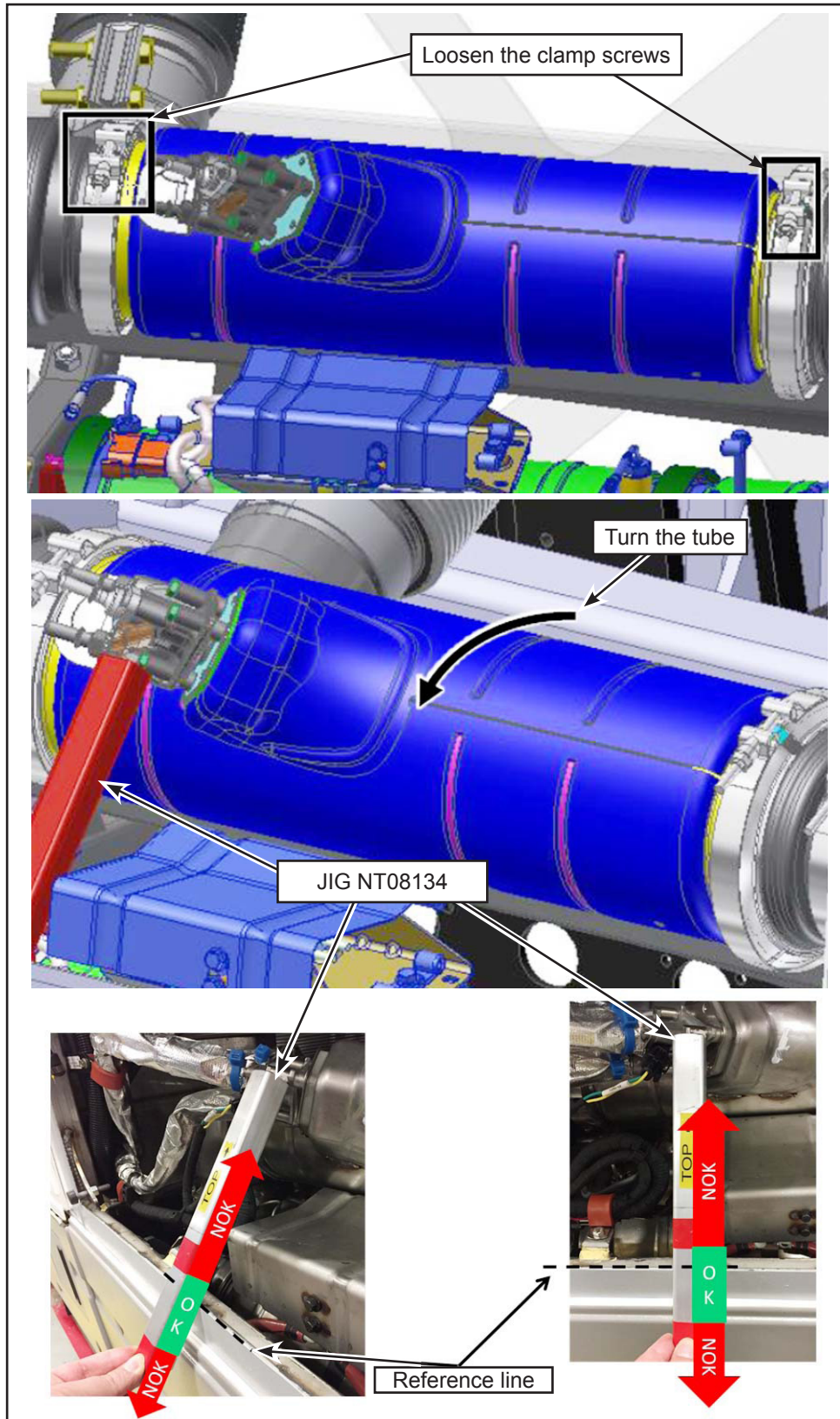


Figure 6 - Adjust the angle of the dosage module

- 1.8. Tighten the clamps by applying the torque value of 14 ± 1 N•m (see Figure 7).

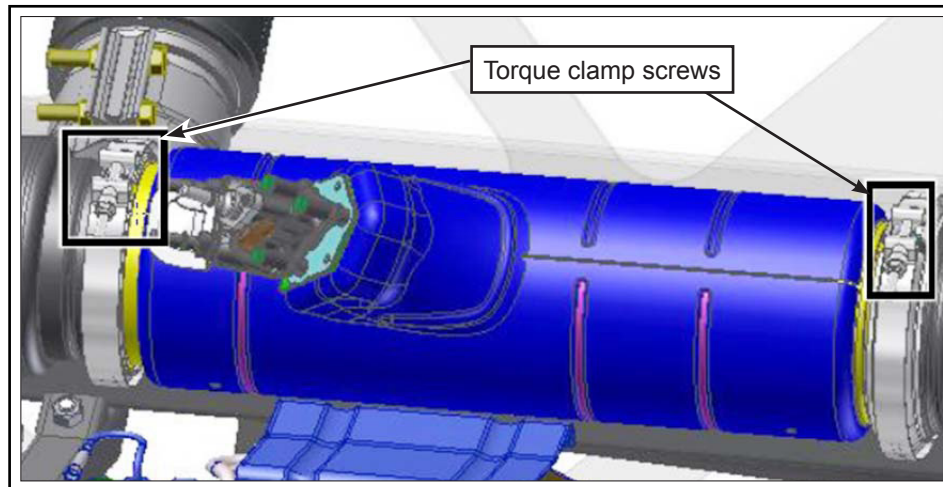


Figure 7 - Tighten the clamps

- 1.9. Locate the decomposition coolant lines (see Figure 8).
1.10. Locate all the positions (A, B, C, D and E) shown (see Figure 8), where new brackets have to be installed.

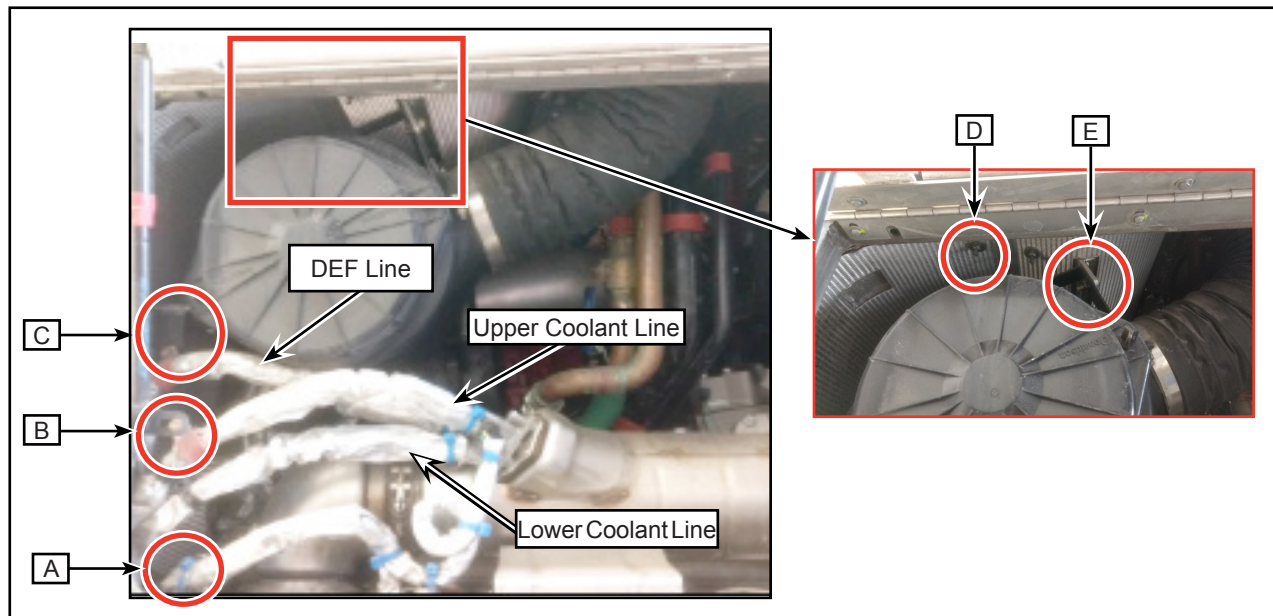


Figure 8 - Typical View of Coolant Lines

- 1.11. Drain the coolant circuit.

1.12. Remove and discard the tie wraps holding the electrical harness and lower coolant line (see Figure 9).

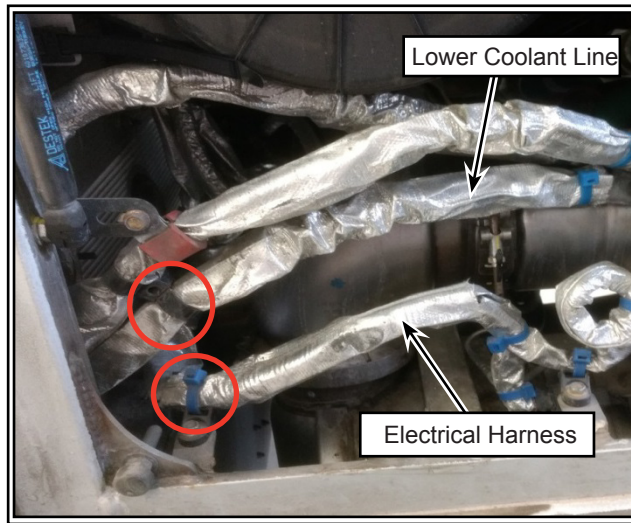


Figure 9 - Removal of Tie Wraps

1.13. Remove and retain the existing plastic bracket and hardware from its original position shown (see Figure 10).

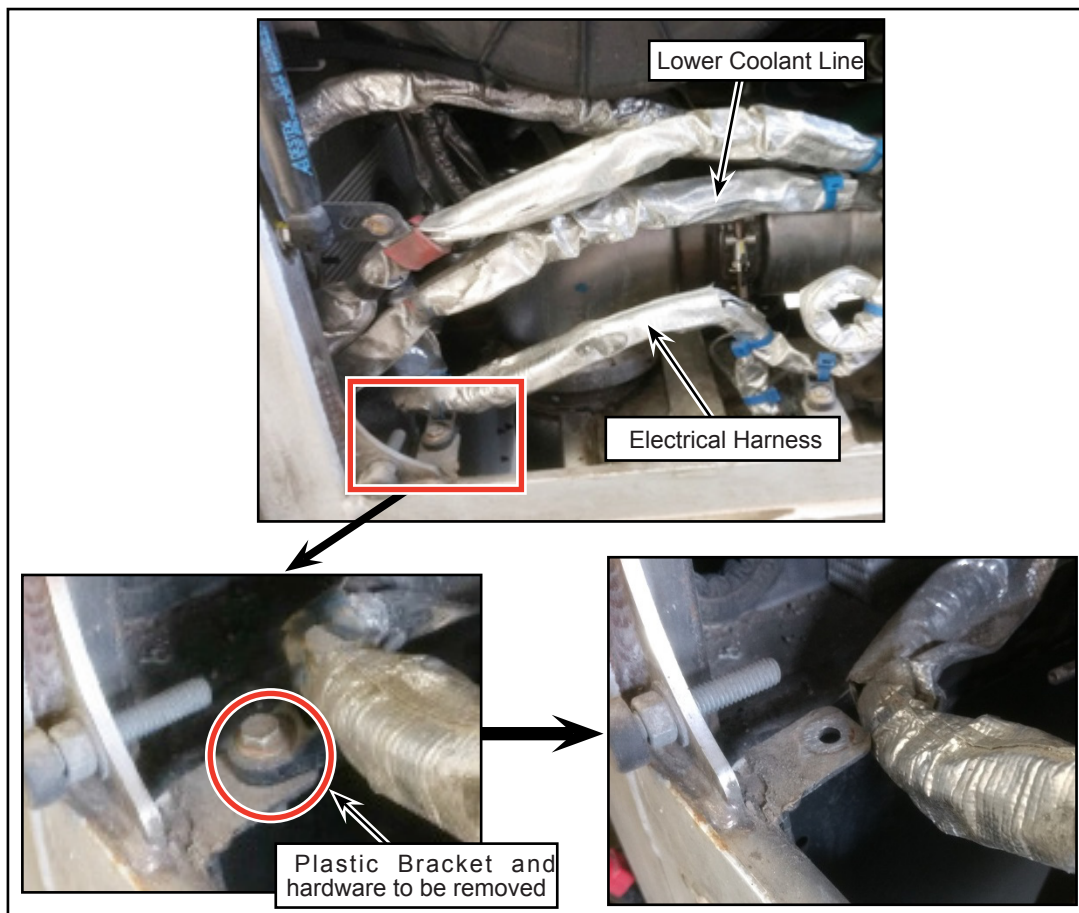


Figure 10 - Removal of Plastic Bracket and Hardware

- 1.14. Install the bracket (N87984) and the retained plastic bracket in the inverse position from its original position as shown (see Figure 11) with the hardware provided.

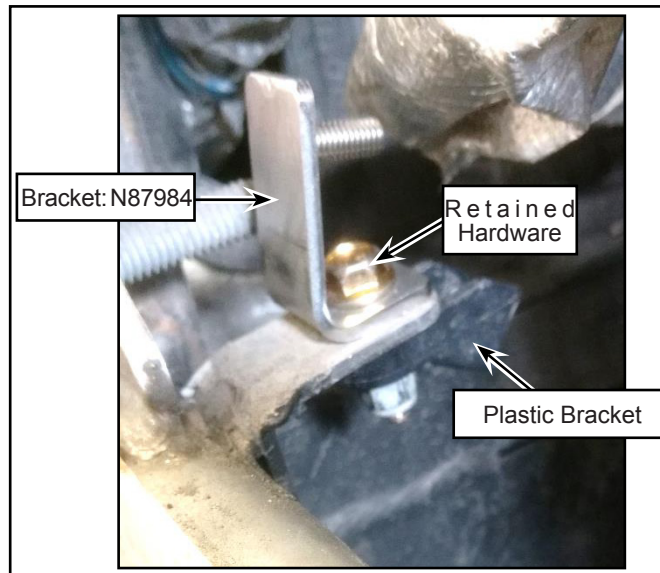


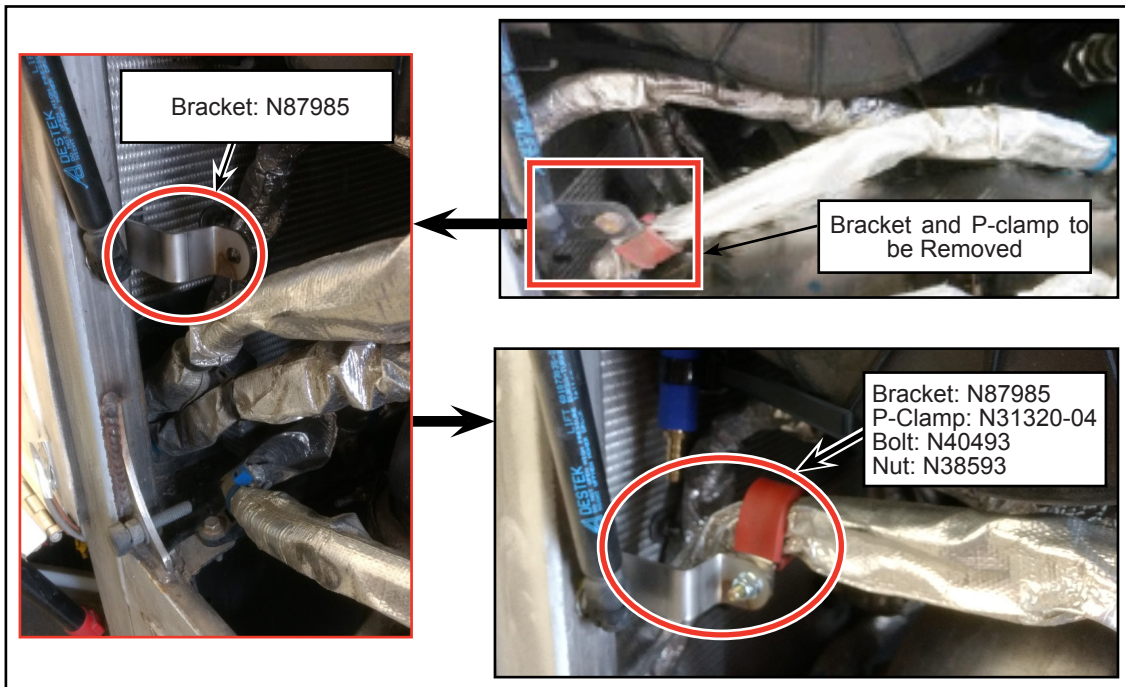
Figure 11 - Installation of New Bracket

- 1.15. Secure the electrical harness to plastic plug using tie wrap N56339.
- 1.16. Reposition the lower coolant line at the lowest point as shown (see Figure 12).
- 1.17. Install the p-clamp N31320-04 on the bracket to secure the lower coolant line (see Figure 12).

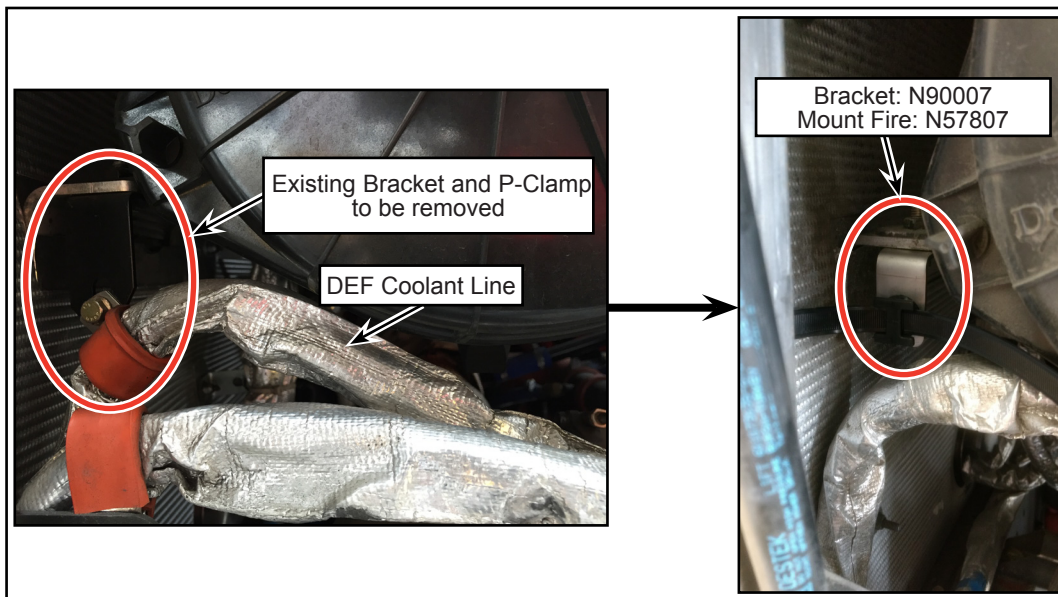


Figure 12 - Installation of P-Clamp and Tie Wrap

- 1.18. Remove the existing bracket and p-clamp securing the upper coolant line. Retain the bracket hardware.
- 1.19. Install the new bracket N87985 with the retained hardware (see Figure 13).
- 1.20. Install new p-clamp N31320-04 with the new bolt N40492 and nut N38593 provided to secure the upper coolant line as shown (see Figure 13).



- 1.21. Remove and discard the existing bracket and p-clamp holding the DEF coolant line at the location shown (see Figure 13). Retain the bracket hardware.
- 1.22. Install the new bracket N90007 with the retained hardware and fix the mount fire N57807 (see Figure 14).



- 1.23. Remove and discard the hardware at the location shown (see Figure 15).
- 1.24. Install the new bracket N90018 with new nut N38593 and fix the mount fire tree N57807 to bracket (see Figure 15).

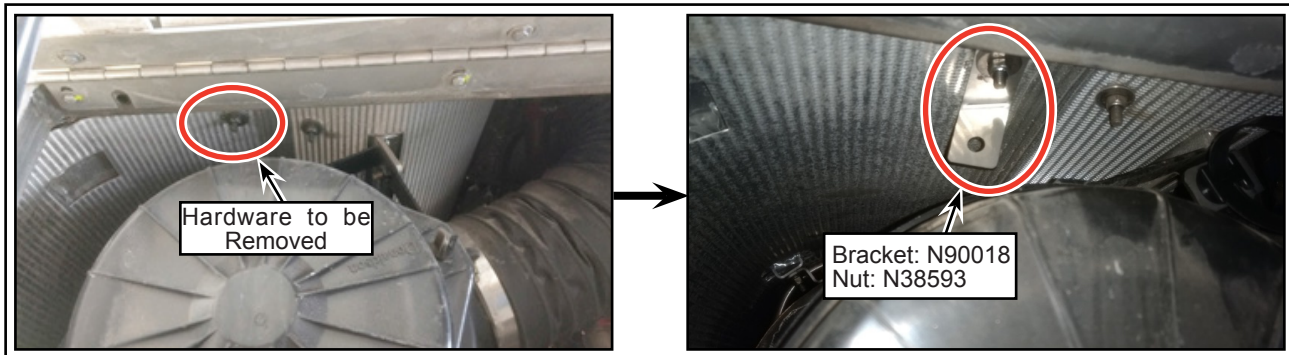


Figure 15 - Typical View of New Bracket Installed

- 1.25. Remove and retain the hardware at location shown (see Figure 16).
- 1.26. Install the new bracket N90007 with the retained hardware and fix the mount fire tree to bracket (see Figure 16).

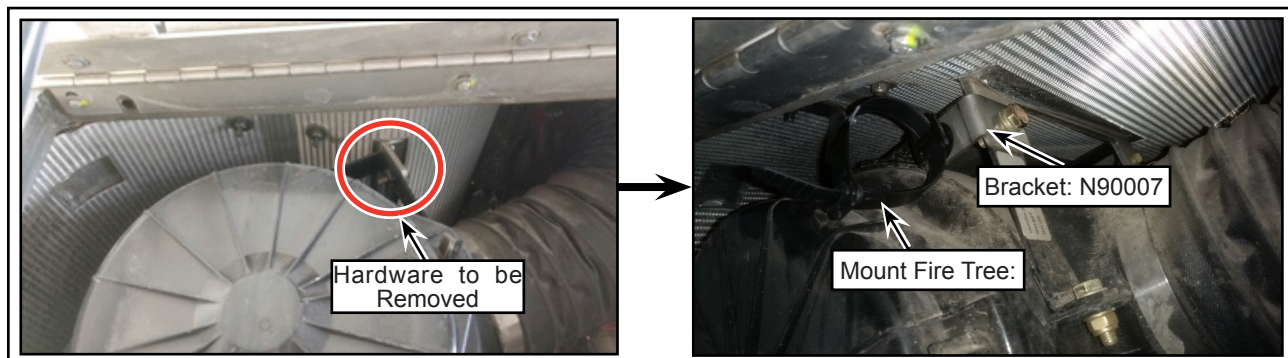


Figure 16 - Installation of New Bracket and Mount Fire

- 1.27. Cut the existing DEF coolant hose as shown and discard the other portion of hose connected to dosing module.
- 1.28. Insert one end of the fitting N75961 in new hose N95827-35 and other end in the retained cut hose (see Figure 17).
- 1.29. Install stepless crimp N57634-01 as shown (see Figure 17).

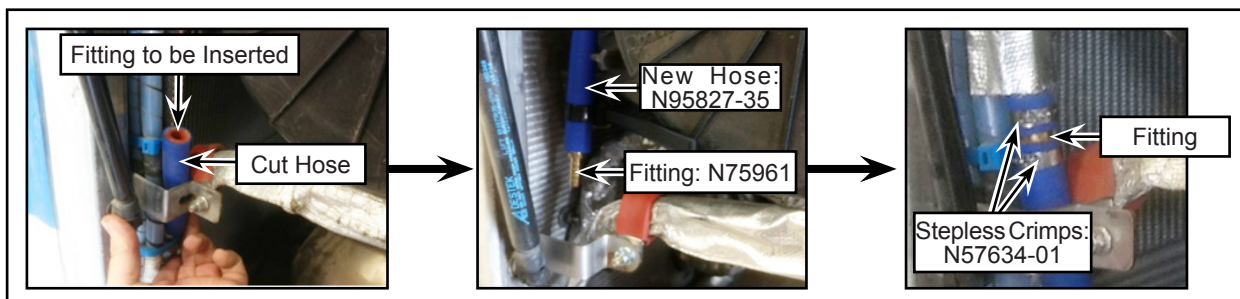


Figure 17 - Preparation of DEF Hose

- 1.30. Adjust the DEF hose length to fit the 90° quick connector at the dosing module.
- 1.31. Insert 90° quick connector N90005 in DEF hose and install stepless crimp as shown (see Figure 18).
- 1.32. Fix the 90° quick connector on the dosing module (see Figure 18).

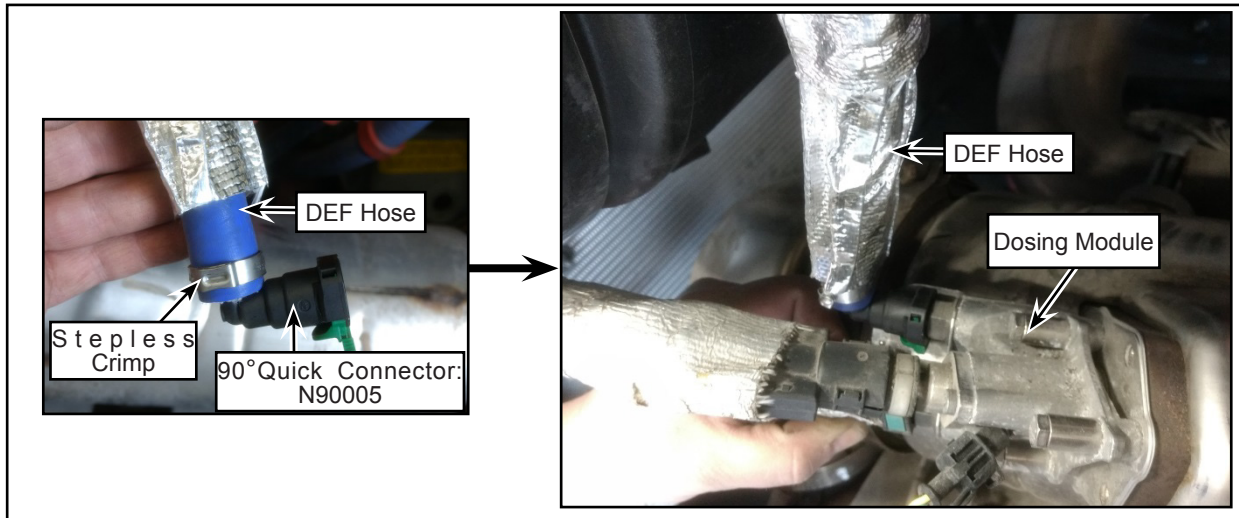


Figure 18 - Typical View of Quick Connector on Dosing Module

- 1.33. Install the reflective sleeve to cover the cut portion and 90° quick connector.
- 1.34. Secure the DEF hose with the mount fire tree fixed on the new brackets (see Figure 19).

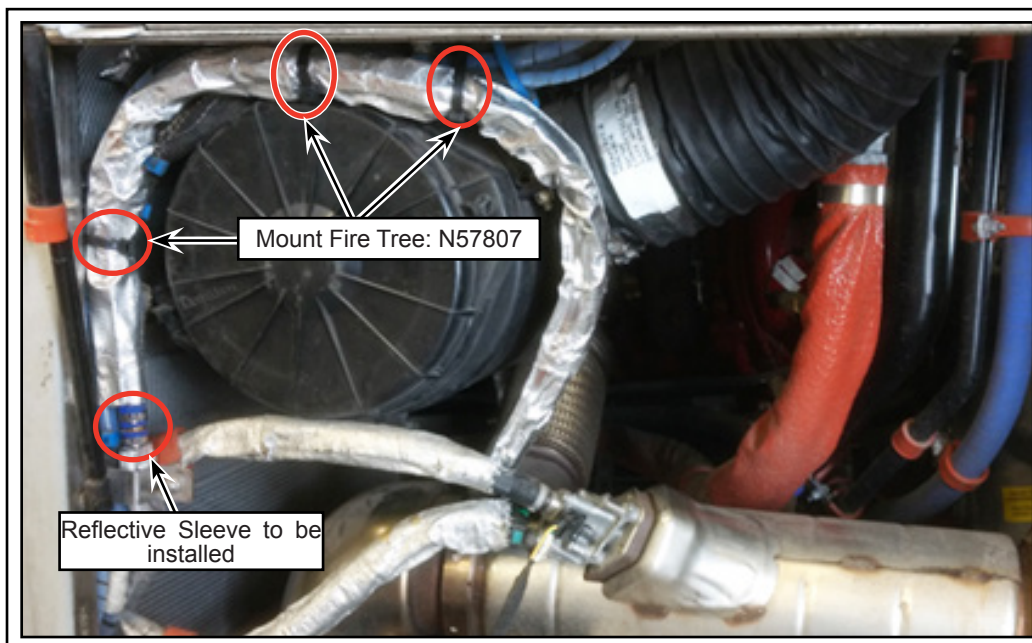


Figure 19 - Installation of Reflective Sleeve

1.35. Fill the coolant circuit.

**WARNING**

Connect the batteries after the repair is completed. See manual section 16: BATTERIES for the procedure.

- 1.36. Return the rear run switch to the normal operating position.
- 1.37. Run the bus for 15 minutes and check for any possible leaks.
- 1.38. Return the vehicle to service.❖