

Air-Conditioning Compressor

Vehicle Type: **911 Carrera (911)/911 Targa (911)/911 Speedster (911)**

Model Year: **As of 1984 up to 1989**

Concern: **Replacing air-conditioning compressor during repairs**

Notes: If a faulty air-conditioning compressor (⇒ *Figure 1*) for the 911 needs to be replaced, an air-conditioning compressor of similar design is available. The new air-conditioning compressor must **ONLY** be used with the new V-belt. **Please remember this when ordering parts!**

All connections and fastening points are the same as on the standard air-conditioning compressor. There is no need to change the high-pressure/low-pressure lines!

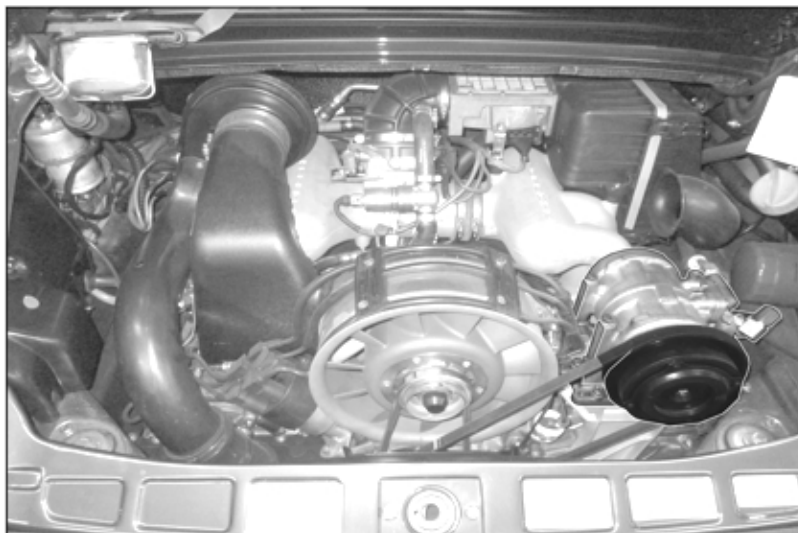

Figure 1

Parts Info: **930.126.021.07** 1 x ⇒ Air-conditioning compressor –complete–, set
999.192.247.50 1 x ⇒ V-belt

Parts List:

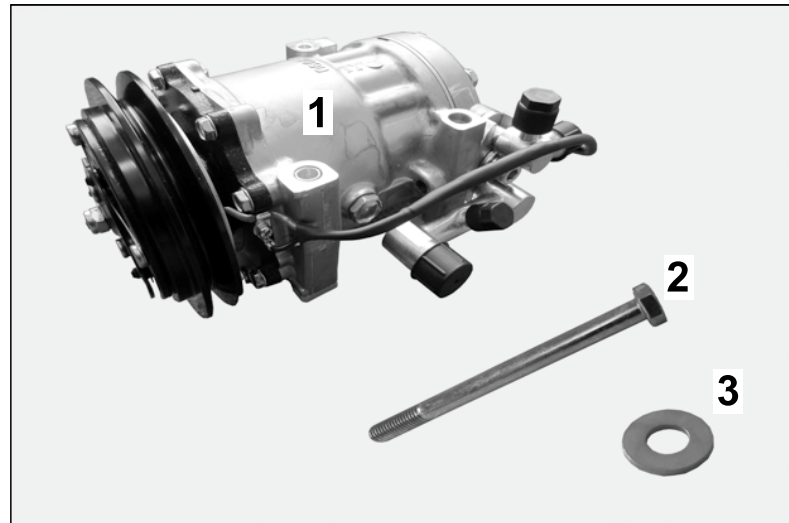

Figure 2

----	1 x	Air-conditioning compressor assembly (ASSY) incl. connections, filled with approx. 135 ccm of refrigerant oil (PAG 100) ⇒ <i>Figure 2</i>
		-1-
PCG.126.021.07	1 x	Assembly kit, comprising: 3 x Hexagon-head bolt, M8 x 110 – DIN 931 ⇒ <i>Figure 2</i> -2- 3 x Washer, 8.4 x 18 x 2 – DIN 134 ⇒ <i>Figure 2</i> -3-

Materials:	000.043.305.79	1 x	Refrigerant oil (as required)
	----	1 x	Refrigerant R134a, approx. 975 +/- 25 g

Tools:

- VAS 6746 - Air-conditioning service station** or
- VAS 6853 - Air-Conditioning service station**
- Rubber gloves (commercially available)
- Protective goggles (commercially available)
- Thermometer

⚠ WARNING

Refrigerant

- **Danger of freezing**
- ⇒ **Avoid contact with refrigerant.**
- ⇒ **Wear personal protective gear.**

- ⇒ Observe the safety regulations for working on air-conditioned vehicles and dealing with refrigerant.
- ⇒ Observe the safety regulations for extraction and filling systems.
- ⇒ Observe the instructions for repairing air conditioning systems and storing spare parts.

Work Procedure: 1 Preparatory work



Information

- On air-conditioning service equipment with a transparent oil separator, read and take note of the oil level before removing refrigerant.
- Do not carry out this step on empty air-conditioning systems (pressure gauge approx. 0 psi/bar) because if you do, air will get into the refrigerant bottle.
- If the vehicle is cold, it may be necessary to repeat the suction procedure until all refrigerant has been removed from the air-conditioning system. This step is carried out automatically with some units.

1.1 Drain refrigerant

- 1.1.1 Start the engine and switch on air conditioning. Leave the engine running for a short time.

To achieve maximum air conditioning performance: switch off fresh-air and warm air flow.



Information

- If the air-conditioning compressor is blocked or seized up, then additional steps must be carried out to ensure that the air-conditioning system is working. See section on **Work steps for blocked or seized up air-conditioning compressor**
- 1.1.2 Check that the air conditioning is working in order to determine whether additional maintenance and repair work (e.g. faulty lines, etc.) is required.

1.1.3 Unscrew protection cap (red/blue) from the valves (\Rightarrow Figure 3).

- 1 – High pressure: Protection cap –red–
- 2 – Low pressure: Protection cap –blue–
- 3 – Air-conditioning compressor



Information

- Before connecting high-pressure and low-pressure lines to the vehicle, remove any refrigerant in the lines by suction.
- Be careful of the sealing rings when disconnecting or connecting the hose connections!

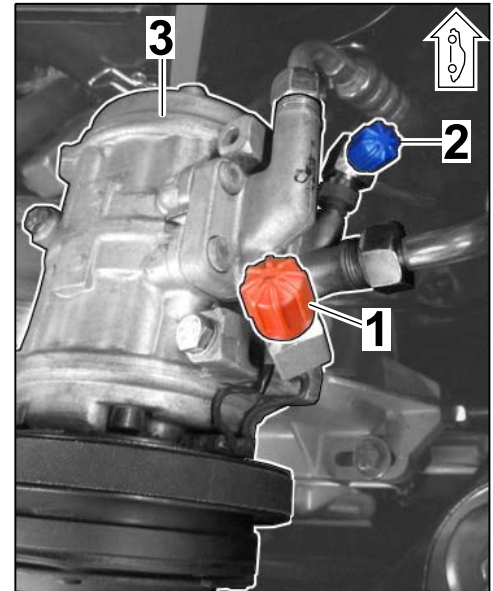

Figure 3

1.1.4 Connect high-pressure line and low-pressure line from the air-conditioning service station to the respective valve.

1.1.5 Remove refrigerant by suction.

Drain the removed quantity using the servicing equipment if necessary and measure it.

1.1.6 Extract and measure refrigerant oil (V_{removed}).

If not enough refrigerant oil was removed or separated, proceed as follows depending on the type of air-conditioning compressor:

- Air-conditioning compressor **WITH** oil drain plug: Drain refrigerant oil via the oil drain plug and measure it (V_{old}).
- Air-conditioning compressor **WITHOUT** oil drain plug: Continue with the next step

1.2 Removing air conditioning compressor

1.2.1 Unscrew hose connections. Close off connections and lines using stoppers (⇒ Figure 4).

- 1 - Low-pressure connection
- 2 - High-pressure connection

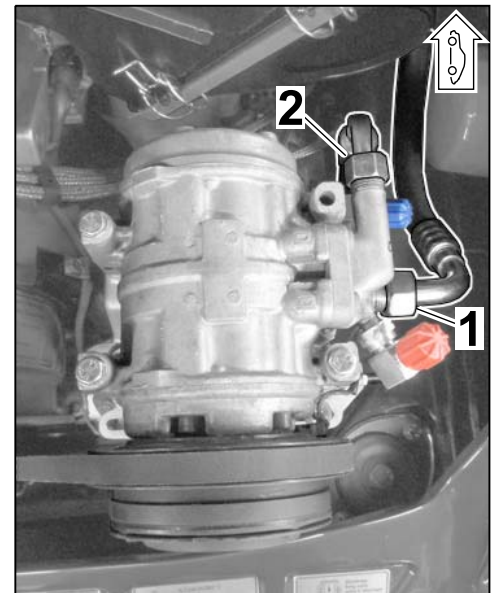

Figure 4

1.2.2 Disconnect electric plug connection for the air-conditioning compressor (⇒ Figure 5).

- 1 - Electric plug connection
- 2 - Hexagon-head bolt, M8 x 35
- 3 - Hexagon nut M8
- 4 - Air-conditioning compressor plate
- 5 - Lock nut
- 6 - Tension screw

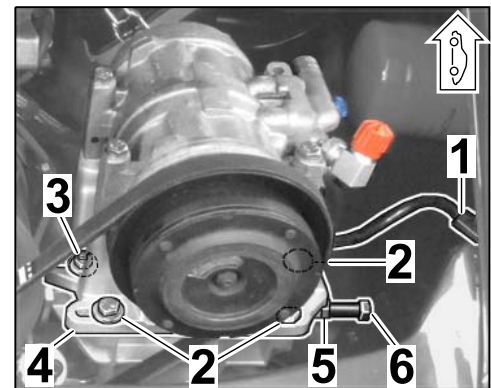

Figure 5

1.2.3 Loosen three hexagon-head bolts (M8 x 35) and one M8 hexagon nut on the stud on the air-conditioning compressor plate (⇒ Figure 5).

1.2.4 Then **LOOSEN** lock nut (1 x) on the tension screw on the air-conditioning compressor plate and unscrew tension screw (⇒ Figure 5).

- 1.2.5 Push air-conditioning compressor plate with air-conditioning compressor as far as possible to the left and take the V-belt down off the pulley (⇒ *Figure 6*).

- 1 – Air-conditioning compressor plate
- 2 – Hexagon-head bolt, M8 x 110
- 3 – Air-conditioning compressor

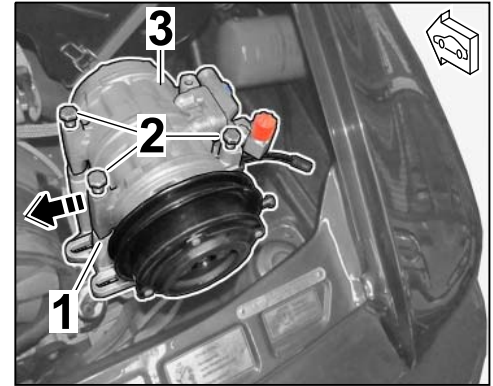

Figure 6

- 1.2.6 Remove hexagon-head bolt (3 x) on the compressor (⇒ *Figure 6*).
- 1.2.7 Take air-conditioning compressor down off the air-conditioning compressor plate.



Information

All connection points must be completely dirt-free.

The air-conditioning compressor must be dry (washing the vehicle) and the air-conditioning compressor and lines must be free of moisture.

The connection points must be closed after they have been opened. Use the original transport caps.

A clean measuring cylinder with a capacity of approx. 300 ml is required.

2 Work steps for blocked/seized up air-conditioning compressor

- 2.1 Remove desiccator.
- 2.2 Check connections on the condenser, on the desiccator and at the refrigerant lines for the desiccator for signs of wear/chips.

Is there wear/chips?

- **YES:** Continue with 2.2.1
- **NO:** Continue with 2.3

- 2.2.1 Remove refrigerant line between compressor and condenser.
- 2.2.2 Flush refrigerant line between the compressor and condenser using a suction and pressure syringe and commercially available acetone. The acetone dissolves the refrigerant oil in the air-conditioning line.
- 2.2.3 Allow the acetone to dry off in the refrigerant line.
- 2.2.4 Wrap bright fabric around the refrigerant line connection between the compressor and condenser and secure it on the line with a tie-wrap.

⚠ WARNING

Working with compressed air

- Risk of eye injuries
- Risk of damaging and dirtying components
- ⇒ Wear protective goggles with side eye protection.
- ⇒ Protect the point at which the compressed air emerges with suitable material.
- ⇒ Place the point at which the compressed air emerges on suitable surfaces.

2.2.5 Blow out refrigerant line between the compressor and condenser using pure compressed air (with **NO** oil or water mixed in).

2.2.6 Replace condenser and desiccator.

2.2.7 Install refrigerant line between the compressor and condenser.

2.3 Replace desiccator.

NOTICE

Too much or too little refrigerant oil in air conditioning circuit

- Reduced cooling output
- Lack of lubrication and failure of the air conditioning compressor
- ⇒ If a new air conditioning compressor or a component in the circuit is replaced, the oil quantity must be checked and adjusted.

3 Check and measure the refrigerant oil level in the air-conditioning compressor/cooling system

3.1 **ONLY** for air-conditioning compressor **WITHOUT** oil drain plug:
Measure refrigerant oil quantity of "old" air-conditioning compressor.

3.1.1 Open the oil filler screw on the air-conditioning compressor.

3.1.2 Fill refrigerant oil from the air-conditioning compressor into a measuring cylinder. Turn the pressure plate on the air-conditioning compressor (not the pulley) when emptying refrigerant oil.

3.1.3 Take note of the measured refrigerant oil quantity (V_{old}).

3.2 Check the refrigerant oil quantity of the total system ($V_{total} = 170 \text{ cm}^3$) and add refrigerant oil if necessary.

3.2.1 Calculate the refrigerant oil quantity of the total system (air conditioning) = V_{total} using the following formula:

$$V_{total} = V_{compressor\ new} + (V_{removed} + V_{old}) + V_{safety}$$

- $V_{\text{total}} = \text{Filling capacity } 170 \text{ cm}^3$
- $V_{\text{safety}} = \text{Filling capacity } 20 \text{ cm}^3$

Sample calculation:

$$V_{\text{total}} (170 \text{ cm}^3) = V_{\text{compressor new}} (135 \text{ cm}^3) + V_{\text{removed}}(X1) + V_{\text{old}}(X2) + V_{\text{safety}}(20 \text{ cm}^3)$$

3.3 Fill the air-conditioning compressor



Information

- New air-conditioning compressors are pressurised and filled with the total oil quantity required for the refrigerant circuit!
- The remaining oil quantity in the individual components must therefore be cleaned out!
- Refrigerant oil from the compressor or refrigerant oil removed by suction from a previously run air-conditioning system may no longer be used (special-category waste)!

4 Install new air-conditioning compressor.

4.1 Fit new air-conditioning compressor on the air-conditioning compressor plate and align it.

4.2 Screw on air-conditioning compressor securely using three new hexagon-head bolts (M8 x 110) and three washers (8.4 x 18 x 2).

Hexagon-head bolt, M8 x 110: **Tightening torque 22 Nm (16 ftlb.) +/- 2 Nm (+/- 1.5 ftlb.)**

4.3 Fit new V-belt on pulley and push air-conditioning compressor as far as possible to the right.

4.4 Tension V-belt using the tension screw and tighten lock nut on air-conditioning compressor plate.

4.5 Tighten three hexagon-head bolts (M8 x 35) and one M8 hexagon nut on the air-conditioning compressor plate.

Hexagon-head bolt, M8 x 35/hexagon nut, M8: **Tightening torque 22 Nm (16 ftlb.) +/- 2 Nm (+/- 1.5 ftlb.)**

4.6 Screw hose connections onto the air-conditioning compressor.

Suction connection (thread: 7/8 inch x 14 UNF): **Tightening torque 33 Nm (24 ftlb.) +/- 4 Nm (+/- 3 ftlb.)**

Pressure connection (thread: 3/4 inch x 16 UNF): **Tightening torque 24 Nm (18 ftlb.) +/- 4 Nm (+/- 3 ftlb.)**

4.7 Connect electric plug connection for the air-conditioning compressor.

5 Fill air conditioning system and perform function test

5.1 Connect high-pressure line and low-pressure line from the air-conditioning service station to the respective valve.

5.2 Fill in refrigerant oil

5.2.1 **ONLY** for equipment **WITH** integrated oil filling system:

- Enter the measured refrigerant oil quantity.
- Allow the equipment to take in the refrigerant oil.

5.2.2 **ONLY** for equipment **WITHOUT** integrated oil filling system:

- Start the vacuum pump
- At the start of the vacuum phase, add the measured quantity of refrigerant oil using an oil injector or a hose disconnected from the servicing equipment.
- Re-connect the hose to the servicing equipment immediately after adding the oil.

5.3 Evacuate the air-conditioning system

5.3.1 Evacuate the air-conditioning system for at least 20 minutes.

5.3.2 If the air-conditioning system was open for a long time, evacuate the system for up to 120 minutes.

NOTICE

Excessively high pressure in refrigerant circuit

- **Risk of damage to air-conditioning compressor**

⇒ **Do not allow the low-pressure gauge to exceed Nominal value 3 bar at any time.**

5.4 Fill the air-conditioning system

5.4.1 Using the servicing equipment, add the refrigerant quantity stated in the manual into the air-conditioning lines.

Refrigerant quantity: **Filling capacity 975 g +/-25 g**

5.4.2 Start the engine and carry out a leak test.

5.4.3 Check the performance of the new air-conditioning compressor (⇒ Figure 7).

- 1 – Low-pressure display
 - 2 – High-pressure display
- Low pressure at an engine speed of approx. 950 – 2,000 rpm = approx. 14.5 – 29 psi (1.0 – 2.0 bar)
 - High pressure at an engine speed of approx. 950 – 2,000 rpm = approx. 174–290 psi (12.0 – 20.0 bar)

To reach the high pressure values, switch off/disconnect the condenser blower if necessary.

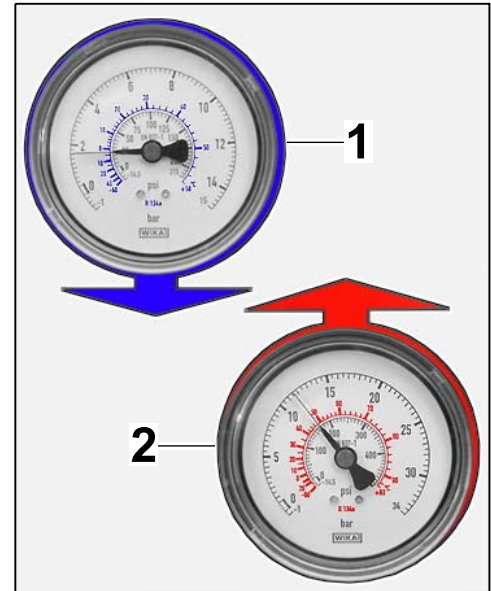

Figure 7

5.4.4 Temperature measurement on dashboard

- Temperature difference in the center vent area (dashboard) after approx. 20 minutes = approx. 41° F (5° C)

6 Concluding work

- 6.1 Disconnect high-pressure line and low-pressure line from the air-conditioning service station.
- 6.2 Screw protection caps (black) onto the respective valve.

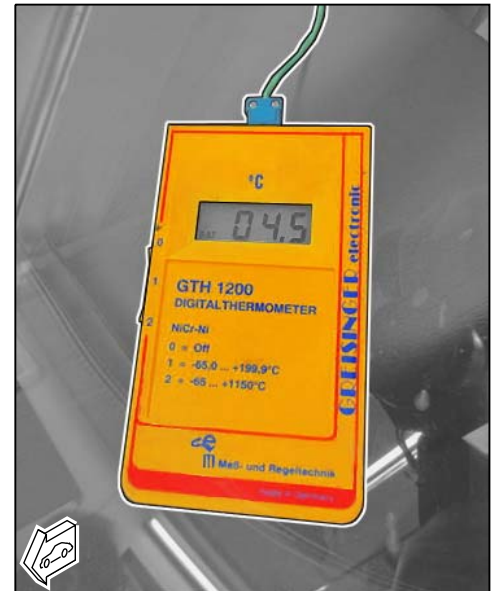

Figure 8

- 87 03 17 00: –Refrigerant drained and filled– Labor time: **130 TU**
Includes: Checking leak-tightness using leak tester.
 Checking cooling output of air-conditioning system.
Without: Draining and filling refrigerant. Separate LO no.!
- 87 34 19 00: –Compressor removed and installed– Labor time: **50 TU**
Includes: Loosening and securing refrigerant hoses.
Without: Draining and filling refrigerant. Separate LO no.!

Important Notice: Technical Bulletins issued by Porsche Cars North America, Inc. are intended only for use by professional automotive technicians who have attended Porsche service training courses. They are written to inform those technicians of conditions that may occur on some Porsche vehicles, or to provide information that could assist in the proper servicing of a vehicle. Porsche special tools may be necessary in order to perform certain operations identified in these bulletins. Use of tools and procedures other than those Porsche recommends in these bulletins may be detrimental to the safe operation of your vehicle, and may endanger the people working on it. Properly trained Porsche technicians have the equipment, tools, safety instructions, and know-how to do the job properly and safely. If a particular condition is described, do not assume that the bulletin applies to your vehicle, or that your vehicle will have that condition. See your authorized Porsche Dealer for the latest information about whether a particular technical bulletin applies to your vehicle. Part numbers listed in these bulletins are for reference only. Always check with your authorized Porsche dealer to verify the current and correct part numbers. The work procedures updated electronically in the Porsche PIWIS diagnostic and testing device take precedence and, in the event of a discrepancy, the work procedures in the PIWIS Tester are the ones that must be followed.

© 2018 Porsche Cars North America, Inc.