



Service Bulletin

File in Section: -

Bulletin No.: 16-NA-168

Date: May, 2016

INFORMATION

Subject: Service Tip for Installing #4 Cross Bar Protective Caps When Replacing Fuel Tank

Brand:	Model:	Model Year:		VIN:		Engine:	Transmission:
		from	to	from	to		
Chevrolet	Volt	2016	2017				

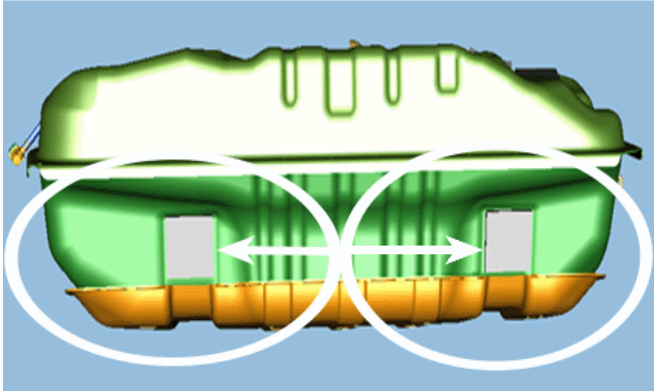
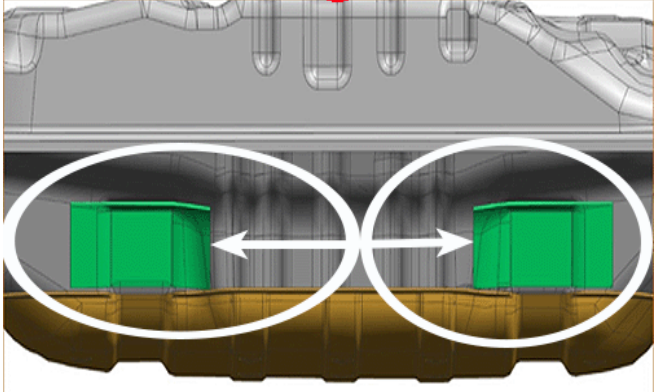
Involved Region or Country	North America and Korea
Condition	<div style="text-align: center; margin-bottom: 20px;"> ①  </div> <div style="text-align: center;"> ②  </div>
	4515969

When servicing the fuel tank and/or replacing the isolator pads, the padding on the new design tank (1) is smaller than the current design (2) and requires the protective caps be installed to the #4 cross bar.

Note: The pads on the new design fuel tank are 62 mm wide, 62 mm tall and 8 mm thick.

Note: When replacing the #4 cross bar, inspect the padding on fuel tank to see which design tank is on the vehicle. If the vehicle has the current design (2) fuel tank, **NO** protective caps need to be installed. If the vehicle has the new design fuel tank (1), protective caps need to be installed to the #4 cross bar.

Correction

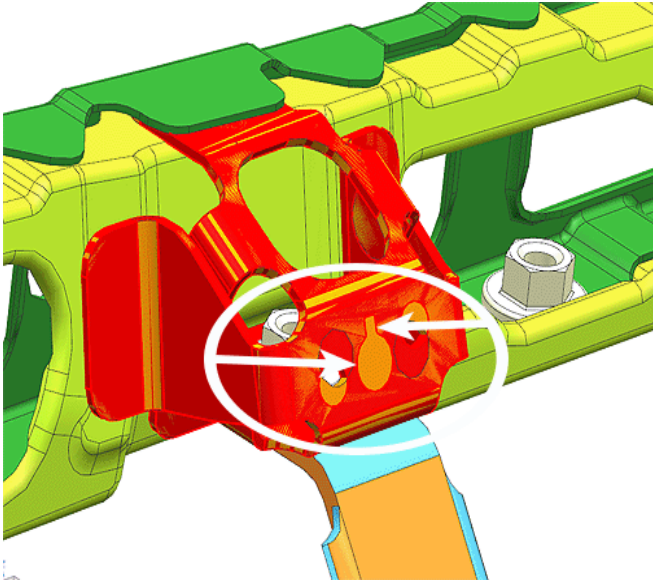

4510324

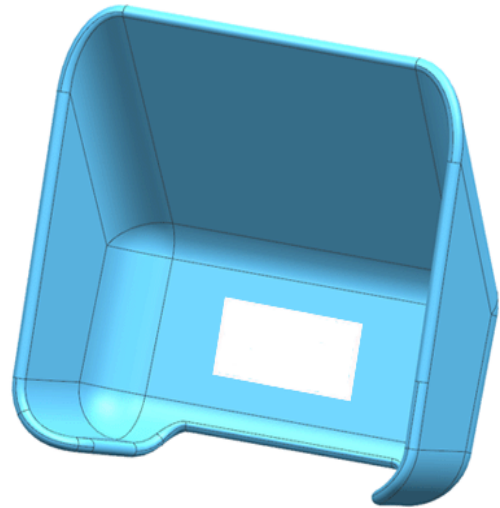

4510348

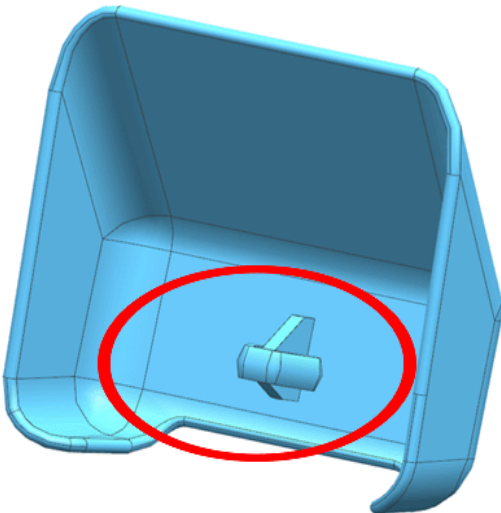

4509886

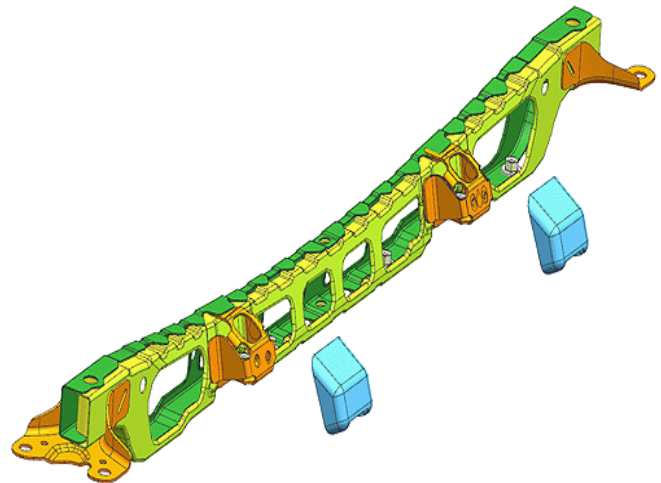

4510536

Before installing the caps, inspect the bracket on the #4 end cross bar for the HV battery for a key shaped hole. If the bracket doesn't come with the key shaped hole, grind off attaching feature on the back of the caps and retain them using double-sided tape.

Parts Information

Description	Part Number	Qty
CAP - BRACKET F/TNK	23374928	2

Version	1
Modified	

