

January 21, 2017

05612 Version 4

## High Pressure Fuel Pump Chirps

(Supersedes 16-008, dated October 4, 2016, to revise the information highlighted in yellow)

### AFFECTED VEHICLES

Year	Model	Trim	VIN range
2014–17	MDX	ALL	ALL
2015–17	TLX	ALL with V6	ALL
2014–17	RLX	ALL	ALL
2014 and 2016–17	RLX Hybrid	ALL	ALL

### REVISION SUMMARY

Under AFFECTED VEHICLES, the model year 2017 was added to RLX Hybrid. Under PARTS INFORMATION the Fuel Joint Pipe Set part number has changed.

### SYMPTOM

The high pressure fuel pump area chirps after the engine is warm.

### POSSIBLE CAUSES

The high pressure fuel pump is making a chirp.

NOTE: This noise does not impact pump, or engine function, or reliability.

### CORRECTIVE ACTION

Replace the high pressure fuel pump.

### PARTS INFORMATION

Part Name	Part Number	Quantity
Fuel Joint Pipe Set	16012-R9P-315	1
High Pressure Fuel Pump	16790-5J6-305	1
Retainer	17711-S0X-931	1
Intake Manifold Gasket (top)	17112-5G0-A01	1
Intake Manifold Gasket	17105-R9P-A01	1
Intake Manifold Base Gasket (RR)	17065-R9P-A01	1
Intake Manifold Base Gasket (FR)	17055-R9P-A01	1

**CLIENT INFORMATION:** The information in this bulletin is intended for use only by skilled technicians who have the proper tools, equipment, and training to correctly and safely maintain your vehicle. These procedures should not be attempted by "do-it-yourselfers," and you should not assume this bulletin applies to your vehicle, or that your vehicle has the condition described. To determine whether this information applies, contact an authorized Acura automobile dealer.

## WARRANTY CLAIM INFORMATION

The normal warranty applies.

Operation Number	Description	Flat Rate Time	Defect Code	Symptom Code	Template ID	Failed Part Number
1211U6	Replace the high pressure fuel pump (MDX).	1.8 hrs	03214	04201	16-008N	16790-5J6-305
1211FG	Replace the high pressure fuel pump (TLX).	1.9 hrs	03214	04201	16-008P	16790-5J6-305
1211U6	Replace the high pressure fuel pump (RLX).	1.7 hrs	03214	04201	16-008Q	16790-5J6-305
1211U6	Replace the high pressure fuel pump (RLX Hybrid).	1.7 hrs	03214	04201	16-008R	16790-5J6-305

Skill Level: Repair Technician

## DIAGNOSIS

1. With the hood open, listen for a chirping with the engine warmed up.
  - If the noise is coming from the high pressure fuel pump, go to REPAIR PROCEDURE.
  - If the noise is coming from the timing belt area, refer to service bulletin *14-025, Timing Belt Chirps*.
  - If the noise is not coming from the high pressure fuel pump or timing belt, continue with normal troubleshooting.

## REPAIR PROCEDURE

1. Relieve the fuel pressure.
2. Set the No. 1 piston at top dead center (TDC).
3. Remove the intake manifold and intake manifold base. See service information.

Note: Removal of the throttle body from the intake manifold is not required. Seal the two water hoses and leave it attached to the intake manifold

4. Remove the high pressure fuel pump cover.

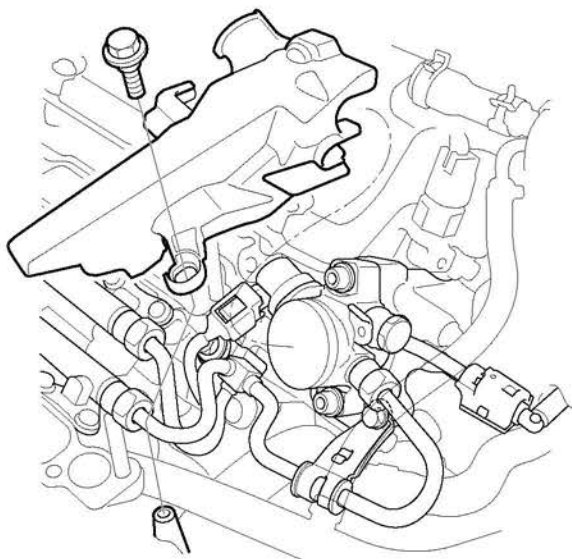

5. Remove the quick-connect fitting cover.

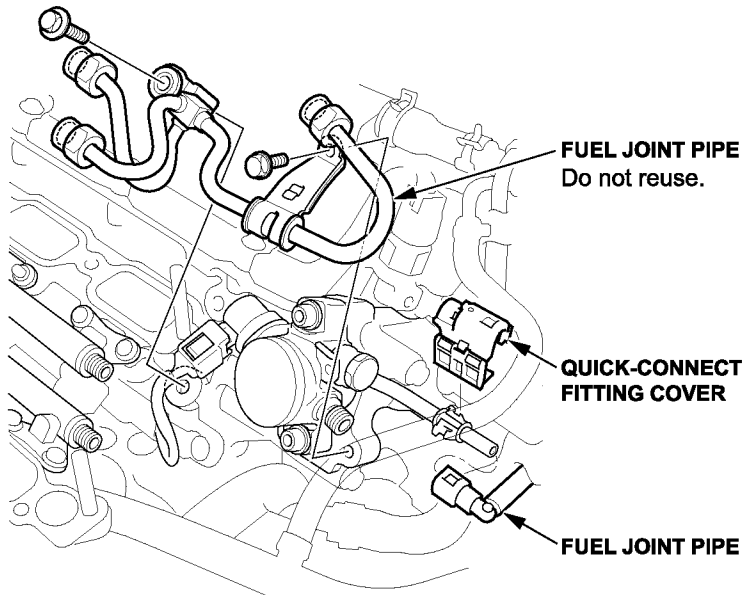

6. Disconnect the quick-connect fitting.
7. Remove the fuel joint pipe.
8. Disconnect the high pressure fuel pump connector.

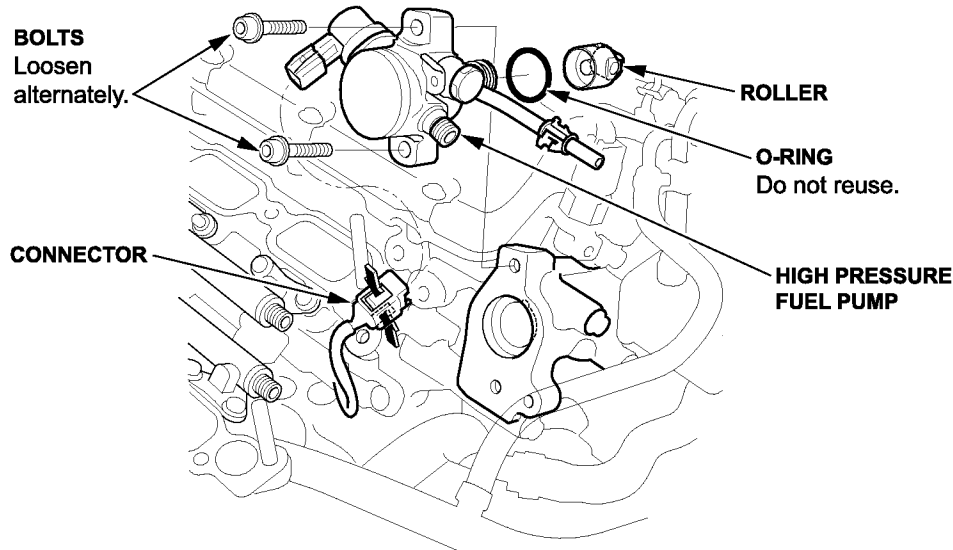

9. Remove the bolts by loosening them alternately, then remove the high pressure fuel pump and the roller.

10. Rotate the crankshaft and check the high pressure fuel pump cam for pits, scores, and excessive wear. If needed, replace the rear camshaft.

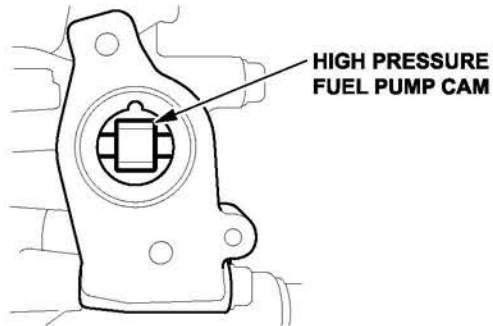

11. Set the No. 1 piston at top dead center (TDC).
12. Install the roller onto the high pressure fuel pump cam.

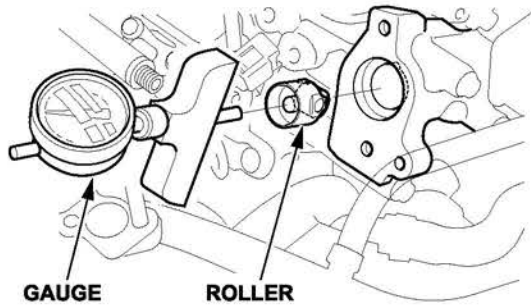

13. Set the gauge on the roller and hold it, then set the dial to zero.
14. Rotate the crankshaft 720° and measure the three cam lobes height. If the cam lobes are excessively worn, replace the rear camshaft.

NOTE: The high pressure fuel pump cam has three cam lobes. Cam Lobe Height Standard (New): 0.236 in (6.0 mm)

15. Set the No. 1 piston at top dead center (TDC).
16. Check the position of the cam that drives the high pressure fuel pump as shown.

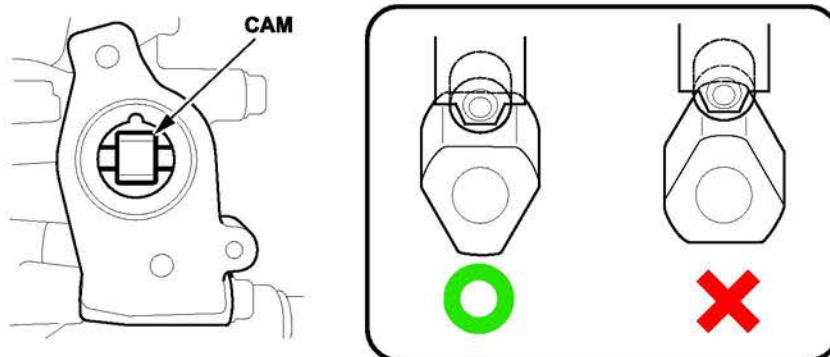

17. Coat the roller and the cam with clean engine oil.

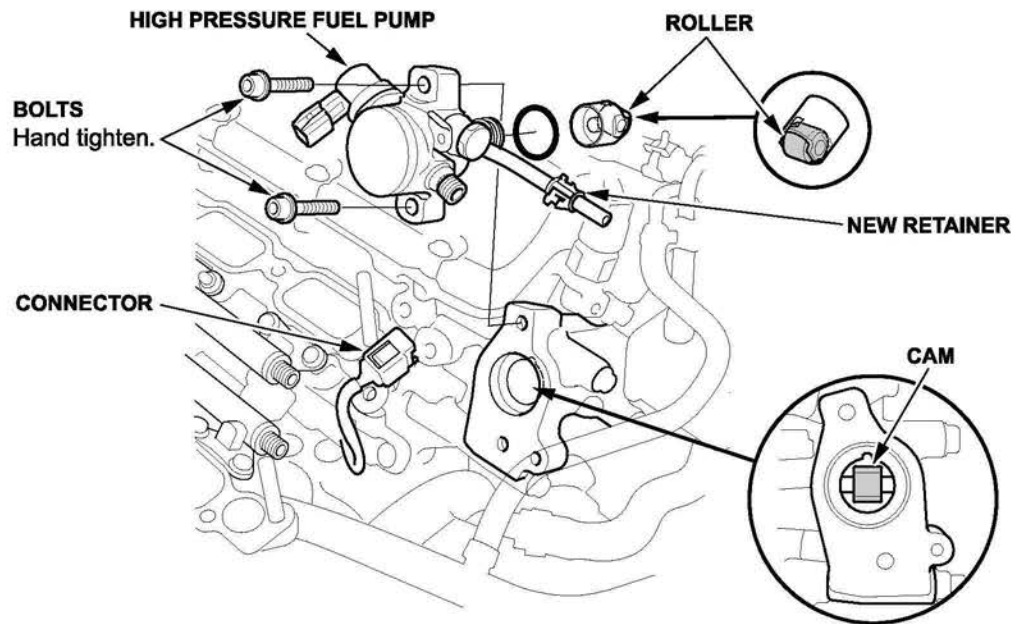

18. Install the roller and the high pressure fuel pump. Install the bolts loosely by hand in an alternate pattern. Connect the connector.

NOTE: Failure to install a new fuel joint pipe will cause fuel leaks.

19. Lubricate the top of the new fuel joint pipe and the threaded area of the fuel rails and the high pressure fuel pump with polyethylene glycol included in the new fuel joint pipe kit.

NOTE: Do not reuse the fuel joint pipe.

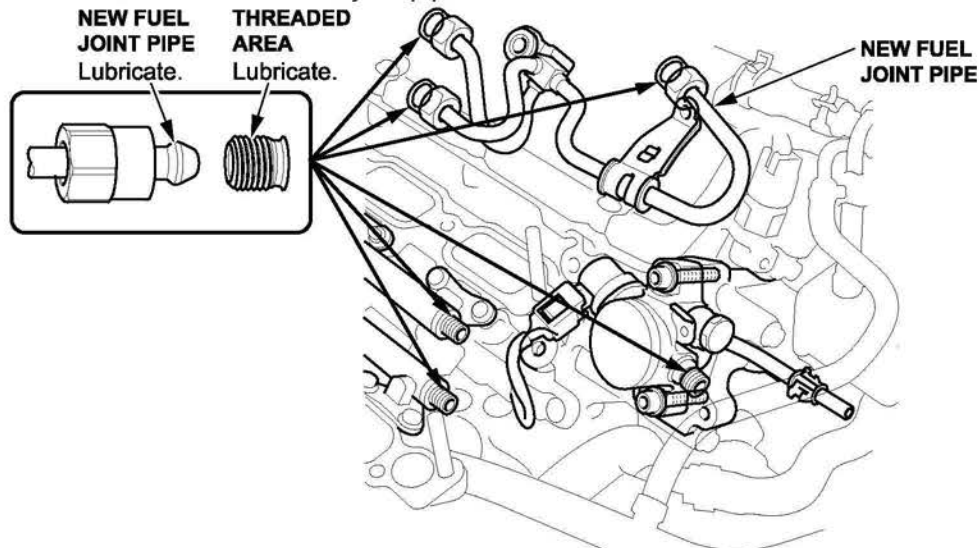

20. Tighten the fuel joint pipe nuts by hand until the end of the joint pipe is seated on the fuel rails and high pressure fuel pump.

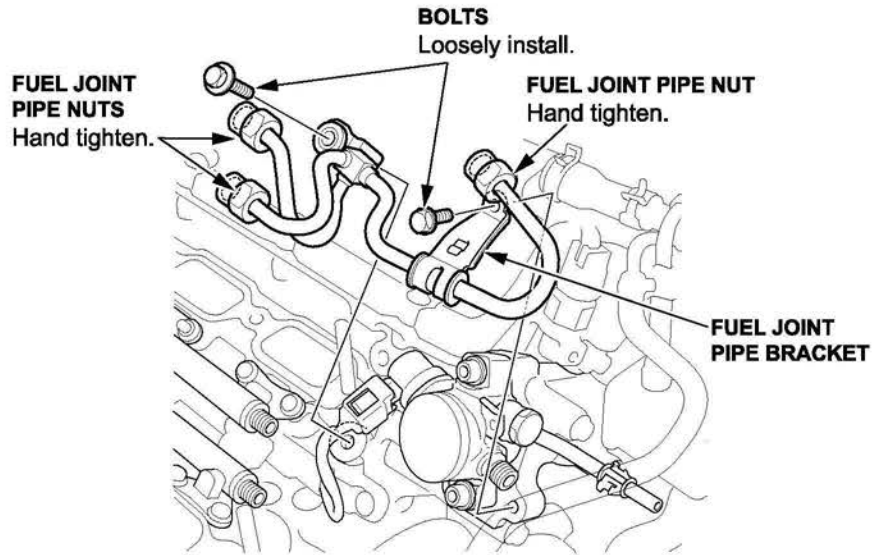

21. Set the fuel joint pipe bracket on the cylinder head and loosely install the bolts
22. Tighten the high pressure fuel pump mounting bolts to the specified torque.

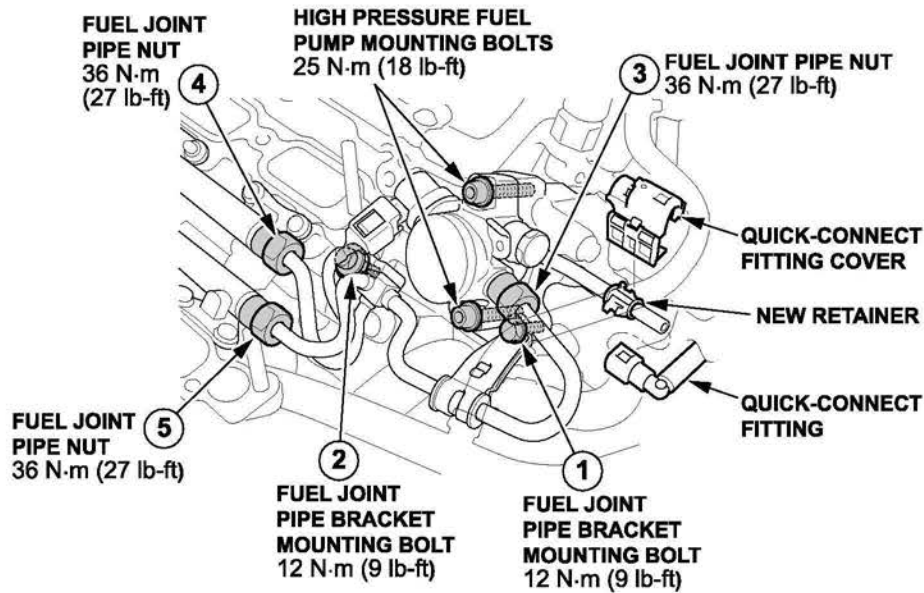

23. Tighten the fuel joint pipe bracket mounting bolts and the fuel joint pipe nuts to the specified torque in the numbered sequence shown.

**NOTE:**

- A crowfoot-type special tool increases the torque applied by the torque wrench. Refer to Torque Specifications for details on how to recalculate the torque wrench setting.
- Failure to tighten the fuel joint pipe nuts to the proper torque will cause a fuel leak.

24. Connect the quick-connect fitting and install the quick-connect fitting cover.

25. Set the power mode to ON, but do not start the engine. After the fuel pump runs for about 2 seconds, the fuel line will be pressurized. Repeat this two or three times, then check for fuel leakage.

26. Install the high pressure fuel pump cover and torque it to **12 N·m (9 lb-ft)**.

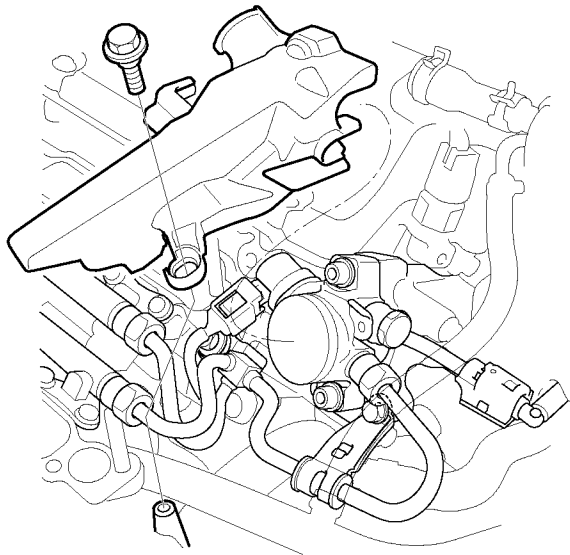

27. Install the intake base and intake manifold.

END