



Technical Service Bulletin

SUBJECT:		No: TSB-17-32-001	
TORQUE UPDATES: STEERING GEAR & LINKAGE – SERVICE MANUAL REVISION		DATE: January, 2017	
		MODEL: 2014–16 Outlander, 2011–16 Outlander Sport/RVR	
CIRCULATE TO:	<input type="checkbox"/> GENERAL MANAGER	<input checked="" type="checkbox"/> PARTS MANAGER	<input checked="" type="checkbox"/> TECHNICIAN
<input checked="" type="checkbox"/> SERVICE ADVISOR	<input checked="" type="checkbox"/> SERVICE MANAGER	<input type="checkbox"/> WARRANTY PROCESSOR	<input type="checkbox"/> SALES MANAGER

PURPOSE

This TSB updates the Power Plant Mount section of the affected Service Manuals to correct the clamping torque of steering gear and linkage in front crossmember removal and installation.

AFFECTED VEHICLES

- 2014 – 2016 Outlander
- 2011 – 2016 Outlander Sport/RVR

AFFECTED SERVICE MANUALS

- 2014 – 2016 Outlander Service Manual, Group 32 – Power Plant Mount –> Crossmember –> Removal and Installation
- 2011 – 2016 Outlander Sport/RVR Service Manual, Group 32 – Power Plant Mount –> Crossmember –> Removal and Installation



Please make the indicated changes to the 2014 – 2016 Outlander Service Manual, Group 32 – Power Plant Mount –> Crossmember –> Removal and Installation.

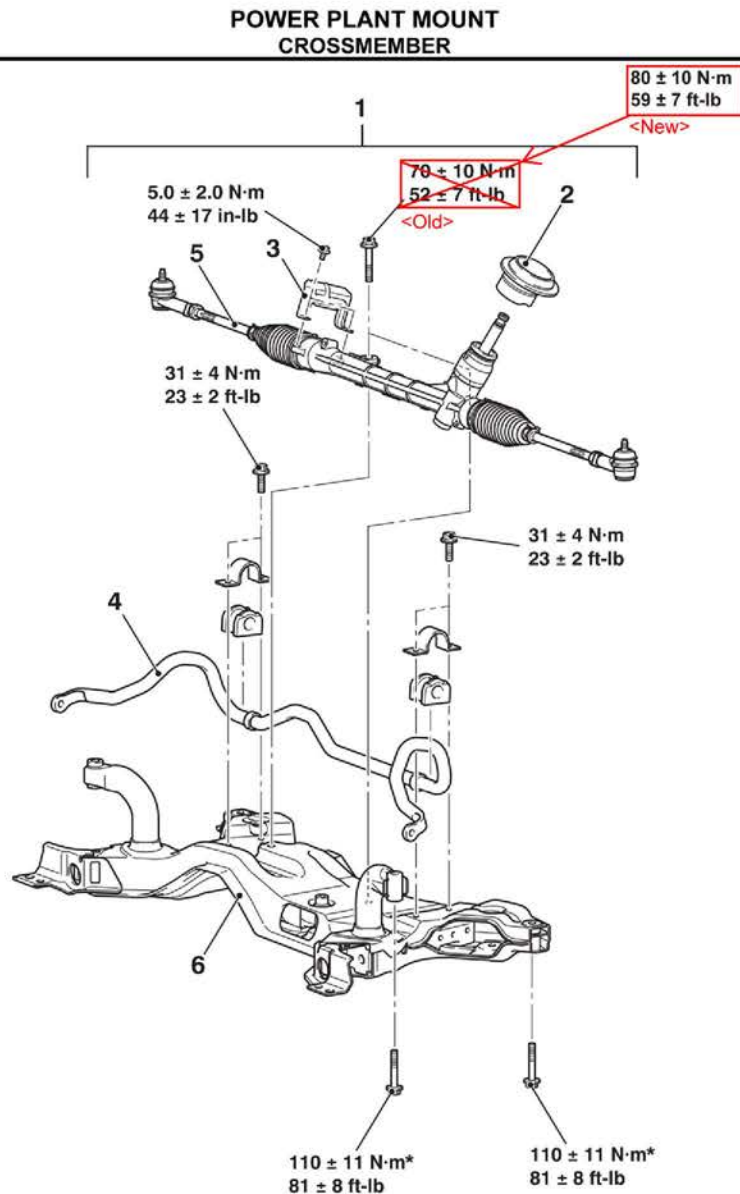

ACD00212AC

Removal steps

- Steering column bolt (Steering column shaft assembly and steering gear & linkage connection) (Refer to GROUP 37 – Steering Shaft P.37-69).
- Self-locking nut (Tie-rod end and knuckle connection) (Refer to GROUP 26 – Front Axle Hub Assembly P.26-9).
- Stabilizer link and stabilizer bar connection nut (Refer to GROUP 33 – Stabilizer Bar P.33-21).

<<A>>

>>A<<

Removal steps (Continued)

- Front end side panel mounting bolt (Refer to GROUP 42A – Loose Panel P.42A-247).
1. Front suspension crossmember assembly
 2. Joint cover grommet
 3. Heat protector <3.0 L Engine>
 4. Stabilizer bar (Refer to GROUP 33 – Stabilizer Bar P.33-21).
 5. Steering gear and linkage assembly
 6. Front suspension crossmember

Please make the indicated changes to the 2011 – 2016 Outlander Sport/RVR Service Manual, Group 32 – Power Plant Mount –> Crossmember –> Removal and Installation.

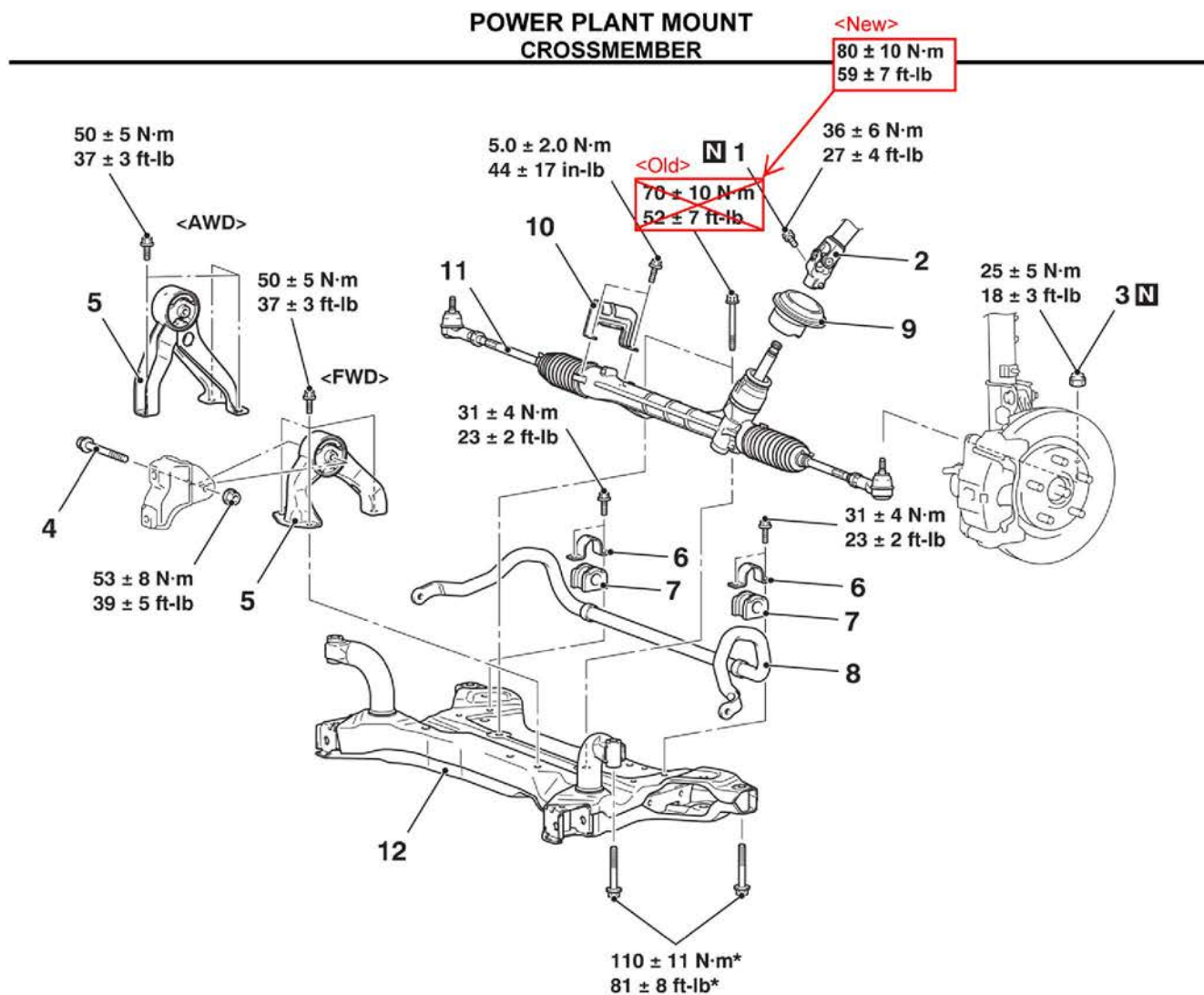

ACA03227AB

- | | | | |
|-------|---|-------|--|
| | Removal steps | | Removal steps (Continued) |
| >>D<< | 1. Steering column bolt | | 5. Rear roll stopper |
| >>D<< | 2. Steering column shaft assembly and steering gear and linkage assembly connection | >>C<< | 6. Stabilizer bar bracket |
| <<A>> | 3. Self-locking nut (Tie-rod end and knuckle connection) | >>B<< | 7. Stabilizer bushing |
| <> | 4. Rear roll stopper center bolt | >>A<< | 8. Stabilizer bar |
| | • Front axle crossmember assembly | | 9. Joint cover grommet |
| | | | 10. Heat protector |
| | | | 11. Steering gear and linkage assembly |
| | | | 12. Front axle crossmember |

Required Special Tool:

- MB991897 or MB992011: Ball Joint Remover