

## 2017 GSX-R1000/A Fuel Tank Drain and Breather Hoses

**Affected Models:** 2017 GSX-R1000/A

**Affected Departments:** Management, Service

When servicing 2017 GSX-R1000/A models, ensure that the fuel tank drain hose and fuel tank breather hose No. 1 are not pinched between the fuel tank and the fuel tank cushion. Also confirm the hoses are not routed to the outside of the fuel tank cushion.



*Example of fuel tank drain hose pinched between the fuel tank and the fuel tank cushion*



*Example of hoses incorrectly routed to the outside of the fuel tank cushion*

**When servicing 2017 GSX-R1000/A models involving fuel tank removal, observe the following procedure for reinstalling the fuel tank.**

### Installation Procedure:

From the right side of the motorcycle, shine a light between the upper frame rail and the front frame cover assembly, and visually inspect the fuel tank drain hose and fuel tank breather hose No. 1.



The hoses should be routed correctly, as shown below.

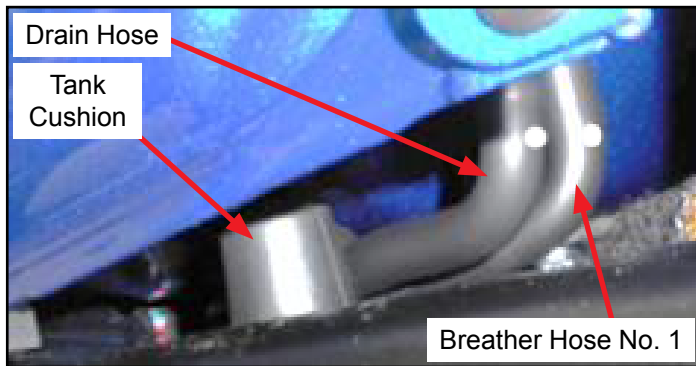

The fuel tank drain hose and breather hose No. 1 are routed to the inside of the tank cushion

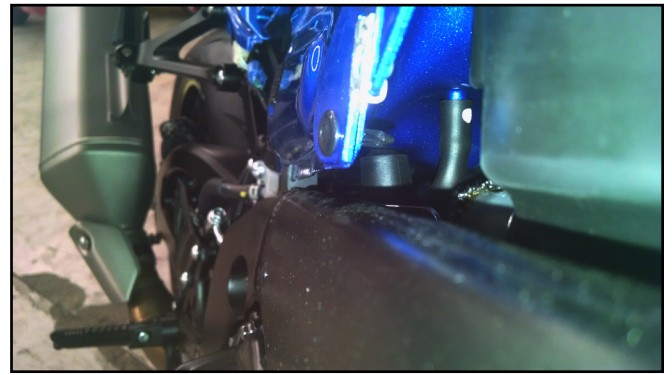

The white marks on both hoses face toward the front of the motorcycle

If the hoses are pinched between the fuel tank and fuel tank cushion, or the hoses are routed to the outside of the fuel tank cushion, do this:

- 1) Remove the frame front cover assemblies.
  - A) Remove the screw (1).
  - B) Remove the left-side frame front cover assembly (2).
  - C) Remove the right-side frame front cover assembly using the same process.

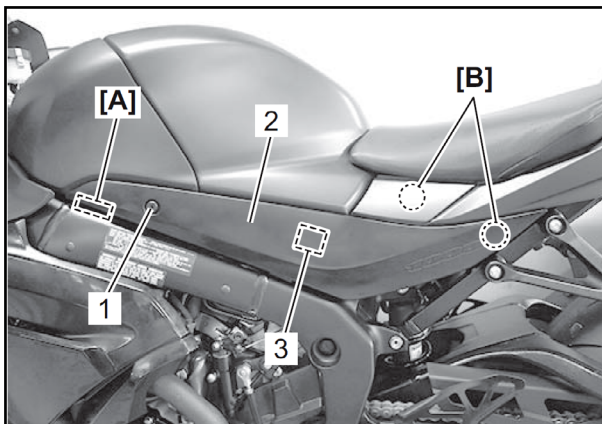

[A] Hooked Point, [B] Bushing, 3 - Velcro

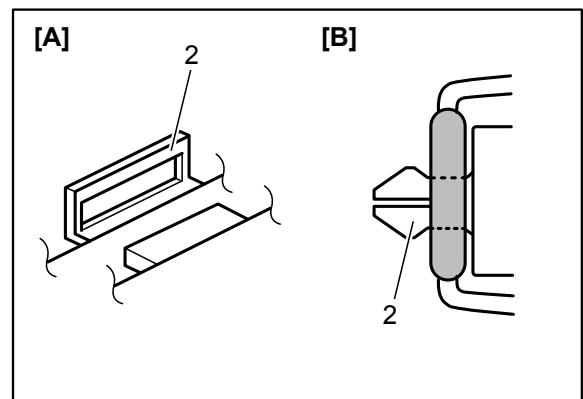

- 2) Remove the fuel tank front screws (1) and lift the front of the fuel tank.
- 3) Re-route the hoses to the inside of the fuel tank cushion. Do NOT twist or overlap the hoses.
- 4) Lower the front of the fuel tank and tighten the screws to the specified torque, then reinstall the frame front cover assemblies.

**Tightening Torque:**

**Fuel Tank Front Screws 5.5 N·m  
(0.56 kgf-m, 4.05 lbf-ft)**

