

FORD:

2012-2014 F-150

ISSUE

Some 2012-2014 F-150 vehicles equipped with an overhead console may exhibit a headliner sagging concern along the windshield and/or rear window glass.

ACTION

Follow the Service Procedure steps to correct the condition.

SERVICE PROCEDURE

1. Is the vehicle equipped with an overhead console?
 - a. Yes - proceed to Step 2.
 - b. No - this article does not apply. Refer to Workshop Manual (WSM), Section 501-05 for normal diagnostics.
2. Is the headliner sagging at the area(s) identified? (Figure 1)



Figure 1 - Article 17-0012

- a. Yes - proceed to Step 3.
 - b. No - this article does not apply. Refer to WSM, Section 501-05 for normal diagnostics.
3. Is the headliner showing any creasing, delamination or excess fraying of the cover material from the headliner?
 - a. Yes - this article does not apply. Refer to WSM, Section 501-05 for normal diagnostics.
 - b. No - proceed to Step 4.
4. Remove the headliner. Refer to WSM, Section 501-05.
 - a. Remove the audio digital signal processing (DSP) module, if equipped.
5. Place the headliner on a flat table with the backside facing up.
 - a. Make sure the flat surface or table is free of dirt, dust or debris.
6. Use the center notch of the front metal reinforcement to position it on the backside of the front edge of headliner. Use the dual notches when installing the rear metal reinforcement. (Figure 2)

NOTE: The information contained in Technical Service Bulletins is intended for use by trained, professional technicians with the knowledge, tools, and equipment to do the job properly and safely. It informs these technicians of conditions that may occur on some vehicles, or provides information that could assist in proper vehicle service. The procedures should not be performed by "do-it-yourselfers". Do not assume that a condition described affects your car or truck. Contact a Ford, Lincoln, or Mercury dealership to determine whether the bulletin applies to your vehicle. Warranty Policy and Extended Service Plan documentation determine Warranty and/or Extended Service Plan coverage unless stated otherwise in the TSB article. The information in this Technical Service Bulletin (TSB) was current at the time of printing. Ford Motor Company reserves the right to supersede this information with updates. The most recent information is available through Ford Motor Company's on-line technical resources.

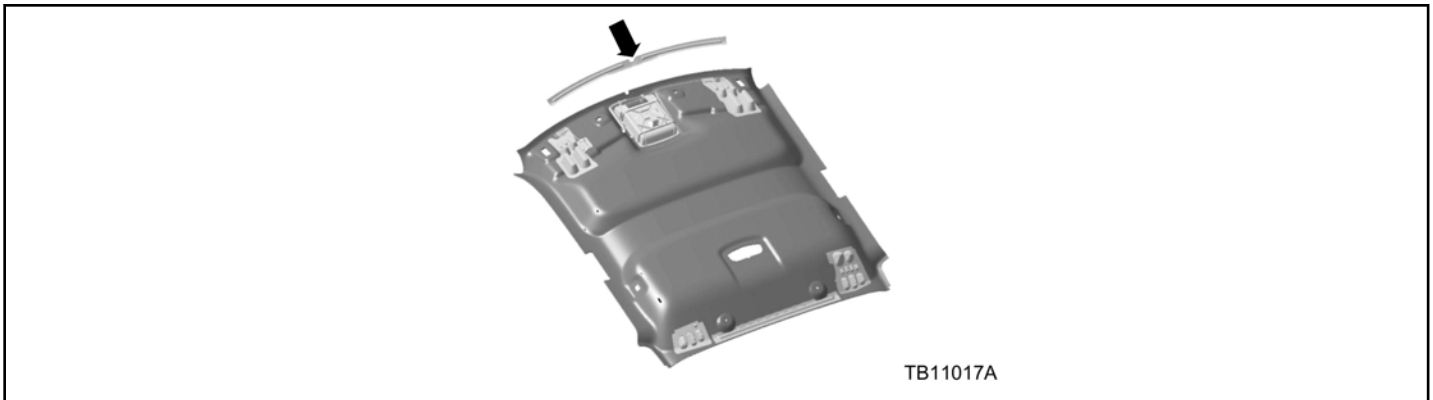

Figure 2 - Article 17-0012

7. With the metal reinforcement in place, trace the outline of the metal reinforcement on the backside of the headliner. This will be used as a guideline to apply adhesive on the headliner. Remove the metal reinforcement.
8. Using the 3M™ Performance Manual Applicator or equivalent, apply a generous bead of 3M™ Universal Adhesive or equivalent along the entire length of the metal reinforcement on the side which contacts the back side of the headliner and along the back side of the headliner previously marked.
9. Install the front and rear metal reinforcements on the backside of the headliner. Apply pressure along the length of headliner and metal reinforcement to make sure good contact is achieved between the parts.
10. Place and hold the installation support board over the front side of the headliner, opposite of the metal reinforcement. (Figure 3)

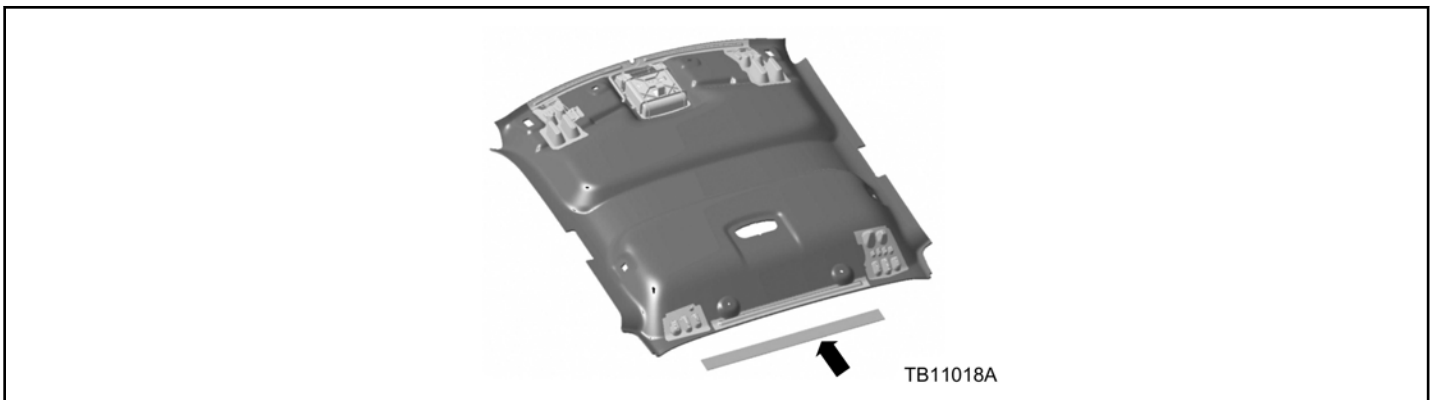

Figure 3 - Article 17-0012

- a. Starting at the center of the metal reinforcement, place a hand spring clamp over the installation support board, headliner and metal reinforcement. Secure in place.

TSB 17-0012 (Continued)

- b. Working in one direction, continue to apply additional spring clamps every 15 cm (6 inches) or as needed so the headliner conforms to the profile of the metal reinforcement. Make sure no gaps appear between the headliner and metal reinforcement. (Figure 4)

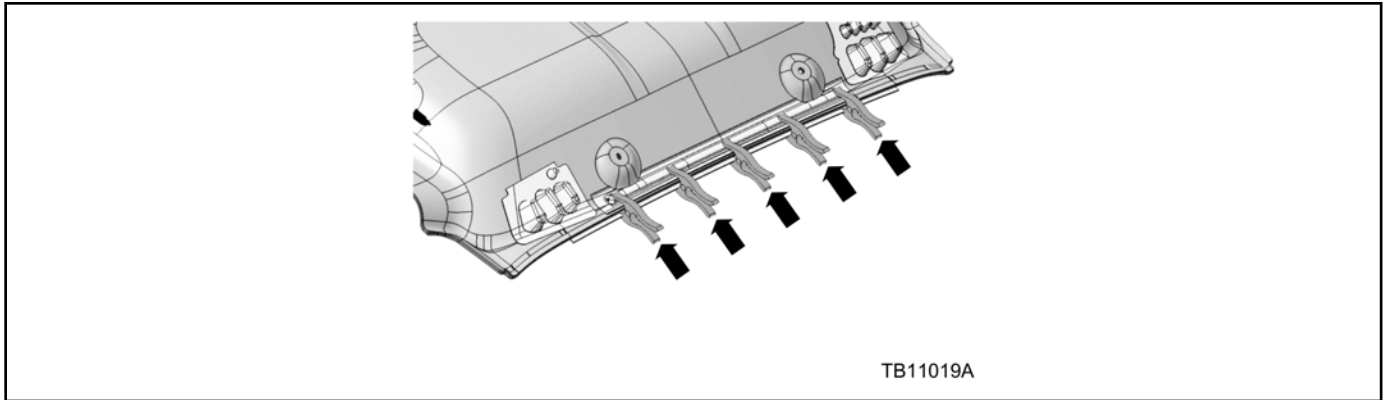

Figure 4 - Article 17-0012

- c. 3M™ Universal Adhesive has a 3 minute work time.
 - d. When fully clamped allow the adhesive to cure for 1 hour minimum. Clamps may be removed after 30 minutes, upon removal of the clamps discard the installation support board.
 - e. Make sure the weight of the clamps do not cause the headliner to crease.
 - f. If creasing is observed during cure time, place support under the affected area of the headliner.
11. Using the 3M™ Performance Manual Applicator or equivalent apply 3M™ Universal Adhesive or equivalent to reattach the wire harness to the backside of the headliner as necessary.
 12. Reinstall the headliner. Refer to WSM, Section 501-05.

Obtain Locally	
Part Number	Part Description
08107	3M™ Universal Adhesive Clear - Quantity Required - 2
08190	3M™ Performance Manual Applicator

PART NUMBER	PART NAME
FL3Z-1551916-A	Headliner Repair Kit

OPERATION	DESCRIPTION	TIME
170012A	2012-2014 F-150 Regular Cab: Install The Front And Rear Reinforcements Following The Service Procedure Includes Time To Remove And Install Headliner (Do Not Use With Any Other Labor Operations)	1.9 Hrs.
170012B	2012-2014 F-150 SuperCab: Install The Front And Rear Reinforcements Following The Service Procedure Includes Time To Remove And Install Headliner (Do Not Use With Any Other Labor Operations)	1.7 Hrs.
170012C	2012-2014 F-150 CrewCrew: Install The Front And Rear Reinforcements Following The Service Procedure Includes Time To Remove And Install Headliner (Do Not Use With Any Other Labor Operations)	4.1 Hrs.

WARRANTY STATUS:
Eligible Under Provisions Of New Vehicle Limited Warranty Coverage

Warranty/ESP coverage limits/policies/prior approvals are not altered by a TSB. Warranty/ESP coverage limits are determined by the identified causal part and verified using the OASIS part coverage tool.

DEALER CODING

BASIC PART NO.	CONDITION CODE
1551916	34