

LTB01093NAS2



# TECHNICAL BULLETIN

15 NOV 2017

© Jaguar Land Rover North America, LLC

NOTE: The information in Technical Bulletins is intended for use by trained, professional Technicians with the knowledge, tools, and equipment required to do the job properly and safely. It informs these Technicians of conditions that may occur on some vehicles, or provides information that could assist in proper vehicle service. The procedures should not be performed by 'do-it-yourselfers'. If you are not a Retailer, do not assume that a condition described affects your vehicle. Contact an authorized Land Rover service facility to determine whether this bulletin applies to a specific vehicle.

## INFORMATION

---

This reissue replaces all previous versions. Please destroy all previous versions.

---

### SECTION:

501-03: Body Closures

---

### SUBJECT/CONCERN:

Tailgate - Cosmetic Microcracking

---

### AFFECTED VEHICLE RANGE:

MODEL:	MODEL YEAR:	VIN:	ASSEMBLY PLANT:
Range Rover Evoque (LV)	2012	000447-000695	Halewood
Range Rover Evoque (LV)	2012-2015	600018-999999	Halewood
Range Rover Evoque (LV)	2015 Onwards	000051 Onwards	Halewood
Range Rover Sport (LW)	2014-2015	300003-399999	Solihull
Range Rover Sport (LW)	2014-2016	500023-599999	Solihull
Range Rover Sport (LW)	2014 Onwards	600000 Onwards	Solihull
Range Rover Sport (LW)	2016 Onwards	100369 Onwards	Solihull
Range Rover (LG)	2013 Onwards	000001 Onwards	Solihull

---

## MARKETS:

NORTH AMERICA

---

## CONDITION SUMMARY:

### SITUATION:

Cosmetic microcracking / surface cracks may be visible on the inside of the tailgate in the area of the hinge.

### CAUSE:

This may be caused by overextension of the tailgate.

### ACTION:

Should a customer or technician express this concern, refer to the Service Information and then follow the Workshop Procedure below.

---

## PARTS:

PART NUMBER	DESCRIPTION	QUANTITY
LR111581	Repair kit -Cirrus	1
LR111582	Repair kit -Ivory	1
LR111583	Repair kit -Black	1

---

**WARRANTY:**
**NOTES:**

- Repair procedures are under constant review, and therefore times are subject to change; those quoted here must be taken as guidance only. Always refer to JLR claims submission system to obtain the latest repair time.
- The JLR Claims Submission System requires the use of causal part numbers. Labor only claims must show the causal part number with a quantity of zero.

DESCRIPTION	SRO	TIME (HOURS)	CONDITION CODE	CAUSAL PART
Tailgate - Microcracking - Repair - One Side	76.28.89.86	0.4	01	LR071406
Tailgate - Microcracking - Repair - Both Sides	76.28.89.87	0.6	01	LR071406

**NOTE:**

Normal Warranty procedures apply.

---

**SERVICE INFORMATION:**
**NOTE:**

Some parts are shown removed for clarity.

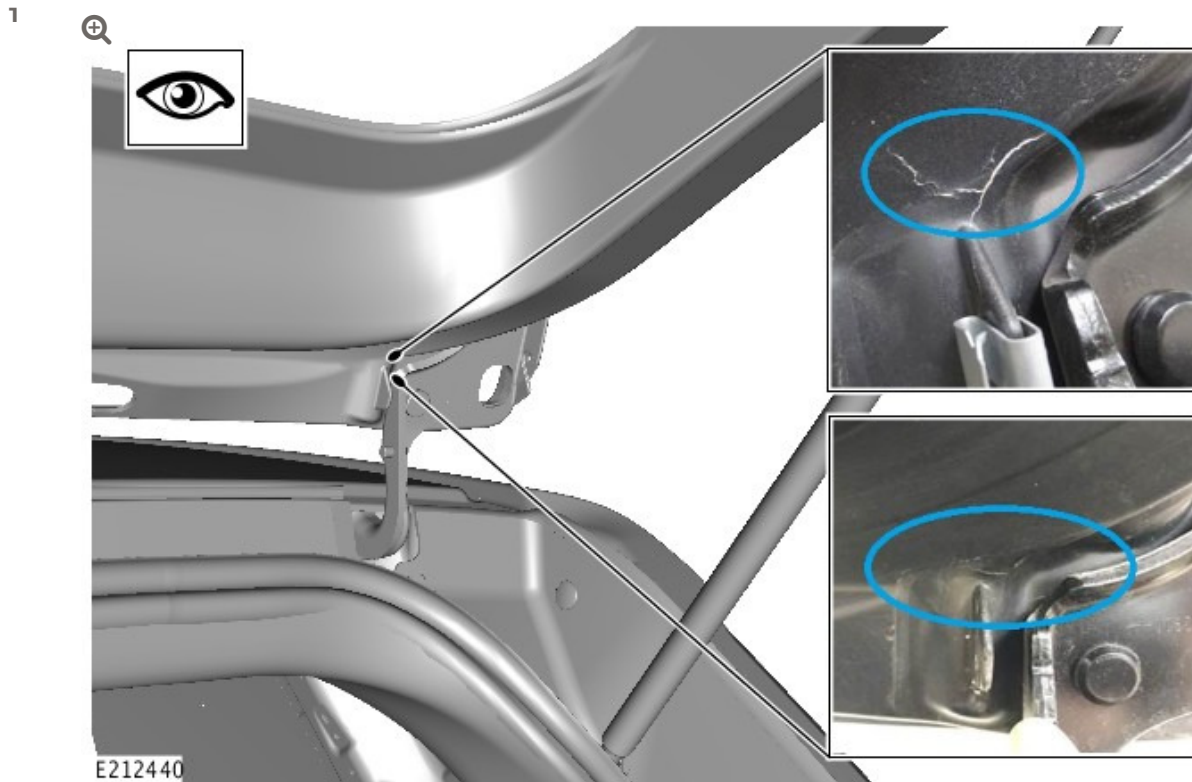

Typical location of the microcracking (can occur on either or both sides of the tailgate).

2

**NOTE:**

The kit also includes surface cleaner wipes (not shown).

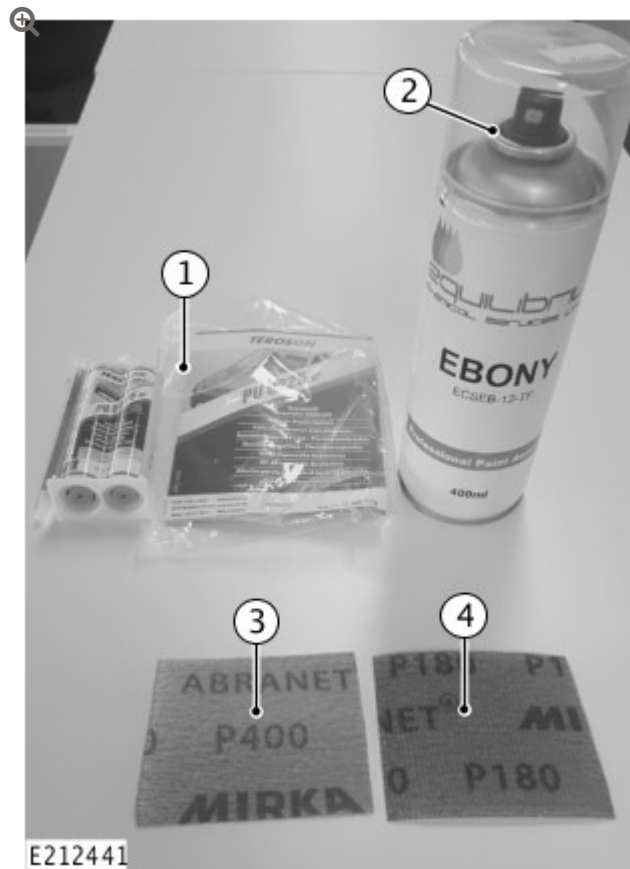

Contents of the repair kit.

- (1) TEROSON PU 9225 filler
- (2) EQUILIBRIUM spray paint
- (3) Sandpaper - P400
- (4) Sandpaper - P180

WORKSHOP PROCEDURE:

---

**CAUTION:**

The appropriate paintwork and trim protection to the vehicle exterior and interior must be fitted before commencing this Workshop Procedure.

---

1

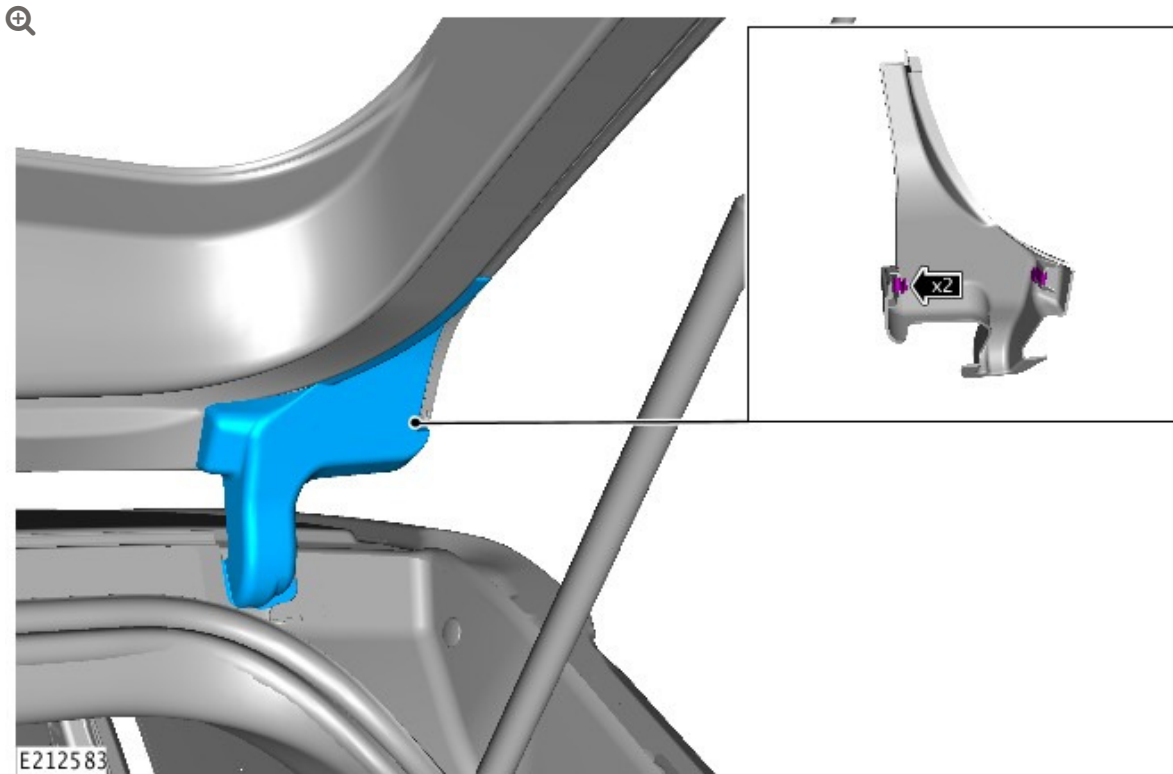

Remove the tailgate hinge trim.

2

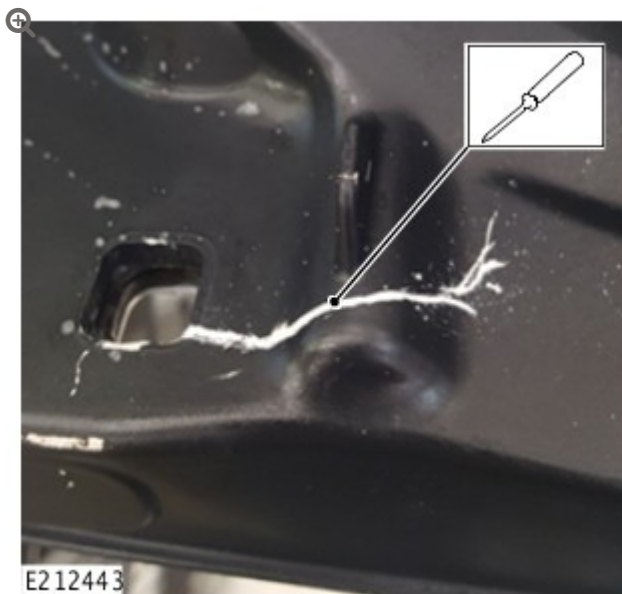

Using a suitable flat blade screwdriver, open up the microcrack so the filler can be applied.

3



Using the sandpaper in the repair kit prepare the microcracks for the filler.

- Stage 1: **P180**.
- Stage 2: **P400**.

---

4



Clean the surface using the surface cleaner wipes from the repair kit.





Mix the TEROSON PU 9225 filler from the repair kit and apply to the microcracks as shown.



Leave the filler to cure for 15 minutes.

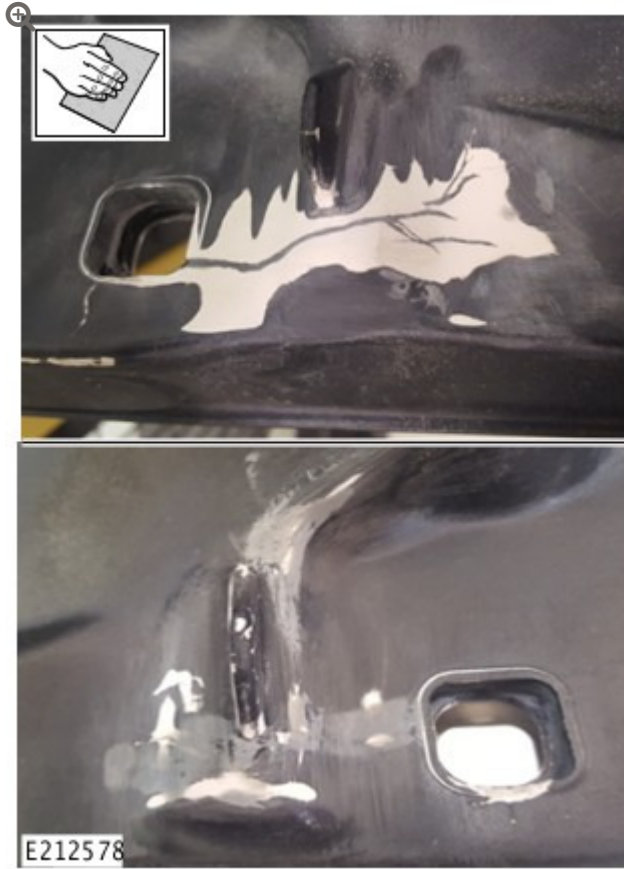

Using the P400 sandpaper from the repair kit, flatten the filler.

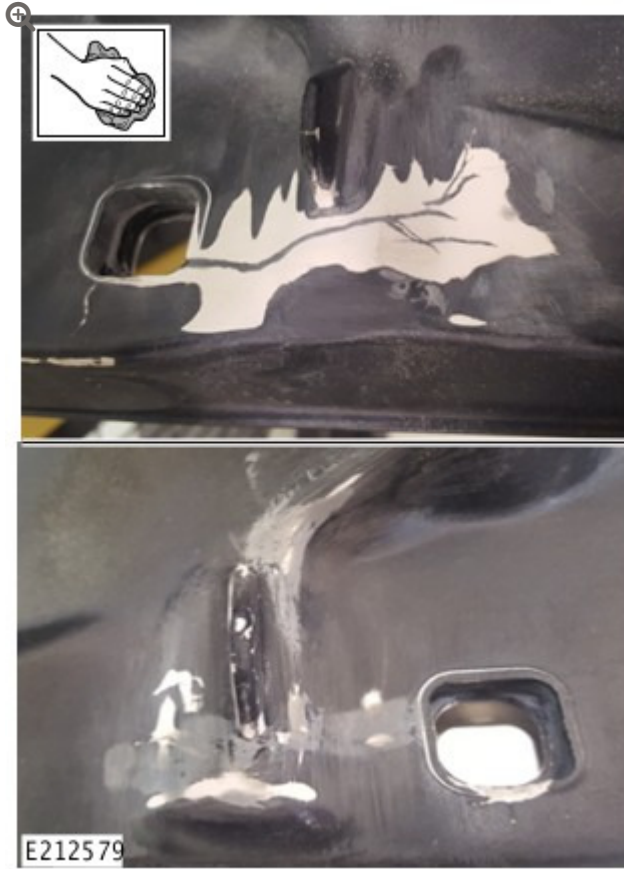

Clean the surface using the surface cleaner wipes from the repair kit.



Paint the repaired area with the EQUILIBRIUM spray paint from the repair kit.



Allow the paint to dry for 15 minutes.

- 
- 11 To install, reverse the removal procedure.
- 
- 12 If required, repeat steps 1-11 for the other side of the vehicle.