

<b>Subject:</b> <b>OIL LEAK FROM COMPANION FLANGE AREA OF TRANSFER UNIT</b>	<b>Bulletin No.:</b> 03-002/17
	<b>Last Issued:</b> 11/20/2017

## DESCRIPTION

### APPLICABLE MODEL(S)/VINS

2013-2016 CX-5 AWD vehicles with VINs lower than JM3KE\*\*\*\*\*878977 (produced before October 5, 2016)

Some vehicles may exhibit an oil leak from the companion flange area (A) of the transfer unit. This concern may be caused by companion flange oil seal wear. The oil seal has been improved to increase the wear resistance.

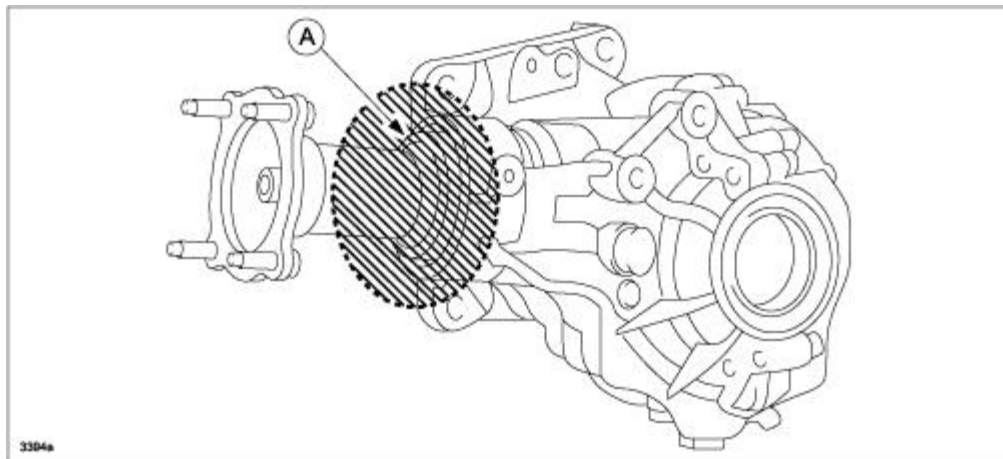

Customers having this concern should have their vehicle repaired using the following repair procedure.

## REPAIR PROCEDURE

1. Verify the customer concern.

**NOTE:** First try to replace the oil seal without disassembling the transfer unit. If this is not applicable or effective, disassemble the transfer unit.

### Companion Flange Oil Seal Replacement Procedure without disassembling the Transfer Unit

**CONSUMER NOTICE:** The information and instructions in this bulletin are intended for use by skilled technicians. Mazda technicians utilize the proper tools/equipment and take training to correctly and safely maintain Mazda vehicles. These instructions should not be performed by "do-it-yourselfers." Customers should not assume this bulletin applies to their vehicle or that their vehicle will develop the described concern. To determine if the information applies, customers should contact their nearest authorized Mazda dealership. Mazda North American Operations reserves the right to alter the specifications and contents of this bulletin without obligation or advance notice. All rights reserved. No part of this bulletin may be reproduced in any form or by any means, electronic or mechanical---including photocopying and recording and the use of any kind of information storage and retrieval system ---without permission in writing.

(Without replacing Collapsible Spacer):

**IMPORTANT:**

- This procedure can only be used one time because the collapsible spacer will already be collapsed and its function will be lost.
- This procedure requires precise measurement of the bearing preload. Carefully read through the procedure and understand the work flow and required skills before starting to work.

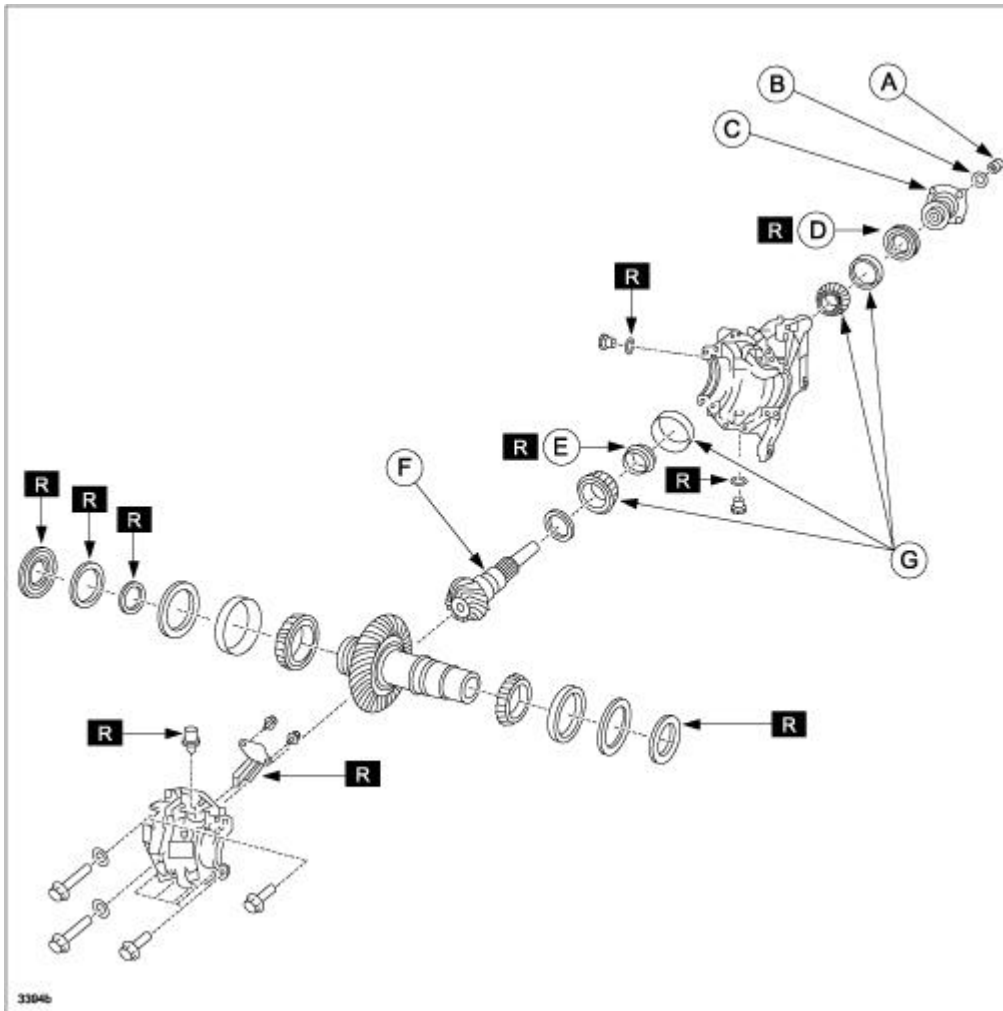

**CONSUMER NOTICE:** The information and instructions in this bulletin are intended for use by skilled technicians. Mazda technicians utilize the proper tools/equipment and take training to correctly and safely maintain Mazda vehicles. These instructions should not be performed by "do-it-yourselfers." Customers should not assume this bulletin applies to their vehicle or that their vehicle will develop the described concern. To determine if the information applies, customers should contact their nearest authorized Mazda dealership. Mazda North American Operations reserves the right to alter the specifications and contents of this bulletin without obligation or advance notice. All rights reserved. No part of this bulletin may be reproduced in any form or by any means, electronic or mechanical---including photocopying and recording and the use of any kind of information storage and retrieval system ---without permission in writing.

	Part Description	Notes
A	Lock Nut (*)	REUSE
B	Washer (*)	REUSE
C	Companion Flange Component (*)	REUSE
D	<b>Oil Seal</b>	<b>REPLACE</b>
E	Collapsable Spacer	DO NOT REMOVE
F	Pinion Shaft	DO NOT REMOVE
G	Bearing	DO NOT REMOVE

(\*) Reinstall lock nut, washer and companion flange component after replacing the oil seal, in the original position, so that the same bearing preload value can be assured before disassembly and after assembly.

2. Verify that this is the first time replacing the oil seal using this procedure.

**NOTE:** Confirm it by checking the vehicle repair history and/or existence of position marks on the companion flange, lock nut and pinion shaft during the previous oil seal replacement.

- If the oil seal has been previously replaced using this procedure, this procedure must not be used again. Replace the oil seal by disassembling the transfer unit. Go to **“Companion Flange Oil Seal Replacement Procedure by Disassembling Transfer Unit”**.
- If this is the first time replacing the oil seal using this procedure, go to next step.

3. Remove the propeller shaft according to the instructions on MGSS online (PROPELLER SHAFT REMOVAL/INSTALLATION).

4. Measure the bearing (A) preload by turning the pinion shaft (B) within the backlash range of the hypoid gear (C).

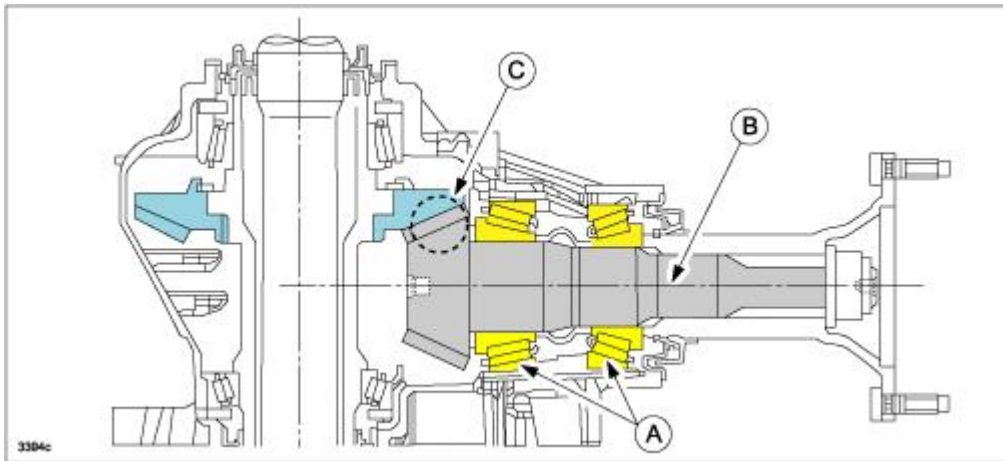

**CONSUMER NOTICE:** The information and instructions in this bulletin are intended for use by skilled technicians. Mazda technicians utilize the proper tools/equipment and take training to correctly and safely maintain Mazda vehicles. These instructions should not be performed by “do-it-yourselfers.” Customers should not assume this bulletin applies to their vehicle or that their vehicle will develop the described concern. To determine if the information applies, customers should contact their nearest authorized Mazda dealership. Mazda North American Operations reserves the right to alter the specifications and contents of this bulletin without obligation or advance notice. All rights reserved. No part of this bulletin may be reproduced in any form or by any means, electronic or mechanical---including photocopying and recording and the use of any kind of information storage and retrieval system ---without permission in writing.

5. Record the measured value.

**NOTE:** If the backlash of hypoid gear is too small, it may be difficult to measure the bearing preload. In this case, this procedure is not effective. Disassemble the transfer unit to replace the oil seal. Go to **“Companion Flange Oil Seal Replacement Procedure by Disassembling Transfer Unit”**.

When measured with a torque wrench (A) or spring scale (B).

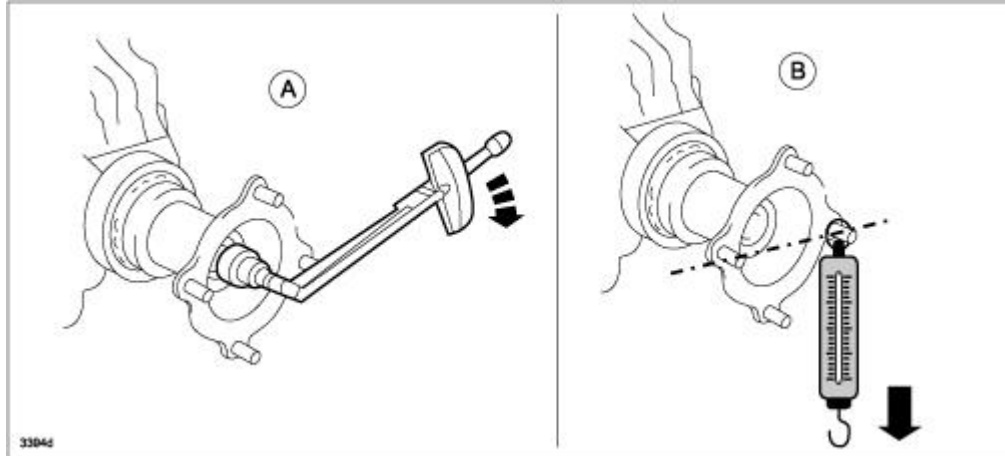

#### Upper Limit Value of Bearing Preload:

Method	Upper Limit Value
A. When measured with a torque wrench	1.44 Nm {14kgf-cm, 12 in-lbf}
B. When measured with a spring scale	2.83 kg

- If the preload is **less than** the upper limit value, go to next step.
- If the preload is **greater than** the upper limit value, the collapsible spacer needs to be replaced to adjust the preload and so this procedure must not be used. Disassemble the transfer unit to replace the oil seal. Go to **“Companion Flange Oil Seal Replacement Procedure by Disassembling Transfer Unit”**.

6. Put a position mark (A) over the companion flange (B), lock nut (C) and pinion shaft (D) as shown below.

**NOTE:** Be sure to put the mark clearly so that all three (3) parts can be reassembled in the same position.

**CONSUMER NOTICE:** The information and instructions in this bulletin are intended for use by skilled technicians. Mazda technicians utilize the proper tools/equipment and take training to correctly and safely maintain Mazda vehicles. These instructions should not be performed by “do-it-yourselfers.” Customers should not assume this bulletin applies to their vehicle or that their vehicle will develop the described concern. To determine if the information applies, customers should contact their nearest authorized Mazda dealership. Mazda North American Operations reserves the right to alter the specifications and contents of this bulletin without obligation or advance notice. All rights reserved. No part of this bulletin may be reproduced in any form or by any means, electronic or mechanical—including photocopying and recording and the use of any kind of information storage and retrieval system ---without permission in writing.

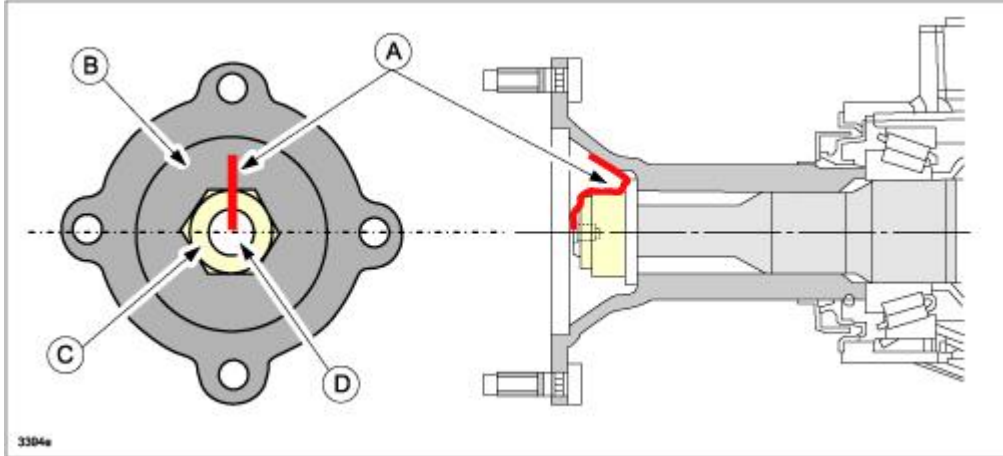

7. Secure the companion flange using the SST and remove the locknut.

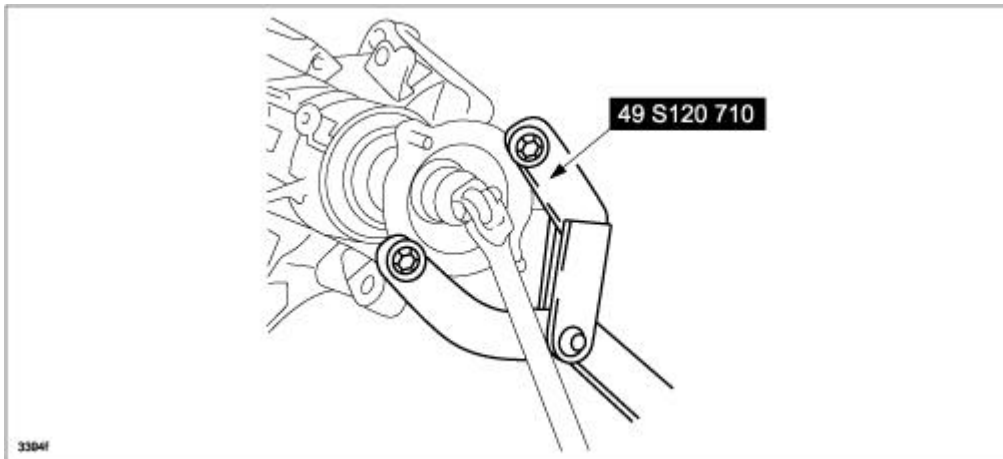

8. Remove the washer.

9. Remove the companion flange using the SST.

**CONSUMER NOTICE:** The information and instructions in this bulletin are intended for use by skilled technicians. Mazda technicians utilize the proper tools/equipment and take training to correctly and safely maintain Mazda vehicles. These instructions should not be performed by "do-it-yourselfers." Customers should not assume this bulletin applies to their vehicle or that their vehicle will develop the described concern. To determine if the information applies, customers should contact their nearest authorized Mazda dealership. Mazda North American Operations reserves the right to alter the specifications and contents of this bulletin without obligation or advance notice. All rights reserved. No part of this bulletin may be reproduced in any form or by any means, electronic or mechanical---including photocopying and recording and the use of any kind of information storage and retrieval system ---without permission in writing.

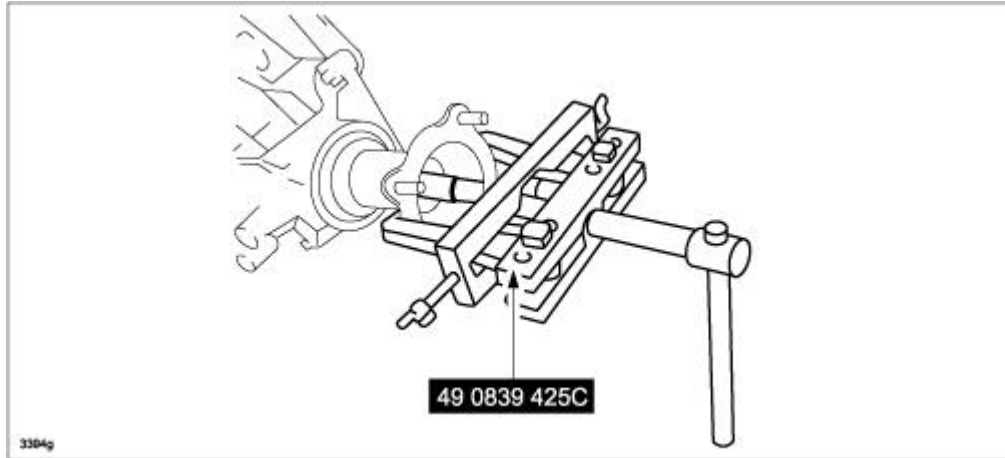

10. Remove the oil seal using a tape-wrapped flathead screwdriver.

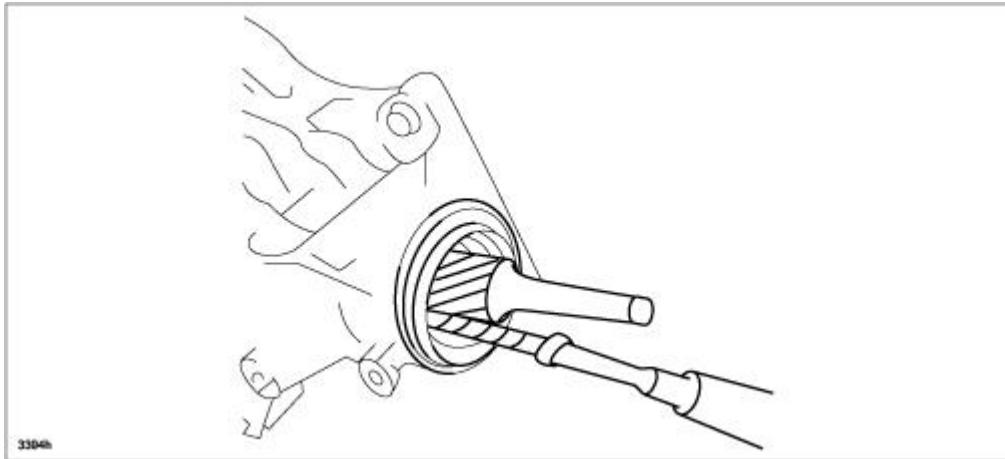

11. Install the modified oil seal using the SST.

**NOTE:**Place the B stamped side of the SST onto the oil seal side.

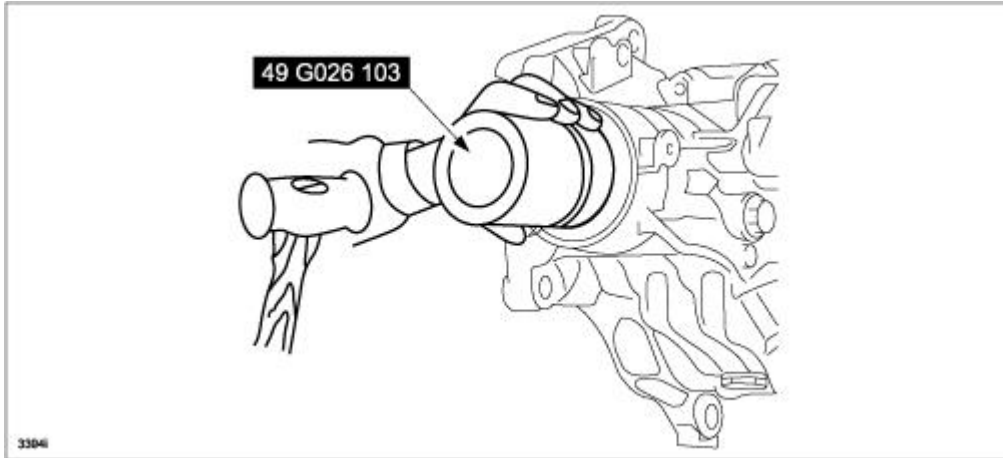

12. Apply grease to the area of the companion flange where it contacts the bearing inner race (rear).
13. Install the companion flange to the drive pinion gear component, aligning the position marks (A) on the companion flange and the pinion shaft.

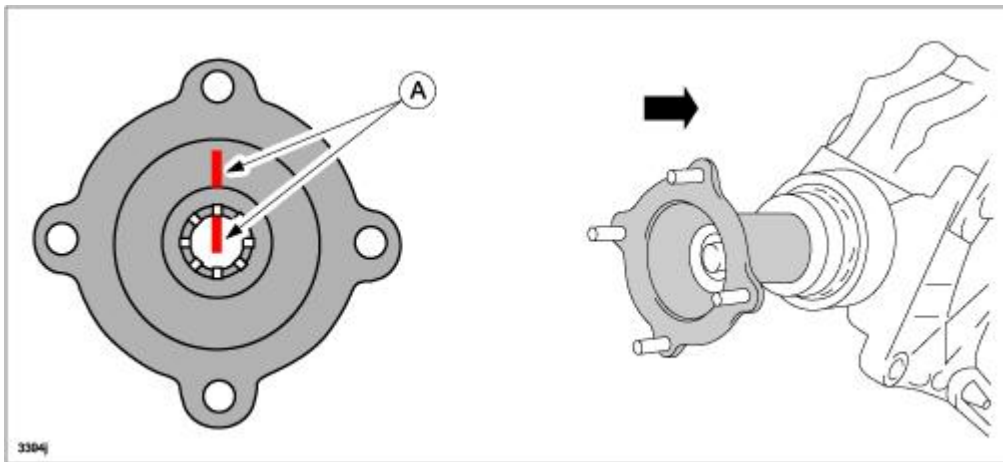

14. Install the washer, facing it in the same direction as when it was removed.
- NOTE:** If the direction of washer has changed, the drive pinion preload will change.

15. After applying transfer oil to the threaded area of the old locknut, temporarily tighten it.
- NOTE:** If the locknut cannot be installed, assemble the companion flange by lightly tapping it with a plastic hammer to start threading on the drive pinion gear.

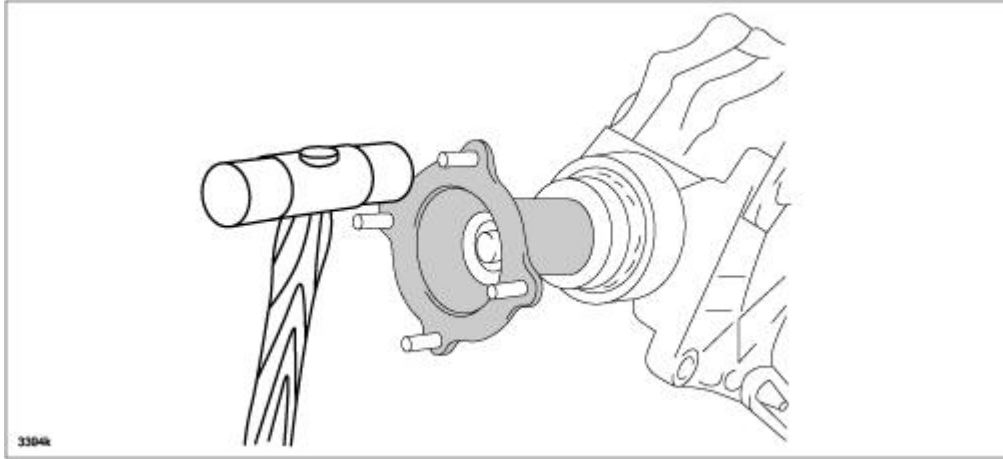

16. While checking the tightening torque with a torque wrench (A), tighten the lock nut (B) until the position mark (C) on the lock nut aligns with the position mark (D) on the companion flange.

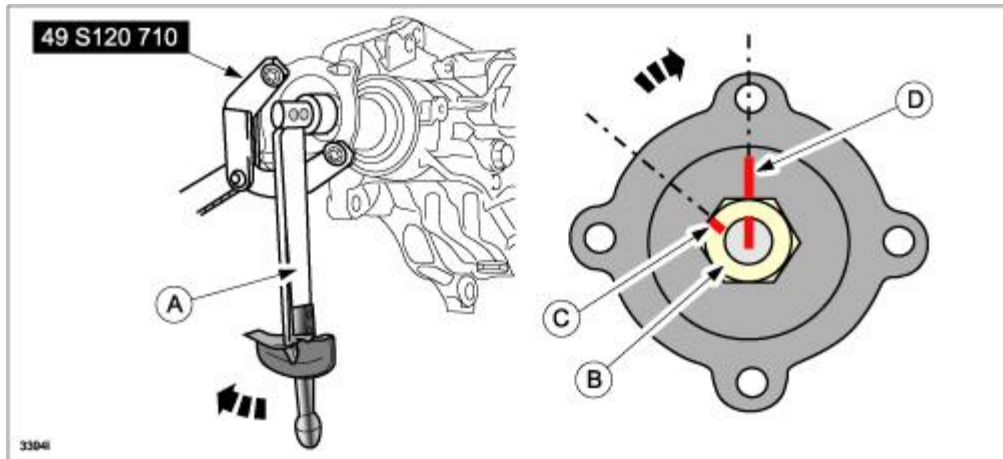

17. Record the locknut tightening torque value when it is tightened to the alignment mark.  
 - If the tightening torque is within the maximum specification, it is OK, go to next step.

#### Tightening Torque Specification:

**80 - 284 Nm {8.2 - 28 kgf-m, 60 - 209 ft-lbf}**

- If the tightening torque has exceeded the maximum specification, some internal problems are possible and this procedure is not effective. Disassemble the transfer unit to replace the oil seal. Go to **“Companion Flange Oil Seal Replacement Procedure by Disassembling Transfer Unit”**.

18. Measure the bearing preload using the same procedure as shown above, then compare it with the specifications below.

**CONSUMER NOTICE:** The information and instructions in this bulletin are intended for use by skilled technicians. Mazda technicians utilize the proper tools/equipment and take training to correctly and safely maintain Mazda vehicles. These instructions should not be performed by “do-it-yourselfers.” Customers should not assume this bulletin applies to their vehicle or that their vehicle will develop the described concern. To determine if the information applies, customers should contact their nearest authorized Mazda dealership. Mazda North American Operations reserves the right to alter the specifications and contents of this bulletin without obligation or advance notice. All rights reserved. No part of this bulletin may be reproduced in any form or by any means, electronic or mechanical---including photocopying and recording and the use of any kind of information storage and retrieval system ---without permission in writing.



**Bearing Preload Specification:**

No.	Method	Limit Value	Specification
1	Torque wrench	Upper Limit Value	(Value measured in above step) + 0.29 Nm (*)
2	Torque wrench	Lower Limit Value	(Value measured in above step) + 0.06 Nm (*)
3	Torque wrench	Upper Limit Value in Workshop Manual	1.44 Nm
1	Spring scale	Upper Limit Value	Upper Limit Value (Value measured in above step) + 0.57 Kg (*)
2	Spring scale	Lower Limit Value	(Value measured in above step) + 0.12 Kg (*)
3	Spring scale	Upper Limit Value in Workshop Manual	2.83 Kg

**NOTE (\*)**: This value is a tolerance plus a value that is increased by resistance of the new oil seal installed.

- If the preload is within all three (3) limit values (above), it is ok, go to next step.
- If the preload is outside one or more of the three (3) limit values (above), the procedure is not effective. Disassemble the transfer unit to replace the oil seal. Go to **“Companion Flange Oil Seal Replacement Procedure by Disassembling Transfer Unit”**.

19. Reinstall the propeller shaft according to the instructions on MGSS online (PROPELLER SHAFT REMOVAL/INSTALLATION).

**Companion Flange Oil Seal Replacement Procedure by Disassembling Transfer Unit:**

Replace the oil seal according to the instructions on MGSS online (TRANSFER REMOVAL/INSTALLATION [FW6AX-EL]) and the applicable Transmission/Transaxle workshop manual (TRANSFER DISASSEMBLY/ASSEMBLY).

20. Verify the repair.

**PARTS INFORMATION**

1. When the companion flange oil seal is replaced **without** disassembling the transfer unit.

**CONSUMER NOTICE:** The information and instructions in this bulletin are intended for use by skilled technicians. Mazda technicians utilize the proper tools/equipment and take training to correctly and safely maintain Mazda vehicles. These instructions should not be performed by “do-it-yourselfers.” Customers should not assume this bulletin applies to their vehicle or that their vehicle will develop the described concern. To determine if the information applies, customers should contact their nearest authorized Mazda dealership. Mazda North American Operations reserves the right to alter the specifications and contents of this bulletin without obligation or advance notice. All rights reserved. No part of this bulletin may be reproduced in any form or by any means, electronic or mechanical---including photocopying and recording and the use of any kind of information storage and retrieval system ---without permission in writing.

Part Number	Description	Qty.	Notes
KN01-27-165A	Oil seal	1	(REPLACE) Illustration No. 10

2. When the companion flange oil seal is replaced **with** disassembling the transfer unit.

#### Transfer, Remove & Install:

Part Number	Description	Qty.	Notes
PE17-13-460	Gasket, Exhaust Manifold	1	(REPLACE) For PE Engine only
PY01-13-460	Gasket, Exhaust Manifold	1	(REPLACE) For PY Engine only
PE23-40-305	Gasket	1	(REPLACE) For PE/PY Engine only
9994-61-000	Nut, Exhaust Manifold	2	(REPLACE) For PE/PY Engine only
B455-32-099B	Bolt, Intermediate Shaft	1	(REPLACE)
D651-33-042A	Lock Nut, Drive Shaft	1	(REPLACE)
T060-26-169A	Snap Pin, Ball Joint	1	(REPLACE)
9956-41-800	Washer, Drain Plug	2	(REPLACE) For MTX
9956-41-400	Washer, Drain Plug	1	(REPLACE) For ATX
Use applicable No.	AT Fluid	---	For topping it up

#### Transfer, Overhaul:

**CONSUMER NOTICE:** The information and instructions in this bulletin are intended for use by skilled technicians. Mazda technicians utilize the proper tools/equipment and take training to correctly and safely maintain Mazda vehicles. These instructions should not be performed by "do-it-yourselfers." Customers should not assume this bulletin applies to their vehicle or that their vehicle will develop the described concern. To determine if the information applies, customers should contact their nearest authorized Mazda dealership. Mazda North American Operations reserves the right to alter the specifications and contents of this bulletin without obligation or advance notice. All rights reserved. No part of this bulletin may be reproduced in any form or by any means, electronic or mechanical---including photocopying and recording and the use of any kind of information storage and retrieval system ---without permission in writing.

Part Number	Description	Qty.	Notes
0730-26-060	Breather	1	(REPLACE) Illustration No. 1
KN01-27-326	Baffle plate	1	(REPLACE) Illustration No. 2
CN01-27-397	Transfer oil seal (RH) No.1	1	(REPLACE) Illustration No. 3
KN01-27-398	Transfer oil seal (RH) No.2	1	(REPLACE) Illustration No. 4
KN01-27-514	Transfer oil seal (RH) No.3	1	(REPLACE) Illustration No. 5
KN01-27-238	Transfer oil seal (LH)	1	(REPLACE) Illustration No. 6
KN01-27-171	Collapsible spacer	1	(REPLACE) Illustration No. 7
9956-41-800	Oil level plug, washer	2	(REPLACE) Illustration No. 8 and 9
KN01-27-165A	Oil seal	1	(REPLACE) Illustration No. 10
0223-27-030	Locknut	1	(REPLACE) Illustration No. 11
CAY1-27-156	Silicone Sealant TB1217C (Equivalent can be used)	1	If the sealant is procured locally, claim the actual amount by SUBLET...
Select one from Shim Table below	Adjustment Shim (RH)	1	Illustration No. 12
Select one from Shim Table below	Adjustment Shim (LH)	1	Illustration No. 13

**(ADJUSTMENT SHIM TABLE (LH))**

**CONSUMER NOTICE:** The information and instructions in this bulletin are intended for use by skilled technicians. Mazda technicians utilize the proper tools/equipment and take training to correctly and safely maintain Mazda vehicles. These instructions should not be performed by "do-it-yourselfers." Customers should not assume this bulletin applies to their vehicle or that their vehicle will develop the described concern. To determine if the information applies, customers should contact their nearest authorized Mazda dealership. Mazda North American Operations reserves the right to alter the specifications and contents of this bulletin without obligation or advance notice. All rights reserved. No part of this bulletin may be reproduced in any form or by any means, electronic or mechanical---including photocopying and recording and the use of any kind of information storage and retrieval system ---without permission in writing.

Part Number	Thickness (mm {IN})	Part Number	Thickness (mm {IN})
KN01-27-3D1	4.490 {0.1768}	KN01-27-3F1	5.030 {0.1980}
KN01-27-3D2	4.520 {0.1780}	KN01-27-3F2	5.060 {0.1992}
KN01-27-3D3	4.550 {0.1791}	KN01-27-3F3	5.090 {0.2004}
KN01-27-3D4	4.580 {0.1803}	KN01-27-3F4	5.120 {0.2016}
KN01-27-3D5	4.610 {0.1815}	KN01-27-3F5	5.150 {0.2028}
KN01-27-3D6	4.640 {0.1827}	KN01-27-3F6	5.180 {0.2039}
KN01-27-3D7	4.670 {0.1839}	KN01-27-3F7	5.210 {0.2051}
KN01-27-3D8	4.700 {0.1850}	KN01-27-3F8	5.240 {0.2063}
KN01-27-3D9	4.730 {0.1862}	KN01-27-3F9	5.270 {0.2075}
KN01-27-3E1	4.760 {0.1874}	KN01-27-3G1	5.300 {0.2087}
KN01-27-3E2	4.790 {0.1886}	KN01-27-3G2	5.330 {0.2098}
KN01-27-3E3	4.820 {0.1898}	KN01-27-3G3	5.360 {0.2110}
KN01-27-3E4	4.850 {0.1909}	KN01-27-3G4	5.390 {0.2122}
KN01-27-3E5	4.880 {0.1921}	KN01-27-3G5	5.420 {0.2134}
KN01-27-3E6	4.910 {0.1933}	KN01-27-3G6	5.450 {0.2146}
KN01-27-3E7	4.940 {0.1945}	KN01-27-3G7	5.480 {0.2157}
KN01-27-3E8	4.970 {0.1957}	KN01-27-3G8	5.510 {0.2169}
KN01-27-3E9	5.000 {0.1969}	---	---

**(ADJUSTMENT SHIM TABLE (RH))**

**CONSUMER NOTICE:** The information and instructions in this bulletin are intended for use by skilled technicians. Mazda technicians utilize the proper tools/equipment and take training to correctly and safely maintain Mazda vehicles. These instructions should not be performed by "do-it-yourselfers." Customers should not assume this bulletin applies to their vehicle or that their vehicle will develop the described concern. To determine if the information applies, customers should contact their nearest authorized Mazda dealership. Mazda North American Operations reserves the right to alter the specifications and contents of this bulletin without obligation or advance notice. All rights reserved. No part of this bulletin may be reproduced in any form or by any means, electronic or mechanical---including photocopying and recording and the use of any kind of information storage and retrieval system ---without permission in writing.

Part Number	Thickness (mm {IN})	Part Number	Thickness (mm {IN})
KN01-27-355	4.490 {0.1768}	KN01-27-375	5.030 {0.1980}
KN01-27-356	4.520 {0.1780}	KN01-27-376	5.060 {0.1992}
KN01-27-357	4.550 {0.1791}	KN01-27-377	5.090 {0.2004}
KN01-27-358	4.580 {0.1803}	KN01-27-378	5.120 {0.2016}
KN01-27-359	4.610 {0.1815}	KN01-27-379	5.150 {0.2028}
KN01-27-361	4.640 {0.1827}	KN01-27-3B1	5.180 {0.2039}
KN01-27-362	4.670 {0.1839}	KN01-27-3B2	5.210 {0.2051}
KN01-27-363	4.700 {0.1850}	KN01-27-3B3	5.240 {0.2063}
KN01-27-364	4.730 {0.1862}	KN01-27-3B4	5.270 {0.2075}
KN01-27-365	4.760 {0.1874}	KN01-27-3B5	5.300 {0.2087}
KN01-27-366	4.790 {0.1886}	KN01-27-3B6	5.330 {0.2098}
KN01-27-367	4.820 {0.1898}	KN01-27-3B7	5.360 {0.2110}
KN01-27-368	4.850 {0.1909}	KN01-27-3B8	5.390 {0.2122}
KN01-27-369	4.880 {0.1921}	KN01-27-3B9	5.420 {0.2134}
KN01-27-371	4.910 {0.1933}	KN01-27-3C1	5.450 {0.2146}
KN01-27-372	4.940 {0.1945}	KN01-27-3C2	5.480 {0.2157}
KN01-27-373	4.970 {0.1957}	KN01-27-3C3	5.510 {0.2169}
KN01-27-374	5.000 {0.1969}	---	---

**PART LOCATION:****Exhaust manifold (WU-TWC), R&R (For SKYACTIV-G Engines only)**

**CONSUMER NOTICE:** The information and instructions in this bulletin are intended for use by skilled technicians. Mazda technicians utilize the proper tools/equipment and take training to correctly and safely maintain Mazda vehicles. These instructions should not be performed by "do-it-yourselfers." Customers should not assume this bulletin applies to their vehicle or that their vehicle will develop the described concern. To determine if the information applies, customers should contact their nearest authorized Mazda dealership. Mazda North American Operations reserves the right to alter the specifications and contents of this bulletin without obligation or advance notice. All rights reserved. No part of this bulletin may be reproduced in any form or by any means, electronic or mechanical---including photocopying and recording and the use of any kind of information storage and retrieval system ---without permission in writing.

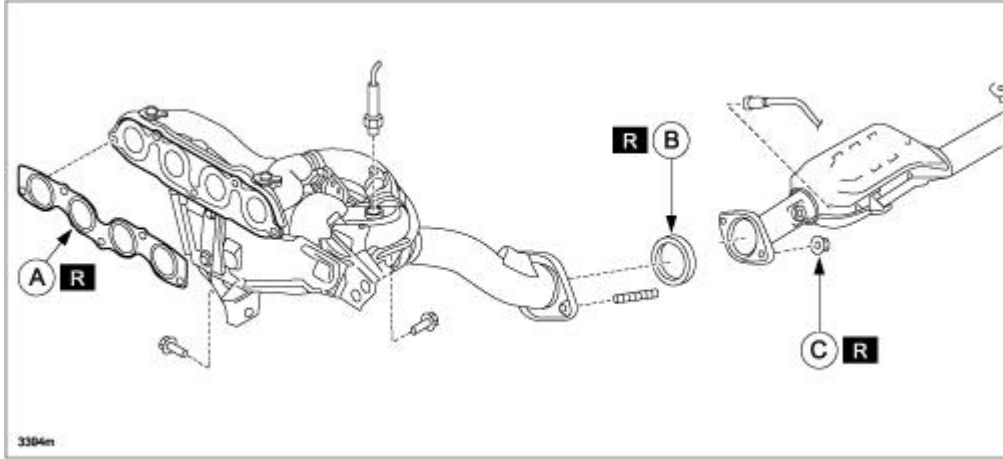

Intermediate Shaft, Disconnect from Steering Gear

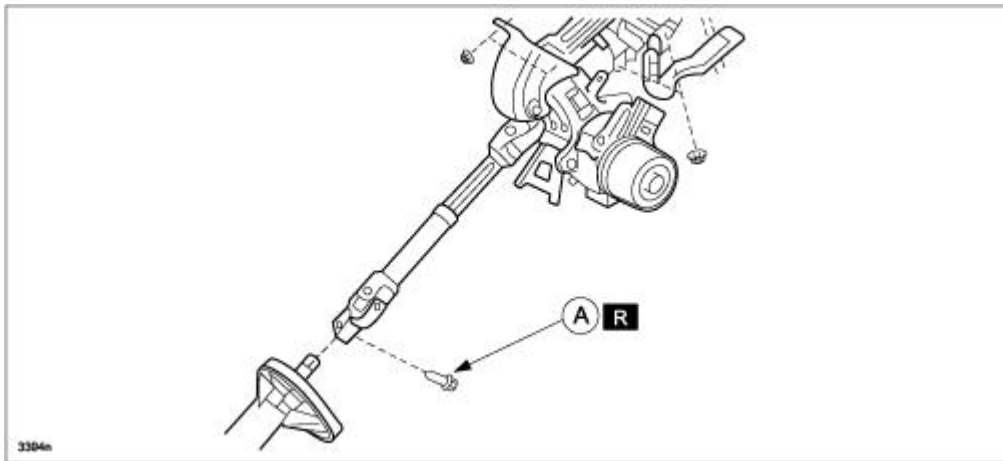

Drive Shaft (RH), R&R

**CONSUMER NOTICE:** The information and instructions in this bulletin are intended for use by skilled technicians. Mazda technicians utilize the proper tools/equipment and take training to correctly and safely maintain Mazda vehicles. These instructions should not be performed by "do-it-yourselfers." Customers should not assume this bulletin applies to their vehicle or that their vehicle will develop the described concern. To determine if the information applies, customers should contact their nearest authorized Mazda dealership. Mazda North American Operations reserves the right to alter the specifications and contents of this bulletin without obligation or advance notice. All rights reserved. No part of this bulletin may be reproduced in any form or by any means, electronic or mechanical---including photocopying and recording and the use of any kind of information storage and retrieval system ---without permission in writing.

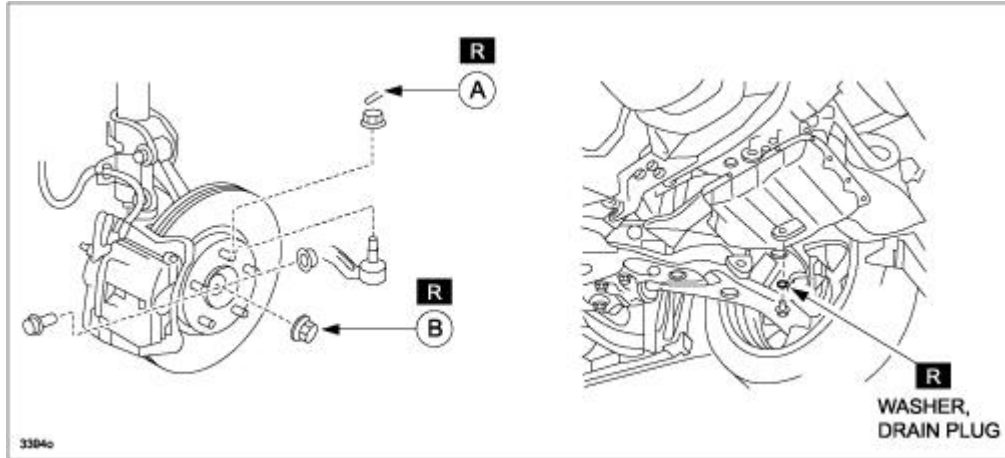

### Transfer, Overhaul

**CONSUMER NOTICE:** The information and instructions in this bulletin are intended for use by skilled technicians. Mazda technicians utilize the proper tools/equipment and take training to correctly and safely maintain Mazda vehicles. These instructions should not be performed by "do-it-yourselfers." Customers should not assume this bulletin applies to their vehicle or that their vehicle will develop the described concern. To determine if the information applies, customers should contact their nearest authorized Mazda dealership. Mazda North American Operations reserves the right to alter the specifications and contents of this bulletin without obligation or advance notice. All rights reserved. No part of this bulletin may be reproduced in any form or by any means, electronic or mechanical---including photocopying and recording and the use of any kind of information storage and retrieval system ---without permission in writing.

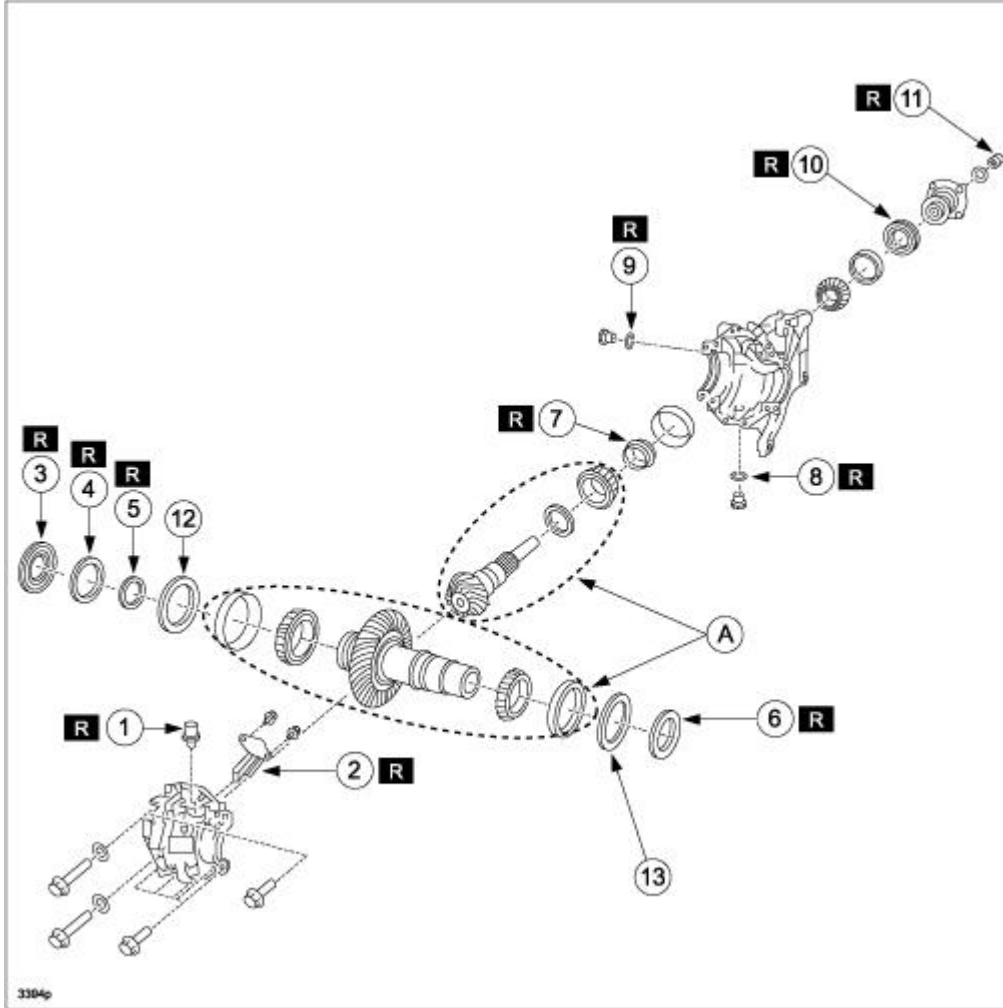

(A) - Do Not disassemble.

	Part Description		Part Description
1	Breather	8	Drain plug, washer
2	Baffle plate	9	Oil level plug, washer
3	Transfer oil seal (RH) No.1	10	Oil seal (Modified)
4	Transfer oil seal (RH) No.2	11	Locknut
5	Transfer oil seal (RH) No.3	12	Adjustment Shim (RH)
6	Transfer oil seal (LH)	13	Adjustment Shim (LH)
7	Collapsible spacer		

**CONSUMER NOTICE:** The information and instructions in this bulletin are intended for use by skilled technicians. Mazda technicians utilize the proper tools/equipment and take training to correctly and safely maintain Mazda vehicles. These instructions should not be performed by "do-it-yourselfers." Customers should not assume this bulletin applies to their vehicle or that their vehicle will develop the described concern. To determine if the information applies, customers should contact their nearest authorized Mazda dealership. Mazda North American Operations reserves the right to alter the specifications and contents of this bulletin without obligation or advance notice. All rights reserved. No part of this bulletin may be reproduced in any form or by any means, electronic or mechanical---including photocopying and recording and the use of any kind of information storage and retrieval system ---without permission in writing.



## WARRANTY INFORMATION

### NOTE:

- This warranty information applies only to verified customer complaints on vehicles eligible for warranty repair.
- This repair will be covered under Mazda's New Vehicle Limited Warranty term.
- Additional diagnostic time cannot be claimed for this repair.

1. When the companion flange oil seal is replaced **without** disassembling the transfer unit.

Warranty Type	A
Symptom Code	76
Damage Code	9C
Part Number Main Cause	KN01-27-165A
Quantity	1
Operation Number / Labor Hours:	TRANSFER UNIT COMPANION FLANGE OIL SEAL (REAR), RR  (Without disassembling Transfer Unit)  XXN95XRX / 1.3 Hrs.

2. When the companion flange oil seal is replaced **with** disassembling the transfer unit.

Warranty Type	A
Symptom Code	76
Damage Code	9C
Part Number Main Cause	KN01-27-165A
Quantity	1

**CONSUMER NOTICE:** The information and instructions in this bulletin are intended for use by skilled technicians. Mazda technicians utilize the proper tools/equipment and take training to correctly and safely maintain Mazda vehicles. These instructions should not be performed by "do-it-yourselfers." Customers should not assume this bulletin applies to their vehicle or that their vehicle will develop the described concern. To determine if the information applies, customers should contact their nearest authorized Mazda dealership. Mazda North American Operations reserves the right to alter the specifications and contents of this bulletin without obligation or advance notice. All rights reserved. No part of this bulletin may be reproduced in any form or by any means, electronic or mechanical---including photocopying and recording and the use of any kind of information storage and retrieval system ---without permission in writing.

Operation Number / Labor Hours:	TRANSFER UNIT COMPANION FLANGE OIL SEAL (REAR), RR (With disassembling Transfer Unit)  XXMC8ARX / 6.0 Hrs. (SKYACTIV-G Engines)
---------------------------------	---

**NOTE:** Enter other replaced parts in Related Part Number reference to "PARTS INFORMATION".

**CONSUMER NOTICE:** The information and instructions in this bulletin are intended for use by skilled technicians. Mazda technicians utilize the proper tools/equipment and take training to correctly and safely maintain Mazda vehicles. These instructions should not be performed by "do-it-yourselfers." Customers should not assume this bulletin applies to their vehicle or that their vehicle will develop the described concern. To determine if the information applies, customers should contact their nearest authorized Mazda dealership. Mazda North American Operations reserves the right to alter the specifications and contents of this bulletin without obligation or advance notice. All rights reserved. No part of this bulletin may be reproduced in any form or by any means, electronic or mechanical---including photocopying and recording and the use of any kind of information storage and retrieval system ---without permission in writing.