

© 2017 Mazda Motor of America, Inc.

Subject: SPECIAL SERVICE TOOL ANNOUNCEMENT- JANUARY 2017	Bulletin No: 00-002/17
	Last Issued: 01/19/2017

APPLICABLE MODEL(S)/VINS

2016-2017 CX-9

DESCRIPTION

In support of the 2016-2017 Mazda CX-9, Mazda will make available a Special Service Tool (SST) to address front suspension noise for specific highly humid and wet climate conditions of the lower Gulf States and Hawaii. The SST will be needed to complete repairs detailed in TSB 02-003/17, and is available through Mazda's tool vendor, Snap-on Tools.

NOTE: For Florida and Hawaii dealers only: The tool will be automatically shipped to your location.

Part Number	Description
49US-16-004	Bushing Remover-Installer

BILLING INFORMATION

Tool(s) will be automatically invoiced to your dealer parts account statement. Current pricing is available on Mazda e-Store. If your accounting department has any questions regarding this invoicing, please call Mazda Special Service Tools (949-442-6539).

SHIPPING INFORMATION

Tool will be available for ordering and shipping to your Service Department starting in January, 2017.

OBTAINING ADDITIONAL TOOLS

To order additional SSTs, submit orders via Mazda e-Store at <http://dealers.mazdausa.com>.

CUSTOMER SERVICE INFORMATION

For warranty or product information call Snap-on Customer Service at (800) 424-7226.

SPECIAL SERVICE TOOL (SST) AND USAGE

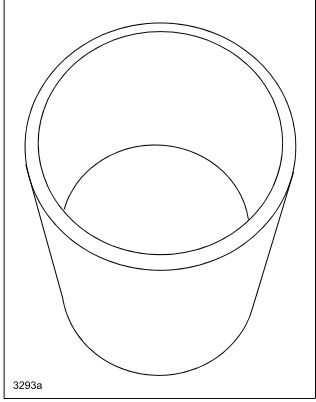
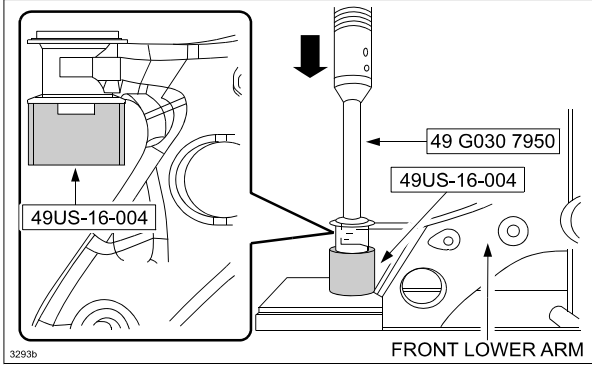
<p>PART NUMBER / NAME: 49B0-25-004 (Bushing Remover-Installer)</p> <p>APPLICABLE MODELS: 2016-2017 CX-9</p> <p>USAGE: Utilized to remove/ install the front control arm bushing for proper noise free operation of the front suspension.</p>	<p>OVERVIEW</p>  <p>3293a</p>	<p>USAGE</p>  <p>49 G030 7950</p> <p>49US-16-004</p> <p>FRONT LOWER ARM</p> <p>3293b</p>
---	---	---