



Service Advisory

Published for Polaris Dealerships, Distributors, and Service Technicians

Division: On Road

Article: VSA-15-01 A-D

Date: July 15, 2015

EXPIRATION DATE: July 15, 2017

SUBJECT:

2010-2015 Victory Cross Country / Cross Roads / Magnum / Hard-Ball – Saddlebag Lock Wear

PURPOSE:

Victory Motorcycle has learned that a potential issue may exist in some 2010-2015 Victory Cross Country / Cross Roads / Magnum / Hard-Ball saddlebag lock assemblies. This Service Advisory has been released to communicate a process which enables dealers to assist customers and repair qualified motorcycles without requiring pre-authorization from Victory Motorcycle.

- The saddlebag lock housing may not properly align with the corresponding lock hoop, resulting in premature wear and an increased potential for saddlebag lock failure.

SERVICE ADVISORY DETAILS:

- This program provides extended warranty coverage for saddlebag lock assemblies on affected Victory models, as defined by this communication.
- This program provides parts and labor coverage for 2 years following the release date of this Service Advisory, for saddlebags that exhibit this concern.
- Extended coverage only applies to Victory motorcycles equipped with factory hard saddlebags.
- The motorcycle must be registered to the current owner. If a subsequent owner is requesting coverage, the warranty must be transferred by the dealership prior to completing the work and submitting the warranty claim. Work completed without transferring ownership will be charged back.

POTENTIALLY AFFECTED MODELS:

2010-2015 Victory Cross Country, Cross Roads, Hard-Ball and Magnum motorcycles equipped with Victory hard saddlebags.

CUSTOMER NOTIFICATION:

Dealers **should not** contact customers regarding this Service Advisory. Victory has issued a consumer letter to owners of affected motorcycles explaining how to inspect saddlebag locks, and describing the terms of the extended warranty coverage.

WARRANTY CLAIM INFORMATION:

A Wholegood Stock (WS) or Standard (ST) warranty claim may be submitted listing the complete (17 digit) Vehicle Identification Number. Vehicles that are out of the factory warranty period (OW) should use Service Advisory number(s) for the Authorization Code (see REPAIR INFORMATION for details).

REPAIR INFORMATION:

1. Upon consumer request ONLY, perform the SADDLEBAG LOCK INSPECTION outlined in this Service Advisory to determine which parts are required to complete the repair.
2. Install the Lock Alignment Kit (2881595) into the right side saddlebag. **All right side saddlebag lock inspections receive the Lock Alignment Kit regardless of wear.**
3. Complete the necessary repair(s) as outlined in this Service Advisory.
4. File a warranty claim using the appropriate AUTHORIZATION CODE following completion.

WARRANTY CLAIM PROCESSING INSTRUCTIONS:

1. "Start a New Warranty Claim" for the affected VIN.
2. Enter labor time for the repair(s) performed. 12 minutes of labor for one side / 24 minutes of labor for both sides.
3. Use fail codes: 140 / 268 / 135
4. Use part number 2881595 as the primary fail part.
5. Enter the **Service Advisory number** in the AUTHORIZATION field.
6. Enter: "Saddlebag Lock Advisory" in the CONCERN field. Enter: "Defective Saddlebag Lock" in the CAUSE field.
Enter: "Repaired Saddlebag Lock" in the CORRECTION field.
7. Save and submit the claim to Victory Motorcycles.

NOTE: This claim will not process without following the instructions above!

VSA-15-01A – INSTALL ALIGNMENT KIT (RIGHT SIDE BAG)

CLAIM TYPE	Wholegood Stock (WS), Standard (ST) or Out of Warranty (OW)
LABOR ALLOWANCE	12 Minutes (0.2 hours)
PART NUMBER / DESCRIPTION	2881595 (QTY.1) – Lock Alignment Kit
AUTHORIZATION CODE	VSA-15-01A
SERVICE ADVISORY EXPIRATION DATE	Service Advisory VSA-15-01A expires July 15, 2017. Victory will not provide coverage for saddlebag lock repair after the expiration date has passed.

VSA-15-01B – INSTALL ALIGNMENT KIT, LOCK HOUSING & HOOP (RIGHT SIDE BAG)

CLAIM TYPE	Wholegood Stock (WS), Standard (ST) or Out of Warranty (OW)
LABOR ALLOWANCE	12 Minutes (0.2 hours)
PART NUMBER / DESCRIPTION	2881595 (QTY.1) – Lock Alignment Kit 7082111 (QTY.1) – Housing Kit 5335316 (QTY.1) – Hoop, Latch Striker
AUTHORIZATION CODE	VSA-15-01B
SERVICE ADVISORY EXPIRATION DATE	Service Advisory VSA-15-01B expires July 15, 2017. Victory will not provide coverage for saddlebag lock repair after the expiration date has passed.

VSA-15-01C – INSTALL ALIGNMENT KIT (LEFT SIDE BAG)

CLAIM TYPE	Wholegood Stock (WS), Standard (ST) or Out of Warranty (OW)
LABOR ALLOWANCE	12 Minutes (0.2 hours)
PART NUMBER / DESCRIPTION	2881595 (QTY.1) – Lock Alignment Kit
AUTHORIZATION CODE	VSA-15-01C
SERVICE ADVISORY EXPIRATION DATE	Service Advisory VSA-15-01C expires July 15, 2017. Victory will not provide coverage for saddlebag lock repair after the expiration date has passed.

VSA-15-01D – INSTALL ALIGNMENT KIT, LOCK HOUSING & HOOP (LEFT SIDE BAG)

CLAIM TYPE	Wholegood Stock (WS), Standard (ST) or Out of Warranty (OW)
LABOR ALLOWANCE	12 Minutes (0.2 hours)
PART NUMBER / DESCRIPTION	2881595 (QTY.1) – Lock Alignment Kit 7082111 (QTY.1) – Housing Kit 5335316 (QTY.1) – Hoop, Latch Striker
AUTHORIZATION CODE	VSA-15-01D
SERVICE ADVISORY EXPIRATION DATE	Service Advisory VSA-15-01D expires July 15, 2017. Victory will not provide coverage for saddlebag lock repair after the expiration date has passed.

PARTS RETURN OR DISPOSAL INFORMATION:

All failed parts, including the RO, must be returned to Victory for inspection and failure verification. A copy of the repair order with the customer's information, signature, repair work information, and vehicle mileage, etc. must also be returned with the parts. Dealerships will be charged back if parts and repair order are not received within 30 days of the claim date. Dealerships will be charged back for all non-defective part(s) returned to Victory.

Sincerely,



Doug Koch
Technical Service and Warranty Manager

SADDLEBAG LOCK INSPECTION:

NOTE: Saddlebag wear is known to occur primarily in the RIGHT SIDE saddlebag lock housing. Although unlikely, wear may also occur in the LEFT SIDE saddlebag lock, so it must also be inspected as outlined below.

1. Park the motorcycle on a flat surface and rest securely on the side stand.
2. Open the right side saddlebag lid and locate the lock assembly ①.
3. Inspect the lock housing guide area shown in FIGURE 1.

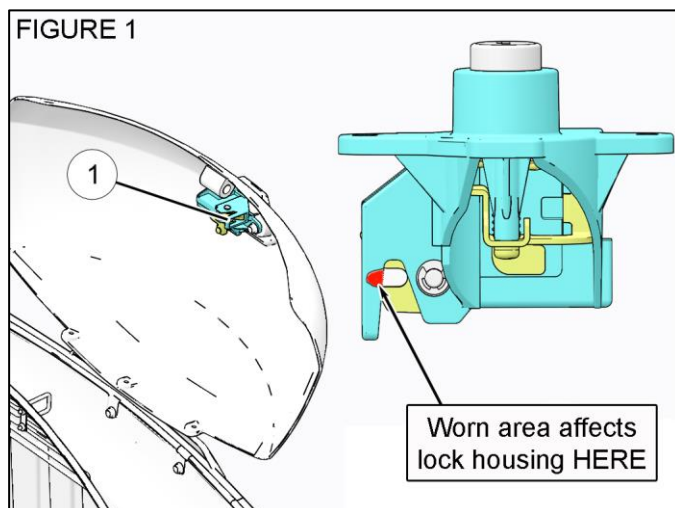

4. Verify that the lock housing guide has a straight edge as shown in FIGURE 2, and that wear has not caused the lock housing guide to become distorted.

NOTE: If excessive wear is found, replace the lock housing and the hoop.

SPECIFICATION:

Lock housing guide should not have an indentation exceeding **0.5 mm** where it contacts the lock hoop while in the closed position. **Scuffs and scratches should be considered normal wear.**

5. Repeat steps 2-4 for the left side saddlebag.
6. If lock housings are **not worn**, install an ALIGNMENT KIT in the right bag and file a claim for VSA-15-01A.
7. If a lock housing is **worn**, proceed to LOCK HOUSING REPLACEMENT

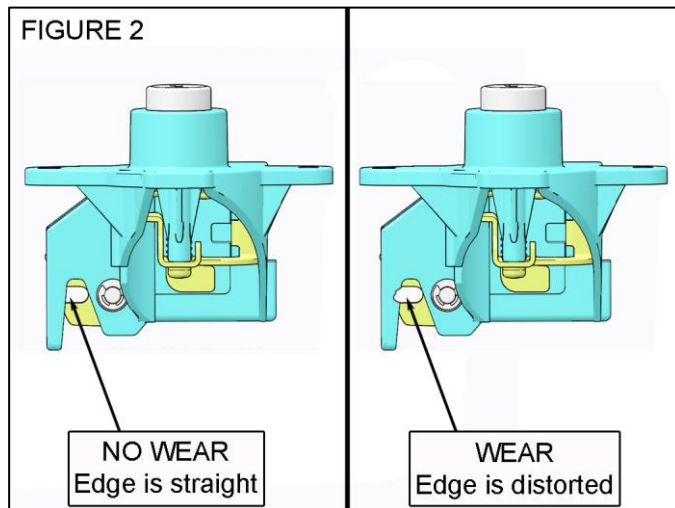

ALIGNMENT KIT INSTALLATION (2881595 – Lock Alignment Kit):

1. Remove lock and handle from saddlebag lid by removing M6 fasteners ①. Discard fasteners.

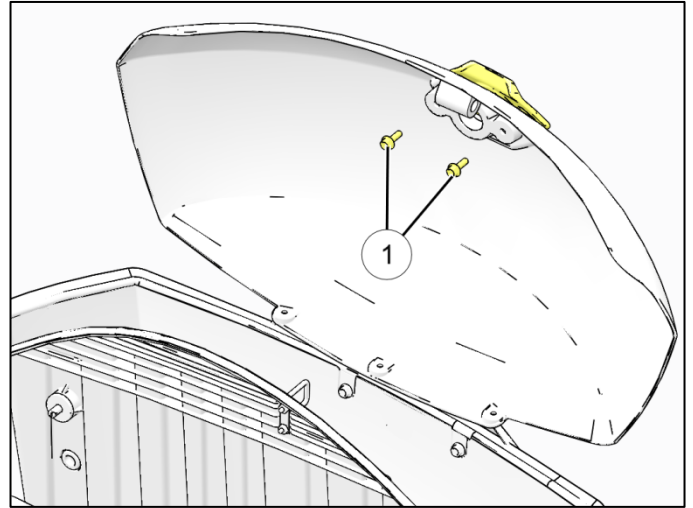

2. Using 3mm hex drive, remove lock hoop ② from saddlebag. Keep fasteners ③ and nut plate ④ for installation of hoop.
3. Remove saddlebag from bike and place it on a blanket or other soft surface to prevent cosmetic damage.

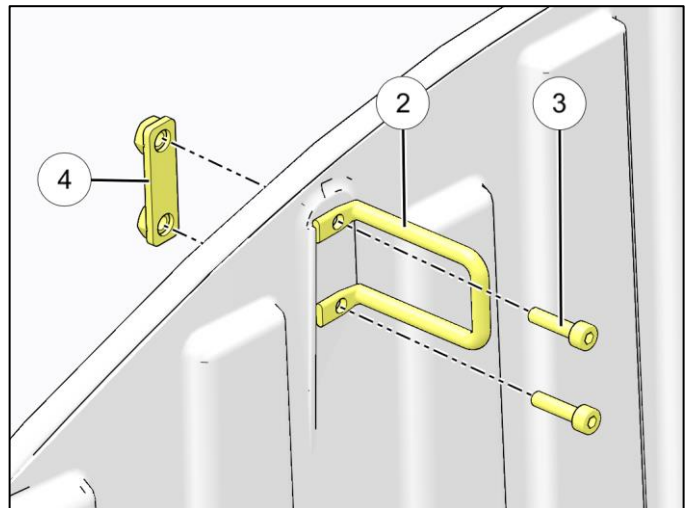

4. Drill hoop mounting holes ⑤ in saddlebag bin using 1/4" drill bit. Reinstall saddlebag onto bike.

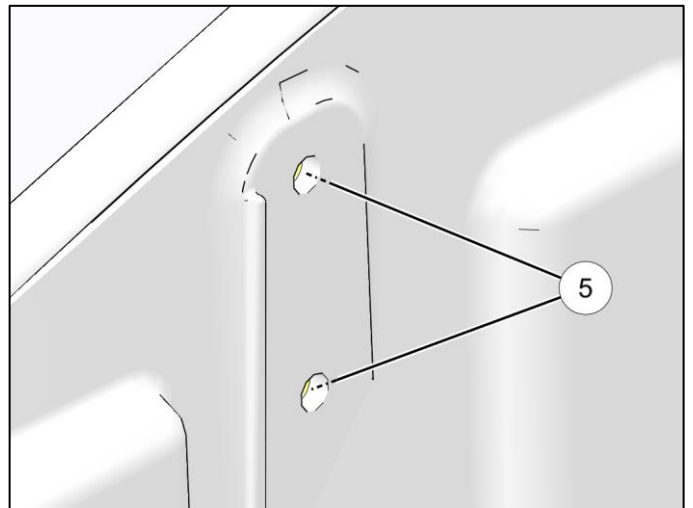

5. Install hoop ⑥ using removed bolts and nut plate. Loosely install fasteners, biasing the hoop and nut plate toward the front of the bike for right hand saddlebag installation. Bias the hoop and nut plate toward the rear of the bike for left hand saddlebag installation. See images below.
6. Torque fasteners to specification.

TORQUE:

Saddlebag Lock Hoop: **43 in-lbs (4.8 Nm)**

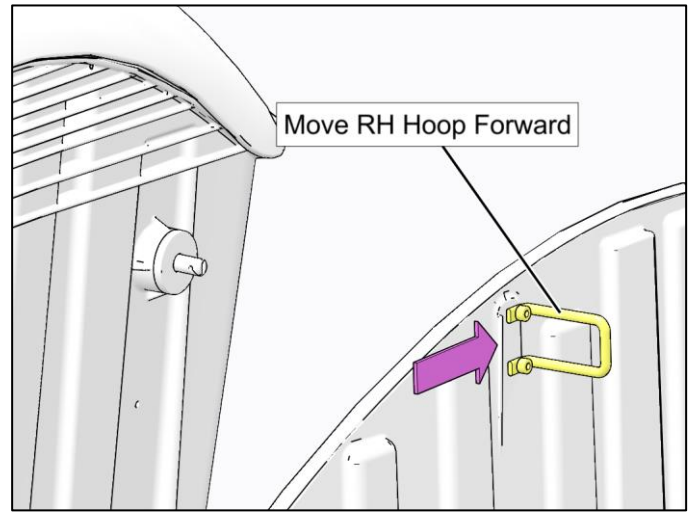
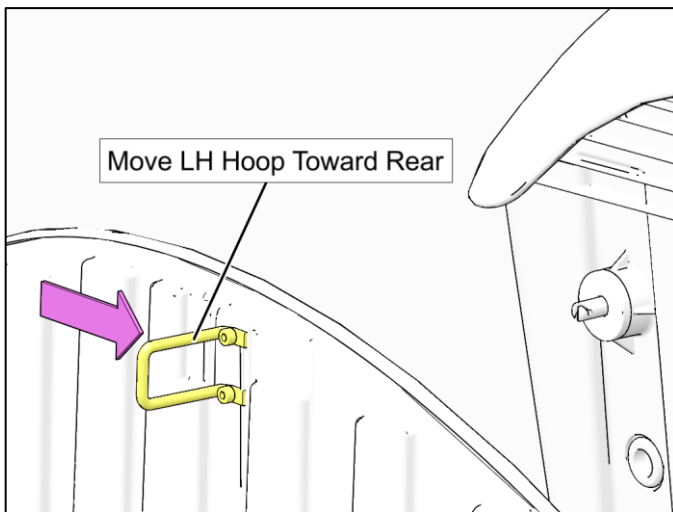
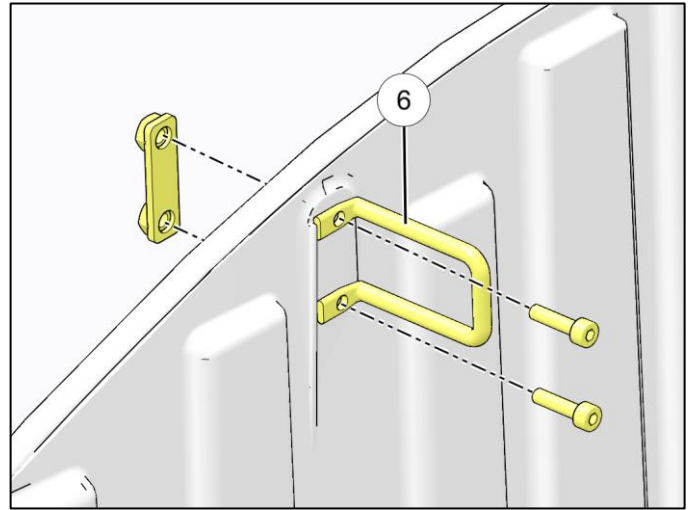

7. Remove foam bumper ⑦ from lid. Ensure adhesive tape from bumper is removed from lid.

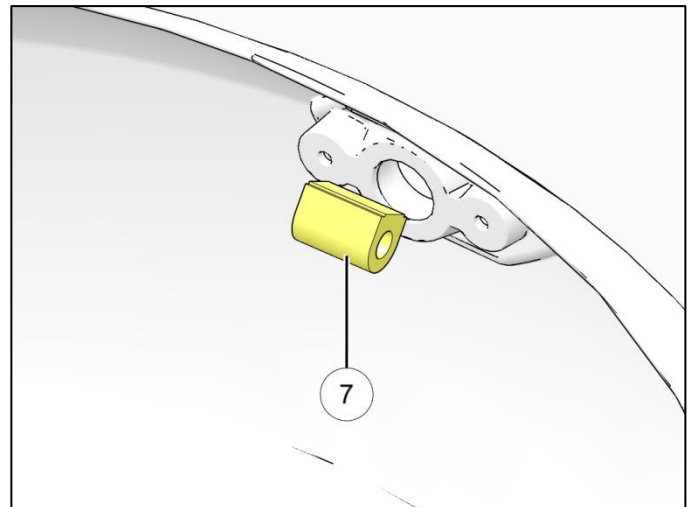

8. Remove rubber seal from latch housing and discard. Install thicker foam seal (8) from kit onto latch.
9. Run new M6 fasteners through mounting holes on the latch. Slide 2 plastic washers (9) from kit onto fastener as shown.
10. Position latch onto lid with plastic washers between latch and lid. With lid handle in place, hand-start M6 fasteners. Tighten the fastener without the washers first, next tighten the fastener with the washers. Torque both fasteners to specification. 84 in-lbs.

TORQUE:

Saddlebag Lock: **84 in-lbs (9.5 Nm)**

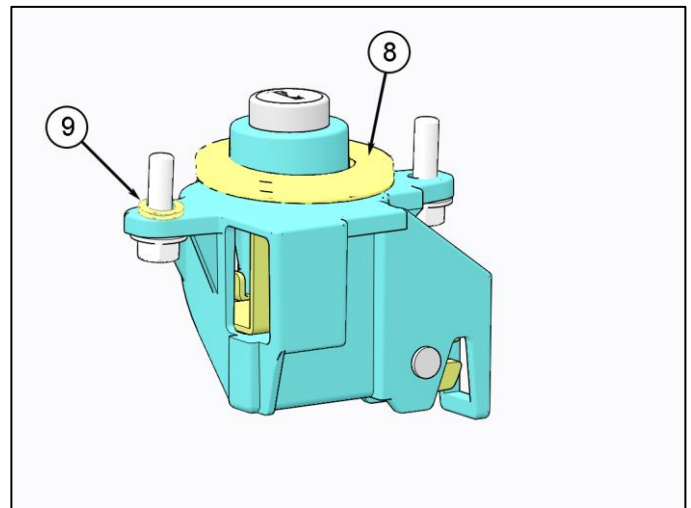

11. Close lid and check for binding or interference between latch and hoop. If no issues, proceed to step 13.
12. If the lid is not closing properly due to binding or interference between latch and hoop, remove latch and handle by removing M6 fasteners. Reinstall latch using 1 plastic washer instead of 2. Test closing the lid. If latch is once again interfering with the hoop, reinstall latch without any washers.
13. After latch has been aligned successfully, remove adhesive liner from bumper and install as shown. Note that bumper location is different when saddlebag audio is installed.



Bumper location
(without saddlebag audio)



Bumper location
(with saddlebag audio)

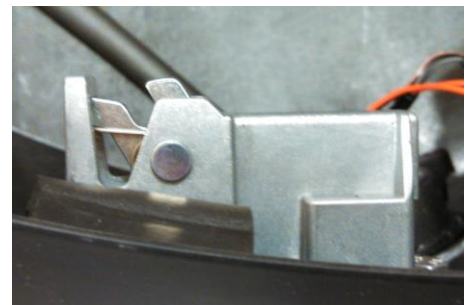

LOCK HOUSING / HOOP REPLACEMENT (7082111 – Housing Kit / 5335316 – Hoop):

IMPORTANT: If needed, the lock housing and lock hoop should be replaced together along with the alignment kit. Refer to the **ALIGNMENT KIT INSTALLATION** instructions for lock hoop replacement.

1. Remove screw ① from the lock assembly.

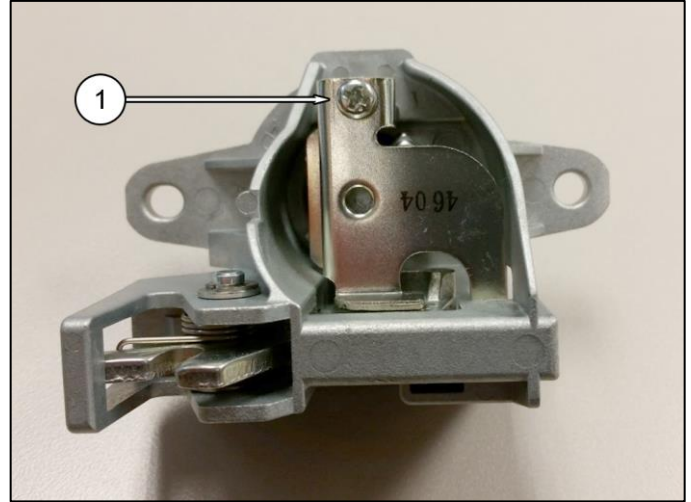

2. Remove the following components and retain for reuse during assembly:

- Bracket
- Pivot
- Spring
- Lock
- O-Ring
- Screw

3. Discard the lock housing.

4. Apply a light coating of all-purpose grease to o-ring.

5. Install the o-ring and lock ② into the new latch housing as shown.

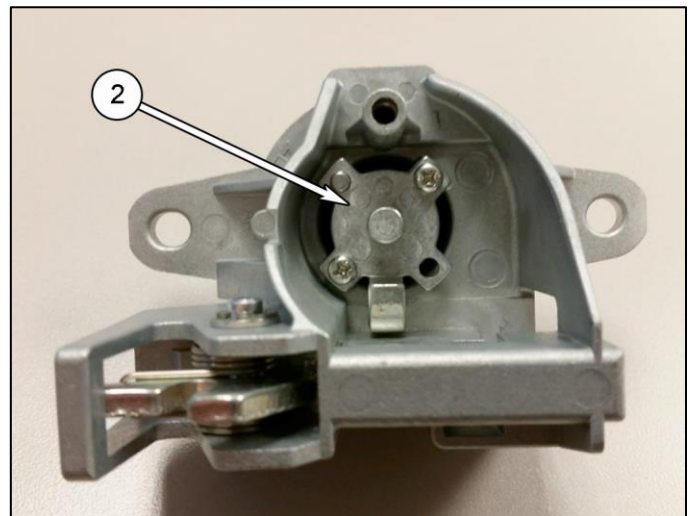
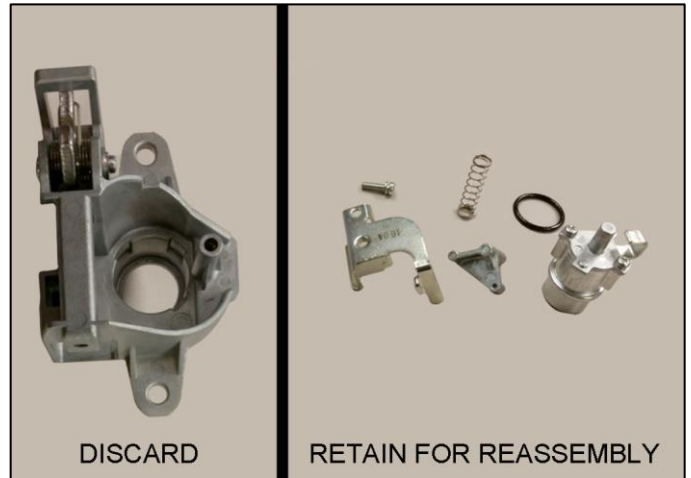

6. Install the pivot ③ as shown.

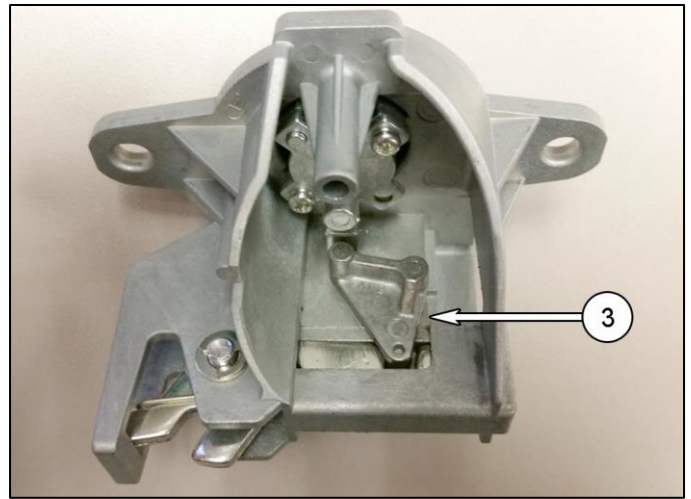

7. Install the spring and bracket, making sure that the spring is engaged in the locating feature ④ on the bracket.

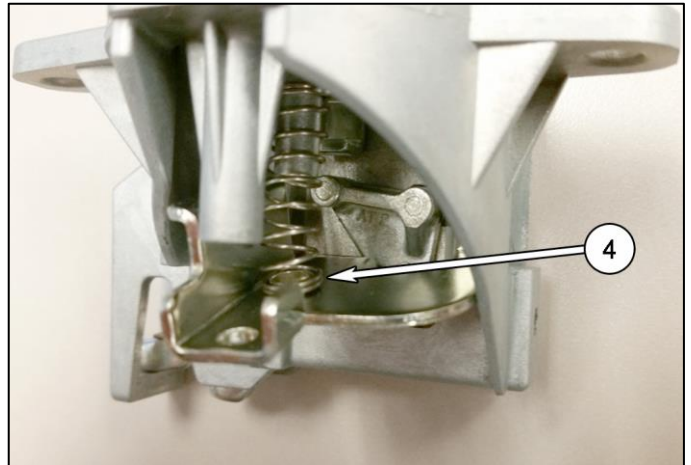

8. Install the screw ⑤ and torque to specification.

TORQUE

Lock Bracket Screw: 14 in-lbs (1.6 Nm)

9. Refer to the **ALIGNMENT KIT INSTALLATION** instructions outlined in this advisory, and install the lock assembly, lock hoop and alignment kit into the affected saddle bag lid.

10. Verify proper latch / lock operation.

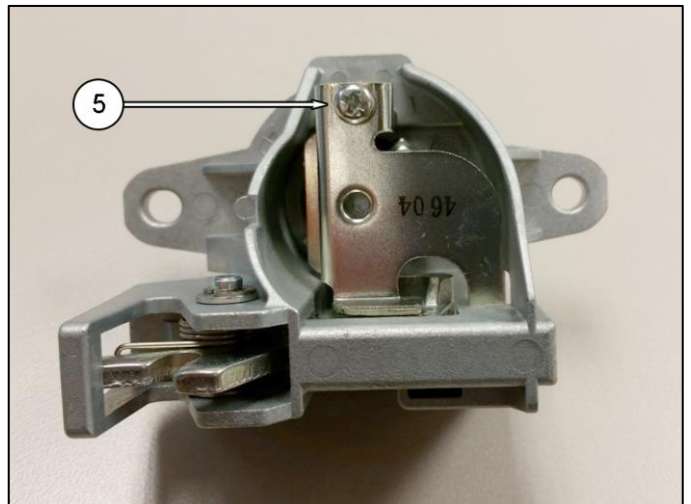



EXAMPLE OF CONSUMER LETTER

Victory Motorcycle Division
Polaris Industries Inc.
P.O. Box 47700
Medina, MN 55340-9960

Dear Victory Owner:

Safety and quality are the highest priorities for Victory Motorcycles. We are sending this letter to notify you of a potential quality issue in some 2010-2015 Cross Country, Cross Roads, Magnum and Hard-Ball motorcycles equipped with Victory hard saddlebags. During assembly, the saddlebag lid lock may have been installed in a position that does not align with the corresponding lock hoop. If the saddlebag lock does not properly align with the hoop, there is an increased potential for premature wear and saddlebag lock failure.

To ensure that we continue to deliver world class product support and address this potential quality issue, Victory has released VSA-15-01 to extend warranty coverage for affected saddlebag locks until July 15, 2017. This program will provide parts and labor coverage for saddlebag lock assemblies on affected Victory models, as defined by this communication.

While this concern will only affect a small number of saddlebags, we encourage riders with higher mileage bikes to inspect the saddlebag lock assembly as shown on the back side of this letter for visible wear. **It is important to note that, saddlebag lock wear is known to occur primarily in the RIGHT SIDE saddlebag.**

Please read and follow the instructions provided on the back side of this letter to determine if your saddlebag lock shows signs of wear. If your saddlebag lock is worn, please contact your authorized Victory dealer and make arrangements to have the lock(s) evaluated and, if necessary, replaced at no cost to you.

If you have questions or if you need more information:

While your Victory dealer is in the best position to answer your questions, if you have any questions that your dealer cannot address, or if you need assistance finding a Victory dealer, please visit the Victory Motorcycle web site at www.victorymotorcycles.com or contact our Victory Consumer Service Department by calling 1-877-737-7172.

This notice was mailed to you according to our most current registration information. If you no longer own your Victory motorcycle, please contact your local Victory dealer to have the ownership information changed. The Victory Consumer Service Department cannot change ownership information without identification.

If you have had this repair performed before you received this letter, you may be eligible to receive reimbursement for the cost of obtaining a pre-notification remedy of the problem associated with this recall. For more information regarding reimbursement please contact your Victory dealer or the Victory Consumer Service Department using the information above.

Thank you for your continued support.

Sincerely,

Victory Motorcycles

SADDLEBAG LOCK INSPECTION:

NOTE: Saddlebag wear is known to occur primarily in the RIGHT SIDE saddlebag lock housing and lock hoop. Although unlikely, wear may also occur in the LEFT SIDE saddlebag lock, so it must also be inspected as outlined below.

1. Park the motorcycle on a flat surface and rest securely on the side stand.
2. Open the right side saddlebag lid and locate the lock assembly ①.
3. Inspect the lock housing guide area shown in FIGURE 1.

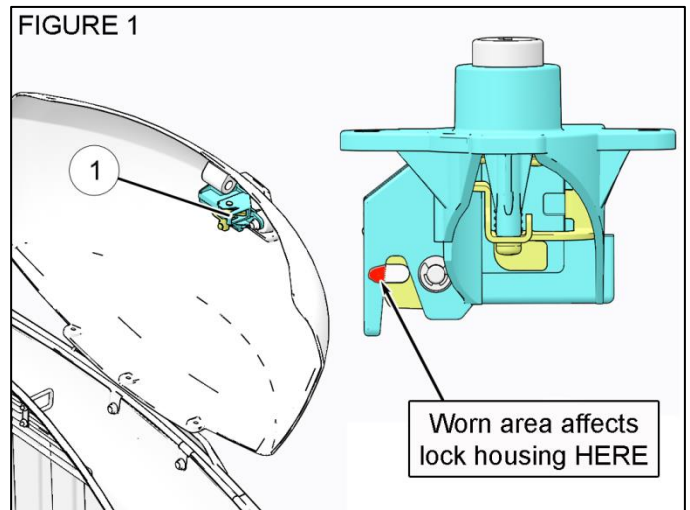

4. Verify that the lock housing guide has a straight edge as shown in FIGURE 2, and that wear has not caused the lock housing guide to become distorted.

SPECIFICATION:

Lock housing guide should not have a visible indentation where it contacts the lock hoop while in the closed position. **Scuffs and scratches should be considered normal wear.**

5. Repeat steps 2-4 for the left side saddlebag.
6. If the lock housing is **not worn**, no further action is required and you may continue to use your motorcycle.
7. If the lock housing is **worn**, please contact your authorized Victory dealer and make arrangements to have the lock(s) evaluated and, if necessary, replaced at no cost to you.

