



# Technical Journal

TITLE:

**Rear door, water intrusion**

<b>REF NO:</b> TJ 31542.1.1	<b>ISSUING DEPARTMENT:</b> Technical Service	<b>CAR MARKET:</b> United States and Canada	
<b>PARTNER:</b> 3 US 7510 Volvo Car USA		<b>ISSUE DATE:</b> 2017-01-05	<b>STATUS DATE:</b> 2017-01-10
<b>FUNC GROUP:</b> 8400	<b>FUNC DESC:</b> Outside trim parts, glass, sealing mould	Page 1 of 7	

“Right first time in Time”

## Attachment

File Name	File Size
TJ 31542.pdf	1.1025 MB

## Vehicle Type

Type	Eng	Eng Desc	Sales	Body	Gear	Steer	Model Year	Plant	Chassis range	Struc Week Range
256							2016-2017		0000561-0123421	201505-201628

## CSC Customer Symptom Codes

Code	Description
R2	Doors/Water leakage/Rear side door

## VST Operation Number

VST Operation Number	Description
98630-2	Scraper moulding side door adjust acc. to TJ31542

## DTC Diagnostic Trouble Codes

Rows beginning with \* are modified

Note! If using a printed copy of this Technical Journal, first check for the latest online version.

## Text

**DESCRIPTION:**

\*Updated structure week.

Water may accumulate on the rear door sill. Water may come out of the lower edge of the rear doors when opening the rear doors.

**SERVICE:**

Please follow attached service instructions.

**VEHICLE REPORT:**

Yes, please submit a Vehicle Report if the service solution described in this TJ has no effect. Use concern area "Vehicle Report" and sub concern area "Support not needed", use function group 8400.

**To view TJ attachment continue to next page. This TJ has one attachment.**



## Volvo Car Customer Service

TJ 31542

<b>Title</b>	Weatherstrip, door window, rear	<b>Page</b>	1 ( 5 )
<b>Action</b>	Adjustment	<b>Operation number:</b>	98630-2

### Affected vehicles

Model year	Model
2016, 2017	XC90

## Color symbols

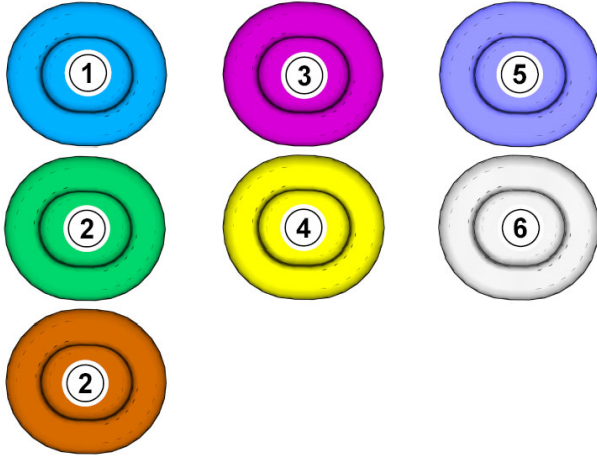

**Note! This colour chart displays (in colour print and electronic version) the importance of the different colours used in the images of the method steps.**

- 1 . Used for focused component, the component with which you will do something.
- 2 . Used as extra colors when you need to show or differentiate additional parts.
- 3 . Used for attachments that are to be removed/installed. May be screws, clips, connectors, etc.
- 4 . Used when the component is not fully removed from the vehicle but only hung to the side.
- 5 . Used for standard tools and special tools.
- 6 . Used as background color for vehicle components.

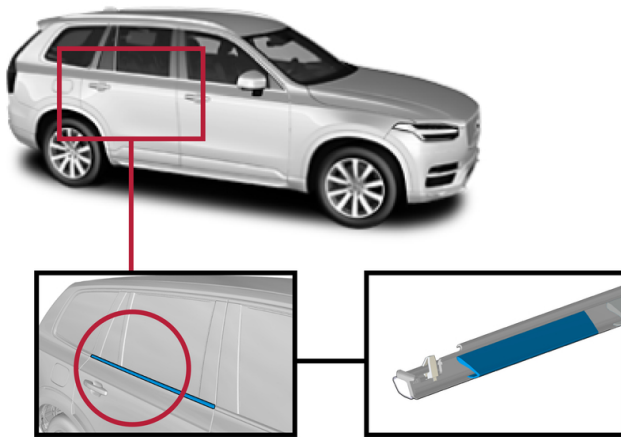

### Removal

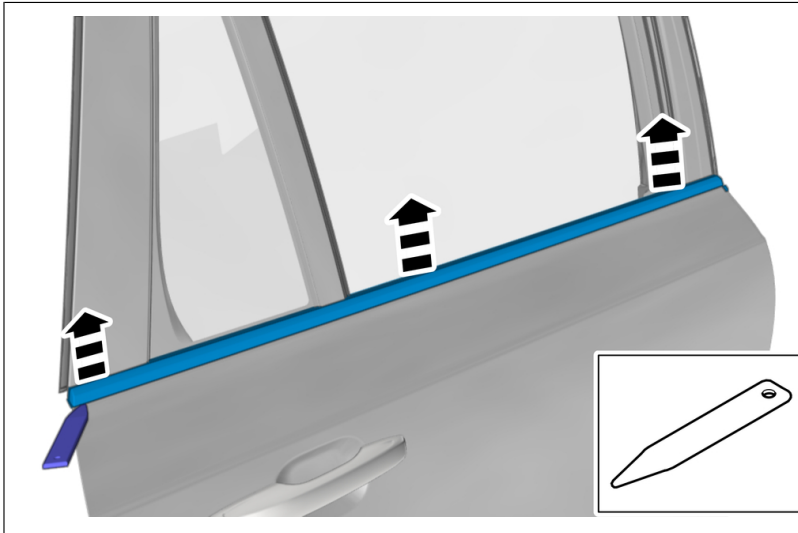

**Caution! Make sure that the component is not bent.**

Remove the marked part.  
On both sides.

### Installation

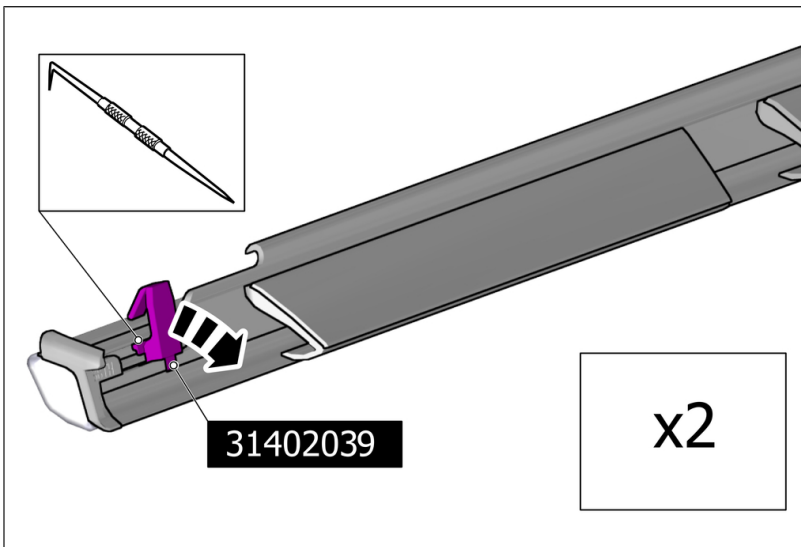

Make sure to replace the marked component with a new.

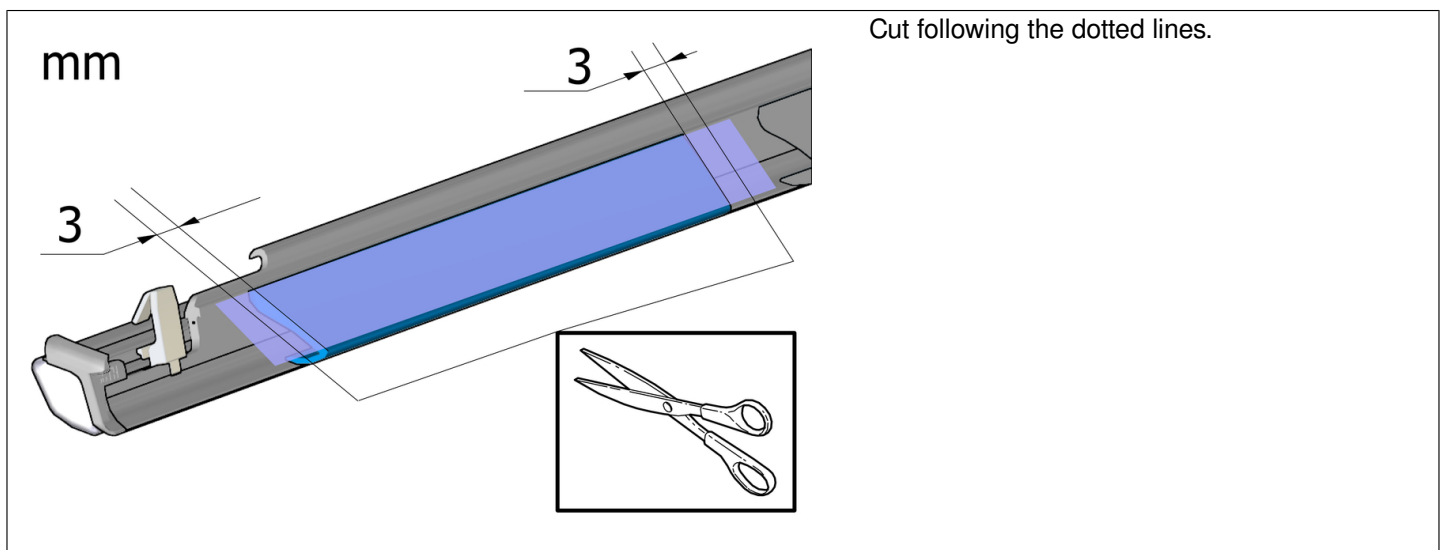
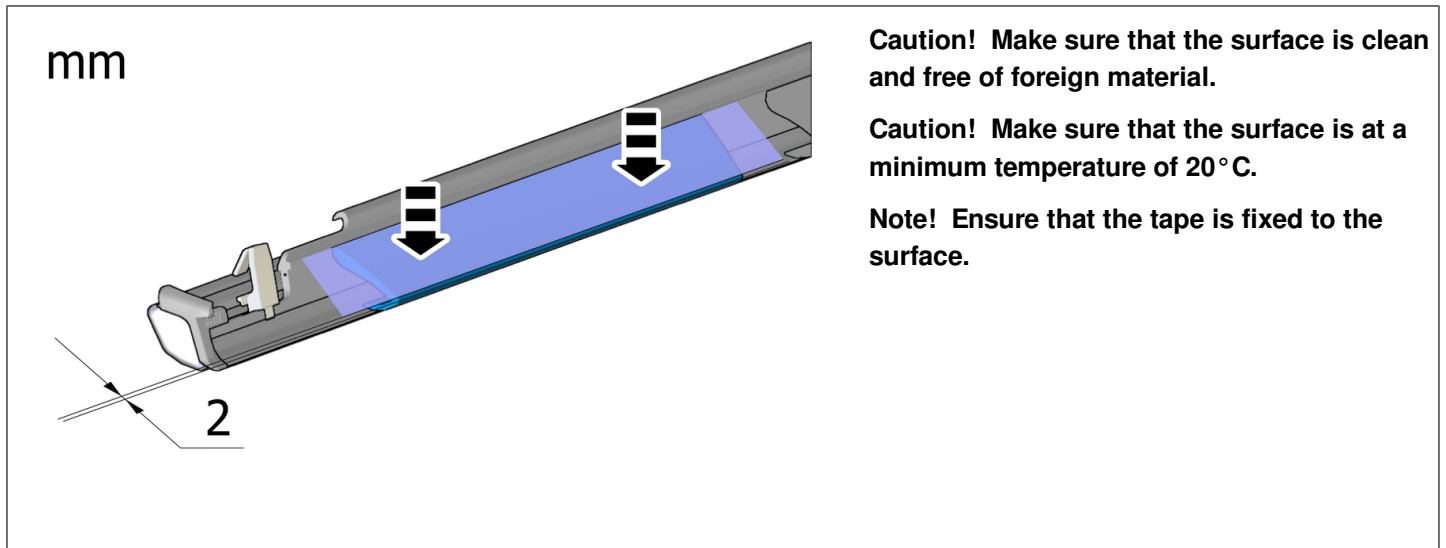
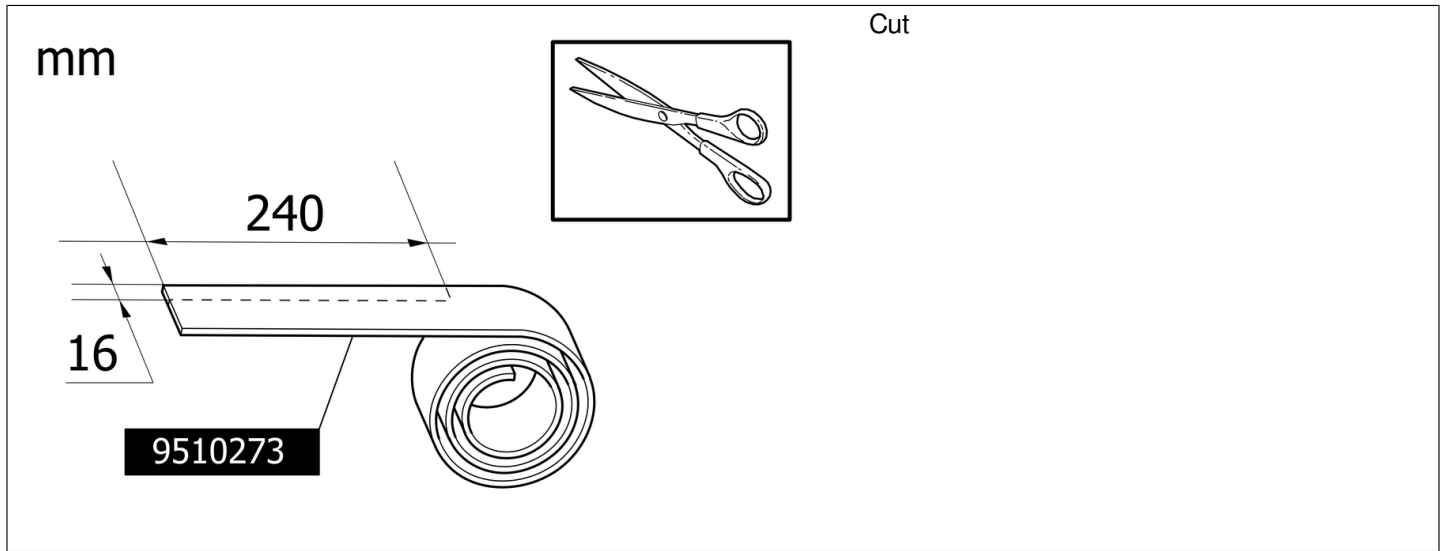

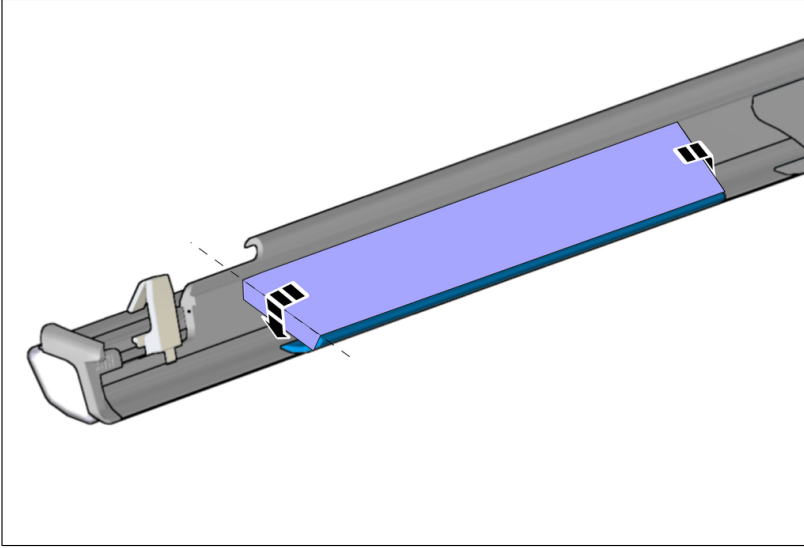

**Note!** Make sure that the tape has not detached from the edges of the component.

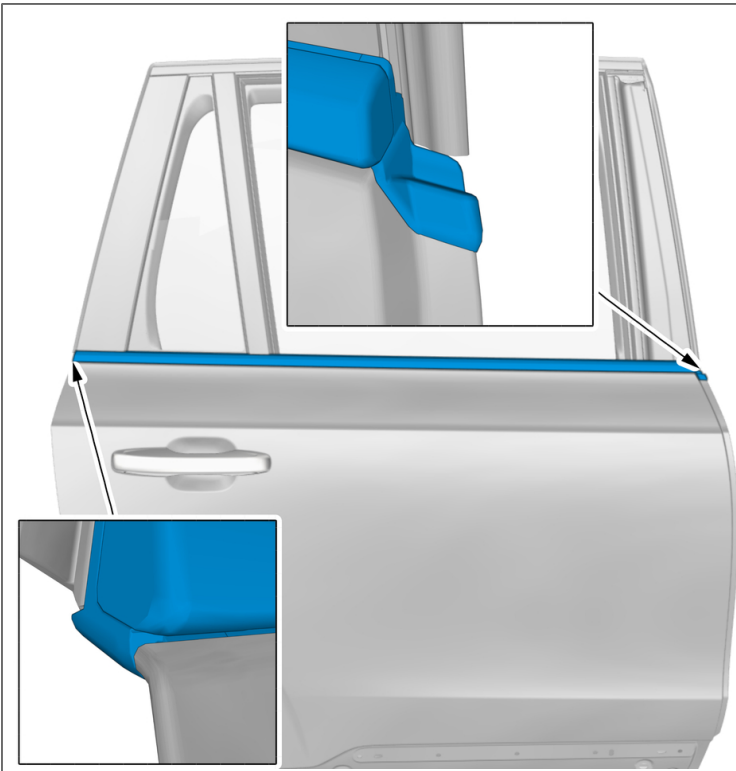

**Caution!** Take extra care when handling the component.