



# Service Bulletin

File in Section: -

Bulletin No.: 16-NA-405

Date: September, 2017

## TECHNICAL

**Subject:** Poor Engine Performance in Extremely Cold Weather Conditions, PCV Bypass Hose and Charge Air Cooler Icing, Malfunction Indicator Lamp (MIL) Illuminated - DTC P0299, P0236, P2227, P00C7 Set

**Attention:** For vehicles that are out of warranty, refer to Special Coverage #17157.

Brand:	Model:	Model Year:		VIN:		Engine:	Transmission:
		from	to	from	to		
Buick	Encore	2013	2017			1.4L (LUV)	
Chevrolet	Trax						

<b>Involved Region or Country</b>	North America
<b>Condition</b>	<p>Some customers may comment that when driving short distances and/or slow speed driving cycles, their vehicle experiences one or several of the following conditions within the first 10 to 15 minutes of vehicle operation in extremely cold weather conditions (-18°C or less / 0°F or less):</p> <ul style="list-style-type: none"> <li>• Loss of power.</li> <li>• Smoke out the tail pipe.</li> <li>• Hesitation on acceleration.</li> <li>• Stalling condition.</li> <li>• Burning oil odor possibly caused by oil leak.</li> <li>• May also notice a Malfunction Indicator Lamp illuminated.</li> <li>• After driving for a period of time, the driveability issues seem to diminish.</li> <li>• Malfunction Indicator Light Illuminated.</li> </ul> <p>This condition may also cause an increase in crankcase pressure, creating oil leaks at seals and gaskets.</p> <p>The technician may find one or more of the following DTCs set:</p> <ul style="list-style-type: none"> <li>• P0299</li> <li>• P0236</li> <li>• P2227</li> <li>• P00C7</li> </ul>
<b>Cause</b>	<p>This condition may be caused by one or more of the following:</p> <ul style="list-style-type: none"> <li>• Plugged Crank Case Vent tube from ice forming in the tube during very cold weather conditions.</li> <li>• Ice accumulation in the charge air cooler restricting air flow to the throttle body.</li> </ul>
<b>Correction</b>	<p><b>Important:</b> The PCV heater parts are only to be used in northern states or provinces that temperatures are -18°C or less / 0°F or less and for critical customers only.</p> <p>If any of the following conditions are validated to be caused by freezing/icing, installation of the following components are necessary:</p> <ul style="list-style-type: none"> <li>• Heated PCV Bypass system</li> <li>• Modified Charge Air Cooler (CAC)</li> </ul> <p>An oil change is necessary to remove any moisture from the engine.</p>

**Important:** If a fascia blocker was installed on the vehicle, it must be removed and discarded. A new fascia blocker will no longer need to be installed on the vehicle.

## PCV Heater Service Procedure

**Notice:** The PCV Heater may have been installed previously onto the vehicle. If the PCV heater has been installed, proceed to step 31.

1. Remove the battery. Refer to *Battery Replacement* in SI.
2. Remove engine cover.

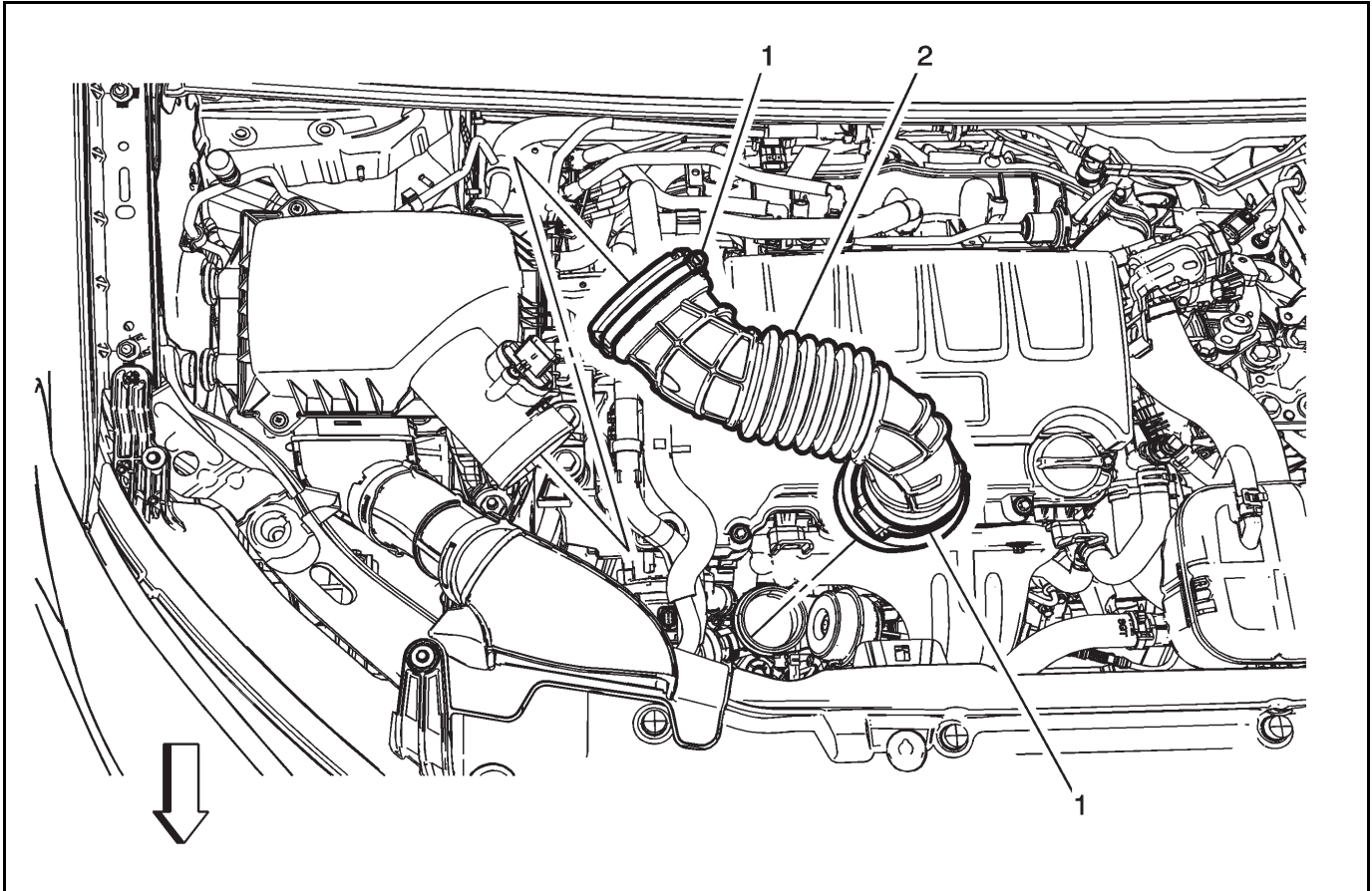

3. Remove and discard the air cleaner outlet duct (2) and resonator assembly.

**Caution:** Do NOT remove the vacuum hose from the vehicle unless the vacuum hose shows apparent signs of damage. Part damage may occur when attempting to disconnect the vacuum hose.

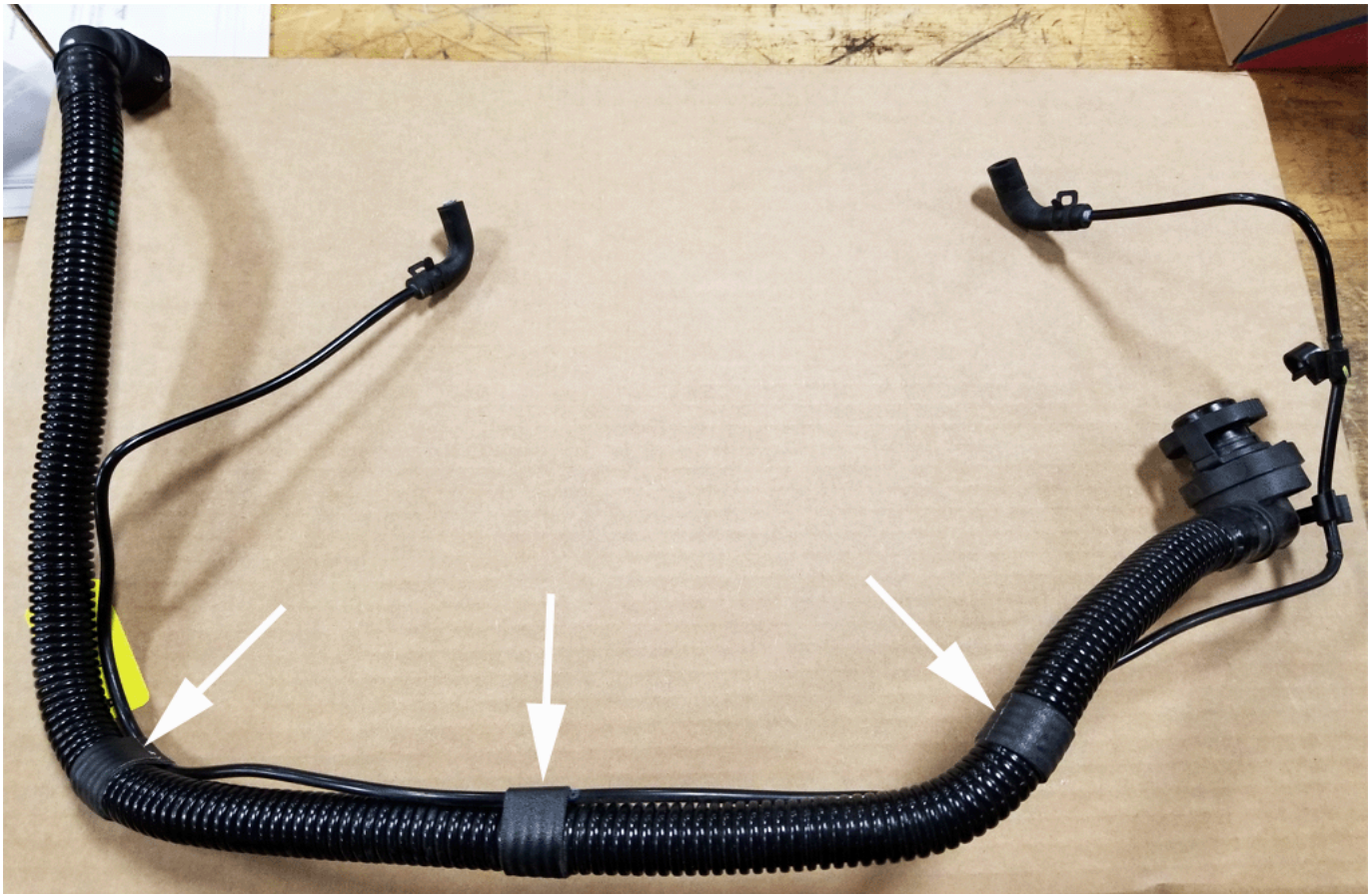

4855374

4. Using care, cut and remove the tape that secures the vacuum line to the Positive Crankcase Ventilation (PCV) Hose/Pipe/Tube.

5. Remove and discard the PCV Hose/Pipe/Tube (1) leaving the vacuum line. Refer to *Positive Crankcase Ventilation Hose/Pipe/Tube Replacement* in SI.

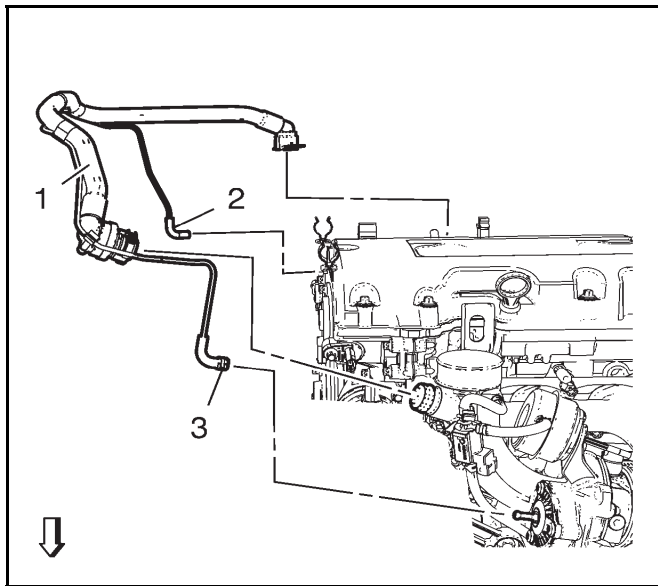

2191937

**Note:** Original PCV pipe with vacuum line attached removed from vehicle for illustrative purposes **ONLY**.

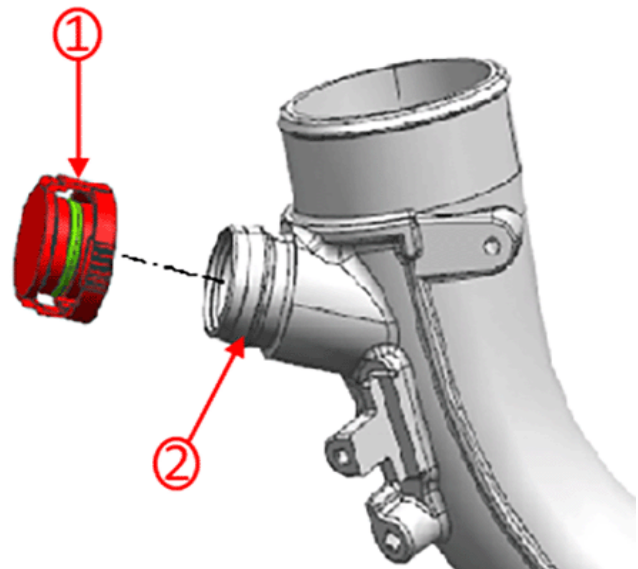

4377828

6. Install the block off plug (1) onto the turbocharger bypass port (2).



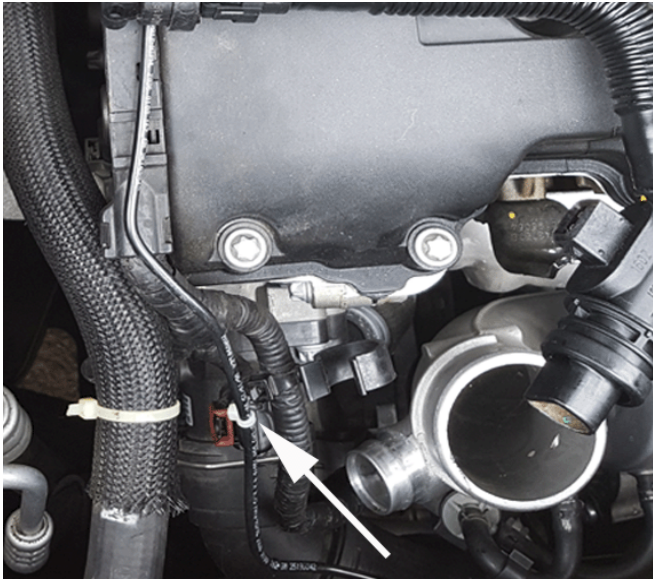

4855375

7. Using a tie strap, secure the vacuum line to the engine wiring harness.

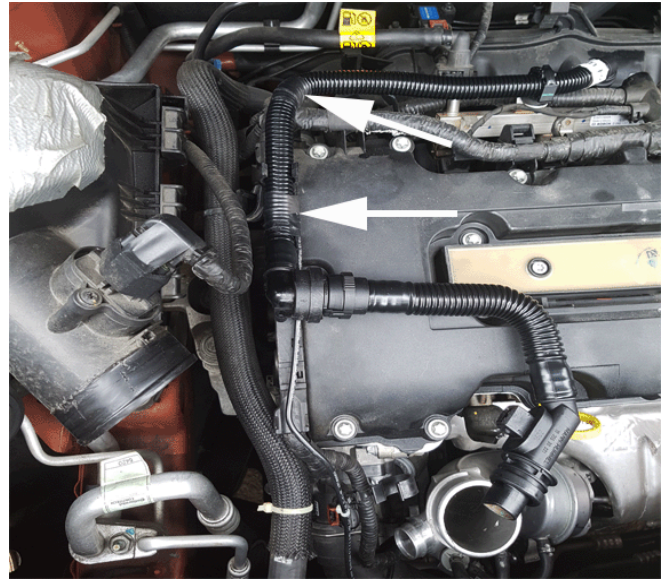

4855376

13. Using Woven Polyester Electrical Tape (PET), secure the vacuum line to the PCV pipe.

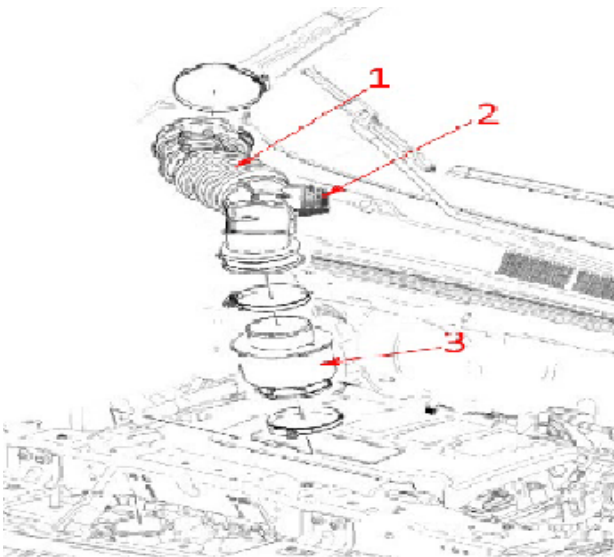

4418077

8. Install the new air cleaner outlet duct (1) and air resonator (3) assembly.
9. Using care, cut and remove the tape securing the vacuum line to the NEW PCV pipe.
10. Remove the vacuum line from the PCV pipe assembly.
11. Install the new PCV pipe assembly.
12. Install the PCV heater into air cleaner outlet duct (2).

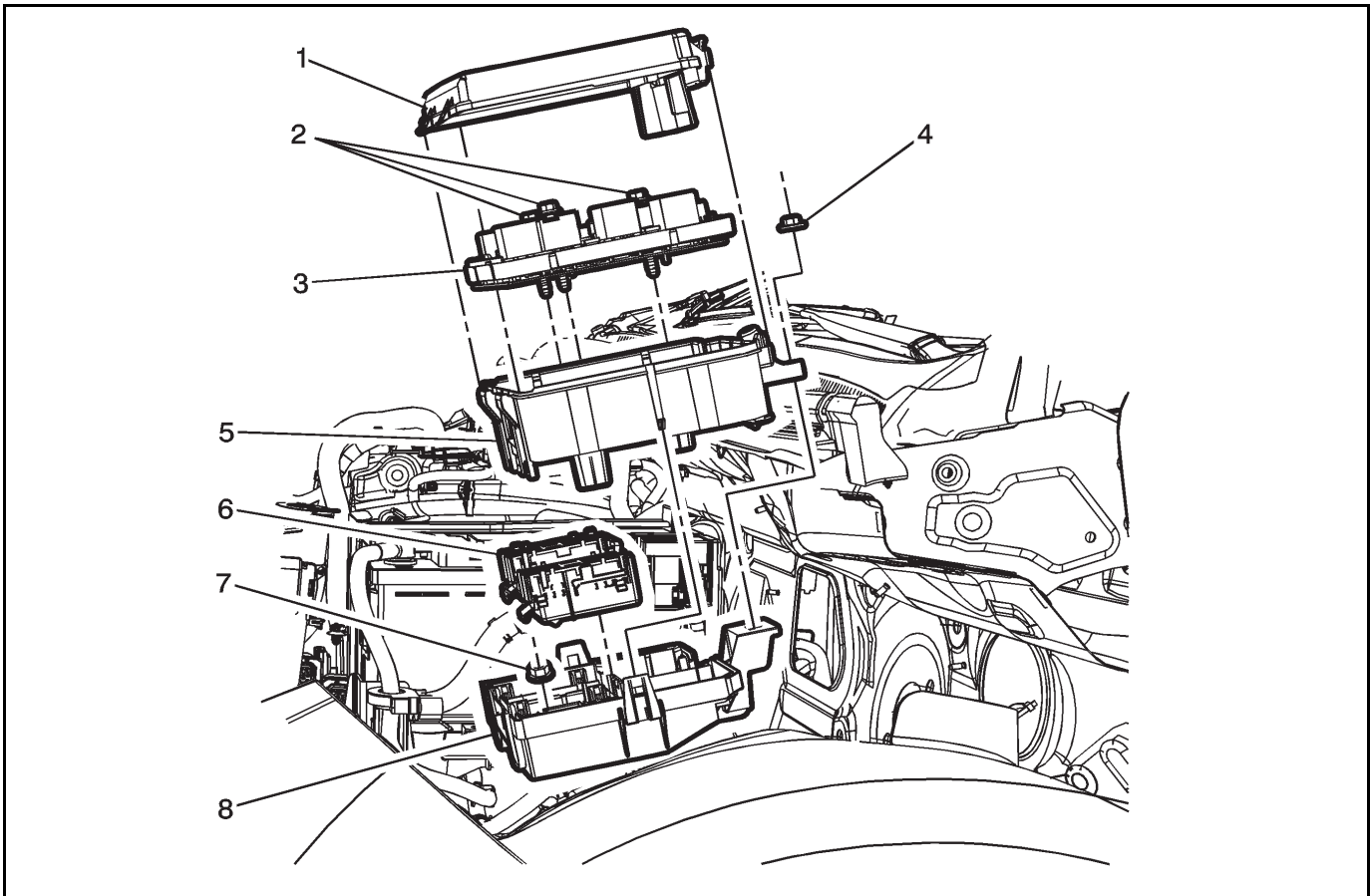

2760835

14. Remove the fuse block cover (1).
15. Remove the nut (4) that secures the upper fuse block to the body.
16. Loosen the three upper connector bolts (2).
17. Separate the upper (5) fuse block assembly from the fuse block base (8) by releasing the snap locks. Refer to *Front Compartment Fuse Block Replacement* in SI.
18. Route the PCV wiring harness under the battery tray.

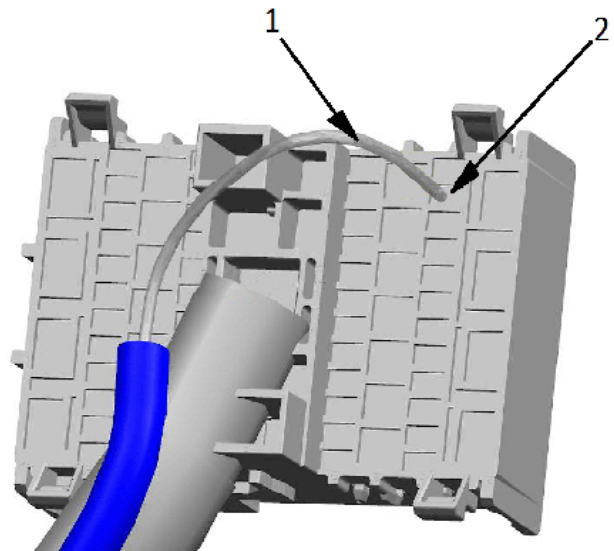

4377876

**19. For 2013-2016 model vehicles:**

- 19.1. Remove UEX\_X2 connector from the fuse block base.
- 19.2. Install PCV heater wiring harness terminal (1) into the J11 cavity (2).
- 19.3. Route the wiring harness between the battery and fuse block.



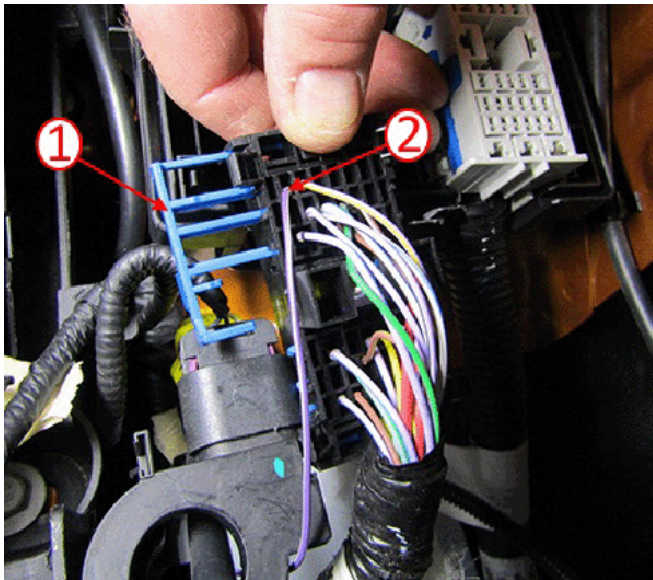

4598974

20. For 2017 model vehicles:

- 20.1. Remove the UEX\_X3 connector from the fuse block base.
- 20.2. Remove the X3 connector cover.
- 20.3. Remove connector lock (1).
- 20.4. Install PCV heater wiring harness terminal into the H6 cavity (2).

- 21. Using tie straps, fasten the PCV wiring harness to the connectors wiring harness at the white tape indicators.
- 22. Install the connector back onto the fuse block base.

**Important:** Only replace the fuse and install the labels on vehicles that have a 5 amp fuse. Some vehicles have the 10 amp fuse already installed and do not require replacement or the label.

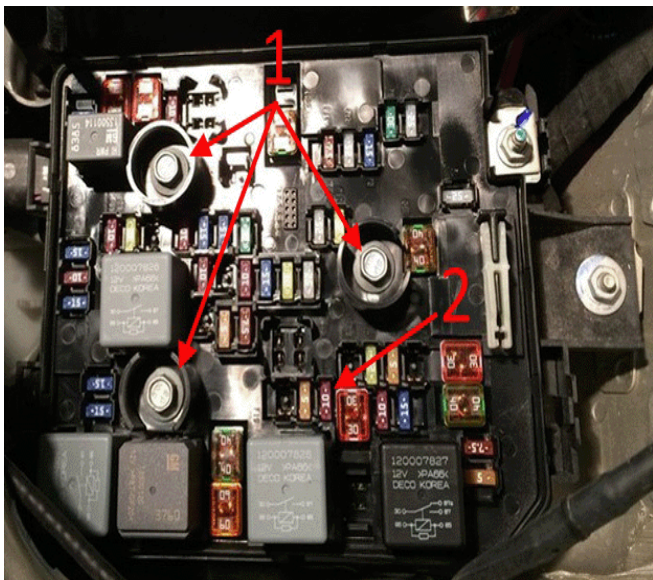

4379861

- 23. Position and snap the upper fuse block onto the base.

**Tighten**

Torque the bolts (1) to specifications. Refer to *Fastener Specifications* in SI.

- 24. If necessary, replace the 5 amp fuse with a 10 amp fuse into cavity F17 (2).
- 25. Install the front compartment fuse block cover.

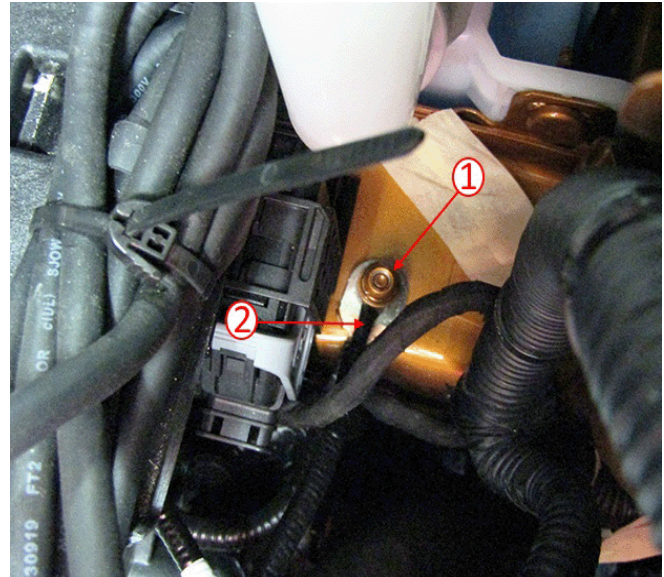

4605957

- 26. Install the PCV heater wiring harness ground wire (2) to ground G103 (1).

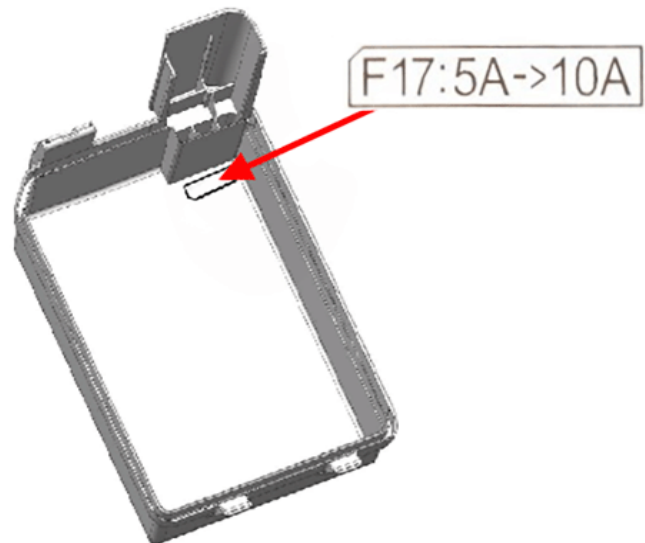

4379843

- 27. If necessary, install the UEC sticker onto the backside of the fuse block cover and in the owners manual under Engine Compartment Fuse Block.



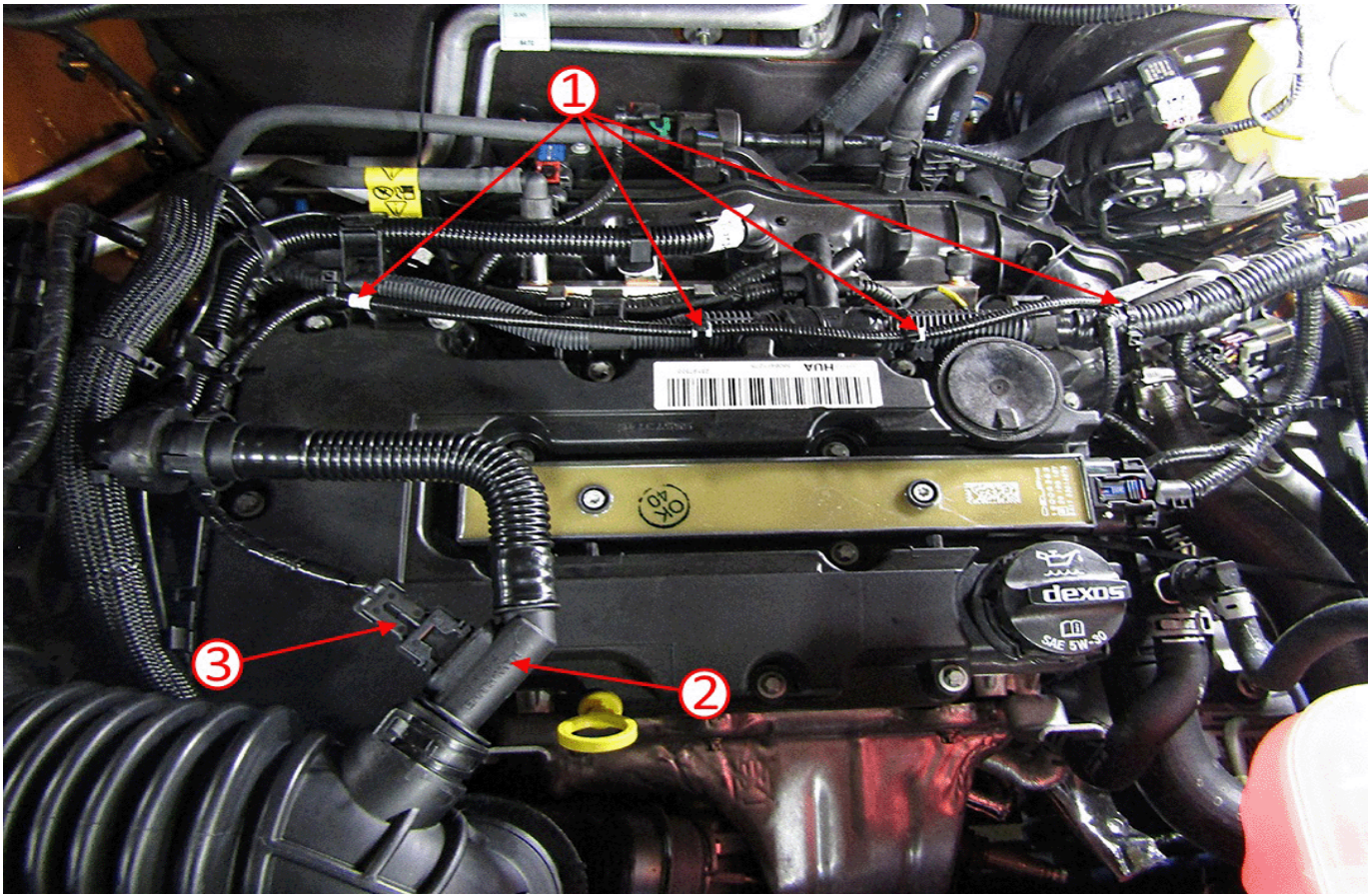

4609442

28. Route the PCV heater wiring harness across the engine wiring harness.
  29. Using the tie straps, fasten the wiring harness at the white marking points (1).
  30. Connect the electrical connector (3) to the PCV heater (2).
  31. Install the battery.
  32. Install engine cover.
- Important:** Do Not perform an oil change if the vehicle is returning for the CAC update and/or if the oil change was recently done.
- If the oil change was recently done, proceed to step 32.
  - If the oil change was not previously done, proceed with procedure.
33. If required, perform an oil change. Refer to *Engine Oil and Oil Filter Replacement* in SI.

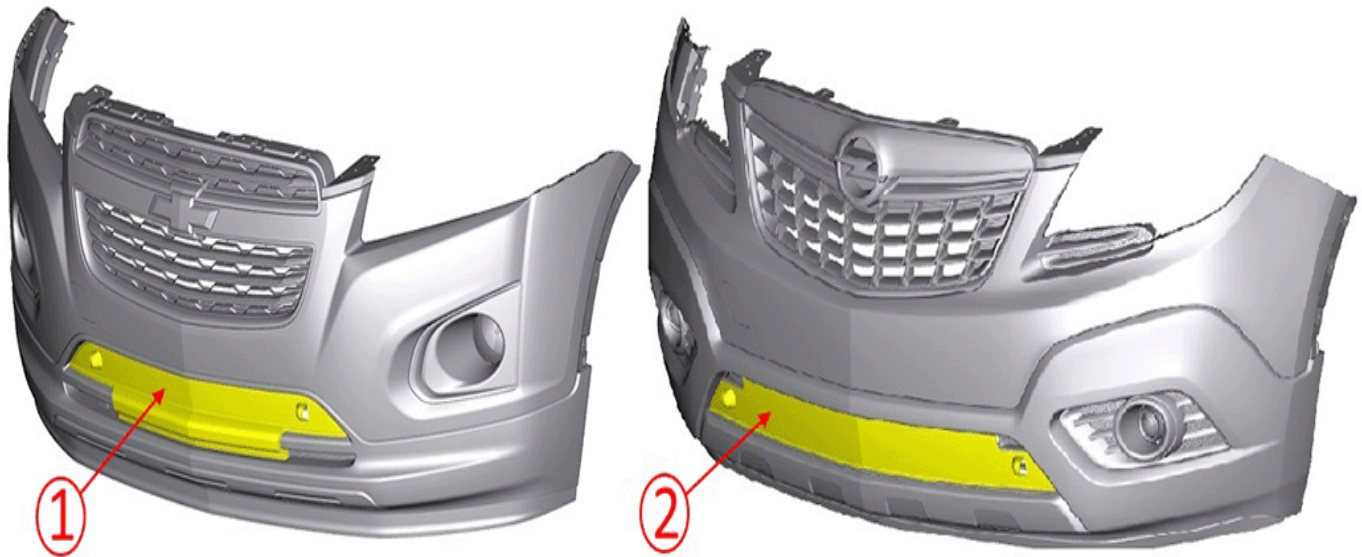

4639714

**Important:** If a fascia blocker was installed (1, 2) on the vehicle, it must be removed and discarded. A new fascia blocker will no longer need to be installed on the vehicle.

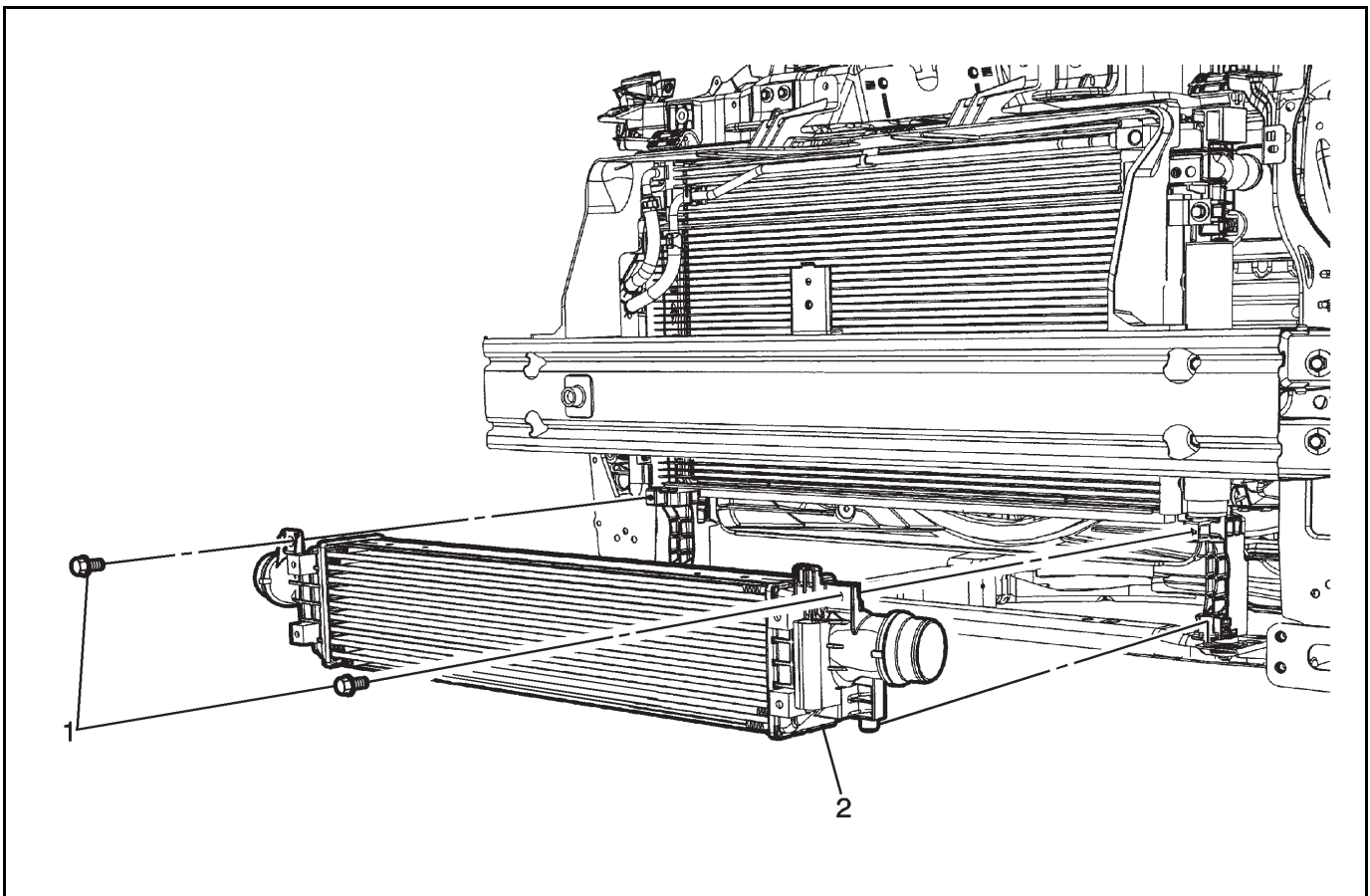

2851444

**Note:** Allow the Charge Air Cooler to warm up to room temperature so that any moisture can be drained.

34. If installed, remove and discard the fascia blocker.

35. Remove the CAC (2). Refer to *Charge Air Cooler Replacement* in SI.

36. Install modified CAC.



### Parts Information

Description	Model Year	Part Number	Qty
Kit, PCV Heater	2013-2016	25198125	1
Kit, PCV Heater	2017	25198126	1
Cooler, Charge Air	2013-2017 (Encore, Trax)	42574031 (VIN pos 1 = K)	1
	2013-2017 (Trax)	42582747 (VIN pos 1 = 3)	1
Filter, Oil	2013-2017	Refer to the Electronic Parts Catalog (EPC).	
Oil			

### Warranty Information

For vehicles repaired under the Powertrain coverage, use the following labor operation. Reference the Applicable Warranties section of Investigate Vehicle History (IVH) for coverage information.

Labor Operation	Description	Labor Time
4081358*	PCV Heater and Wiring Harness Installation	1.0 hr
Add	Charge Air Cooler Removal	1.0 hr
Add	Fascia Blocker Removal	0.2 hr
Add	Oil Change	0.3 hr
*This is a unique Labor Operation for Bulletin use only.		

Version	5
Modified	Dec. 23, 2016 - Added DTCs to the Condition and a Note to the Parts Information. Jan. 5, 2017 - Removed Fascia Blocker information. Jan. 18, 2017 - Added draining the CAC. Sept 7, 2017 - Added fascia blocker removal information and added CAC part numbers.

