

Service Update

17339 Incorrect Spare Wheel Assembly Installed



Reference Number: N172108840

Release Date: September 2017
Revision: 00

Attention: This service update includes vehicles in dealer inventory and customer vehicles that return to the dealership for any reason. This bulletin will expire at the end of the involved vehicle's New Vehicle Limited Warranty period.

| Make | Model | Model Year | | RPO | Description |
|-----------|----------|------------|------|-----|-------------|
| | | From | To | | |
| Buick | LaCrosse | 2017 | 2018 | QCL | Spare Tire |
| Chevrolet | Impala | 2017 | 2018 | | |

Involved vehicles are marked "open" on the Investigate Vehicle History screen in GM Global Warranty Management system. This site should always be checked to confirm vehicle involvement prior to beginning any required inspections and/or repairs.

| | |
|-------------------|---|
| Condition | Certain 2017-2018 model year Buick LaCrosse and Chevrolet Impala vehicles equipped with a spare tire (RPO QCL), may have a spare wheel assembly installed that will not have the correct lug pattern and either cannot be mounted to the vehicle, or may be difficult to mount which could lead to possible wheel detachment while driving. |
| Correction | Dealers are to inspect the spare wheel/tire, and if necessary, install the correct spare wheel. |

Parts

| Quantity | Part Name | Part No. |
|----------|-----------------------------|----------|
| 1 | Valve Stem | 274288 |
| 1 | Wheel-Spare Tire (Impala) | 13235015 |
| 1 | Wheel-Spare Tire (LaCrosse) | 84095141 |

Reminder: Parts may be removed from Retail Inventory Management (RIM). Dealers should review the affected parts to confirm RIM managed status. Parts may have quantity limiters in effect.

Warranty Information

| Labor Operation | Description | Labor Time | Trans. Type | Net Item |
|-----------------|---|------------|-------------|----------|
| 9103384 | Inspect Spare Wheel/Tire – No Further Action Required | 0.2 | ZFAT | N/A |
| 9103385 | Install Correct Spare Wheel (includes inspection) | 0.6 | ZFAT | N/A |

Service Procedure

Note: Perform a thorough visual inspection of the spare tire once unmounted. Inspect all internal and external surfaces for damage that may have occurred during the dismount process. After the remount and inflation process, inspect the outside surfaces of the tire for damage. If any damage is indicated, order and install a new spare tire. When ordering a new tire, use the tire sidewall information to order the CORRECT REPLACEMENT TIRE from your normal tire supplier.

Service Update

17339 Incorrect Spare Wheel Assembly



1. Open the rear compartment lid. Raise the spare tire cover (remove the spare tire if necessary).



4858273

Chevrolet Impala tire sticker number ends with 5015



4858274

Buick LaCrosse tire sticker number ends with 5141

2. Find the bar code label on the tread of the tire. Using the information on the bar code, verify the vehicle is equipped with the correct spare wheel/tire assembly.
 - If the correct wheel/tire assembly is installed in the vehicle, no further action is required.
 - If the incorrect wheel/tire is installed, replace the spare wheel (reuse the existing tire). Refer to *Tire Dismounting and Mounting* in SI.
3. Reinstall the rear compartment components as necessary.

Alternate Wheel Identification Procedure

If the spare tire bar code label is missing or not readable, use the following wheel identification graphics to determine if the correct wheel/tire assembly is installed in the vehicle.

Service Update

17339 Incorrect Spare Wheel Assembly

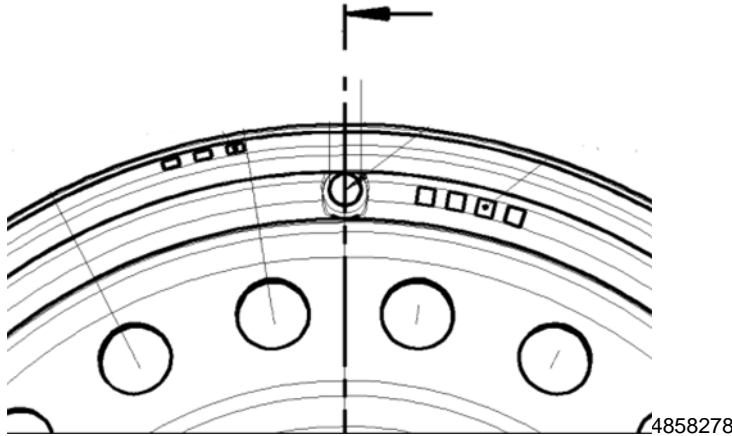

Chevrolet Impala valve stem located between holes in wheel

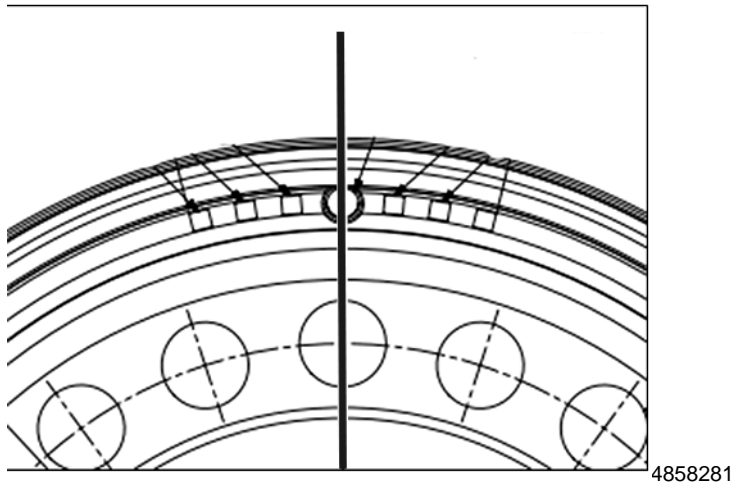

Buick LaCrosse valve stem aligned with hole in wheel

Dealer Responsibility

Whenever a vehicle subject to this service update enters your vehicle inventory, or is in your facility for service in the future, and the vehicle is still covered under the New Vehicle Limited Warranty, you must take the steps necessary to be sure the service update correction has been made before selling or releasing the vehicle.

All new, used, GM Certified Used, courtesy transportation vehicles, dealer shuttle vehicles, etc. in dealers' possession and subject to this bulletin must be held and inspected/repared per the service procedure of this bulletin before customers take possession of these vehicles. Involved vehicles must be held and not delivered to customers, dealer-traded, released to auction, used for demonstration, or any other purpose.

All GM Certified Used vehicles currently in the dealers' inventory within the Certified Pre-Owned Inventory System (CPOIS) will be de-certified and must be held and remedied per the service procedure in this bulletin. Upon submitting an accepted/paid warranty transaction in the Global Warranty Management (GWM) system, the vehicle can be re-certified for sale within the CPOIS system, or once again be used in the CTP program.

GM bulletins are intended for use by professional technicians, NOT a "do-it-yourselfer". They are written to inform these technicians of conditions that may occur on some vehicles, or to provide information that could assist in the proper service of a vehicle. Properly trained technicians have the tools, equipment, safety instructions, and know-how to do a job properly and safely. If a condition is described, **DO NOT** assume that the bulletin applies to your vehicle, or that your vehicle will have that condition. See your dealer for information on whether your vehicle may benefit from the information.



**We Support
Voluntary Technician
Certification**

GLOBAL SAFETY FIELD INVESTIGATIONS
DCS4572
URGENT - DISTRIBUTE IMMEDIATELY

Date: September 27, 2017

Subject: 17339 - Service Update
Incorrect Spare Wheel Assembly Installed

Models: 2017-2018 Buick LaCrosse
2017-2018 Chevrolet Impala
Equipped with Spare Tire (RPO QCL)

To: All General Motors Dealers

General Motors is releasing Service Update 17339 today. The total number of U.S. vehicles involved is 52,465. Please see the attached bulletin for details.

Global Warranty Management (GWM)

The Investigate Vehicle History (IVH) screen in the GWM system will be updated September 27, 2017. A list of involved vehicles in dealer new inventory is attached to this message. Please hold all warranty transactions until the VIN appears in IVH.

END OF MESSAGE
GLOBAL SAFETY FIELD INVESTIGATIONS