

> Constellation
> Heritage
> 4700 Models

> 4800 Models
> 4900 Models
> 5700 Models

> 5900 Models
> 6900 Models

**Western Star
Service Bulletin**

Description of Revisions: *This bulletin replaces the version dated May 2017. Instructions for removing the fuel level sender float have been updated.*

General Information

A new improved fuel-level sending unit, manufactured by KUS, is available for retrofitting the fuel-level sending unit on all Western Star vehicles. No parameter changes are required. A new connector is required for the retrofit. See **Fig. 1**.

Refer to **Fig. 2** for this procedure.



10/27/2016

f470692

Fig. 1, New Connector Pigtail

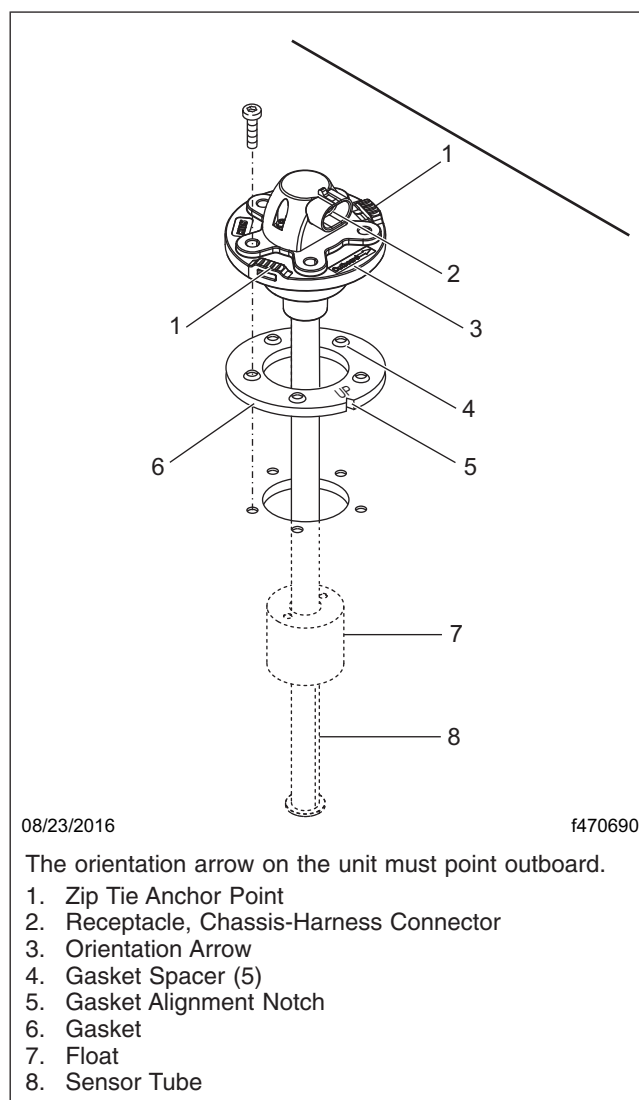

08/23/2016

f470690

The orientation arrow on the unit must point outboard.

1. Zip Tie Anchor Point
2. Receptacle, Chassis-Harness Connector
3. Orientation Arrow
4. Gasket Spacer (5)
5. Gasket Alignment Notch
6. Gasket
7. Float
8. Sensor Tube

Fig. 2, Fuel-Level Sending Unit

Replacement Procedure

1. Park the vehicle on a level surface, shut down the engine, and set the parking brakes. Chock the tires.
2. If needed, remove the side fairing.
3. Disconnect the fuel-level sending unit harness connector.
4. Remove the five fasteners from the flange of the fuel-level sending unit and discard them.
5. Remove and discard the P-clamp from the chassis harness.
6. Lift the fuel-level sending unit out of the hole in the tank.
7. Install the gasket on the new KUS fuel-level sending unit, making sure the "UP" side of the gasket is against the unit head, and the alignment notch on the sender aligns with notch on the gasket. See [Fig. 3](#).

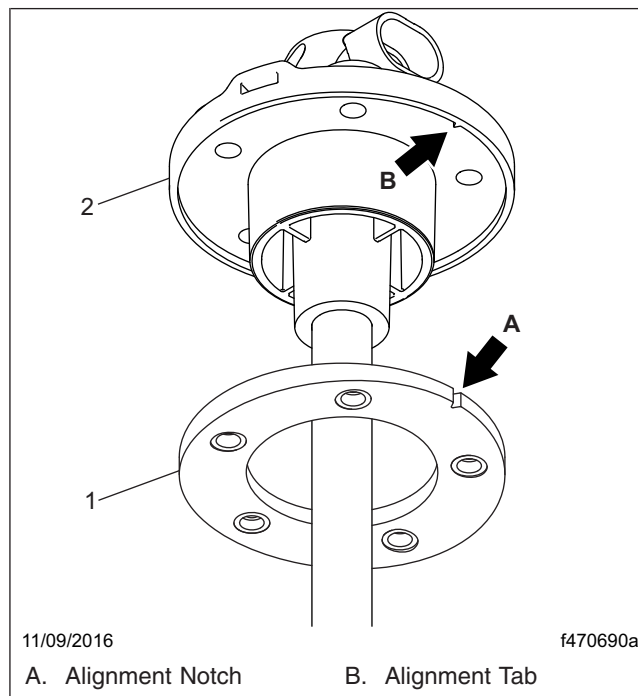

Fig. 3, Installing the Gasket

NOTICE

There is only one correct way to install the fuel-level sending unit. The orientation arrow on the top of the sending unit must point outboard. See [Fig. 2](#), item 3. Incorrect installation will damage the unit, and possibly the fuel tank, leading to inaccurate fuel-level readings and fuel leaks.

NOTE: If it is necessary to remove the KUS unit once it is in the tank, it may be necessary to lift the float to the top of the shaft in order to achieve sufficient clearance to remove the unit. A coat hanger or aluminum welding rod shaped into a hook can be used for this purpose and is the preferred method. Bend a coat hanger or aluminum welding rod 90 degrees and form a hook at the end 1-inch

> Constellation
> Heritage
> 4700 Models

> 4800 Models
> 4900 Models
> 5700 Models

> 5900 Models
> 6900 Models

long and 1-inch wide as shown in **Fig. 4**. See **Fig. 5** for an example of the hook around the float. A magnetic retrieval tool can also be used. See **Fig. 6** for an example. It may take several attempts to attach the magnet to the float. Also, if there is limited access, it may be necessary to adjust the cab height to its maximum.

8. Position the fuel-level sending unit and gasket in the hole in the tank, making sure that the orientation arrow on the top of the sending unit is pointing outboard. See **Fig. 7**.

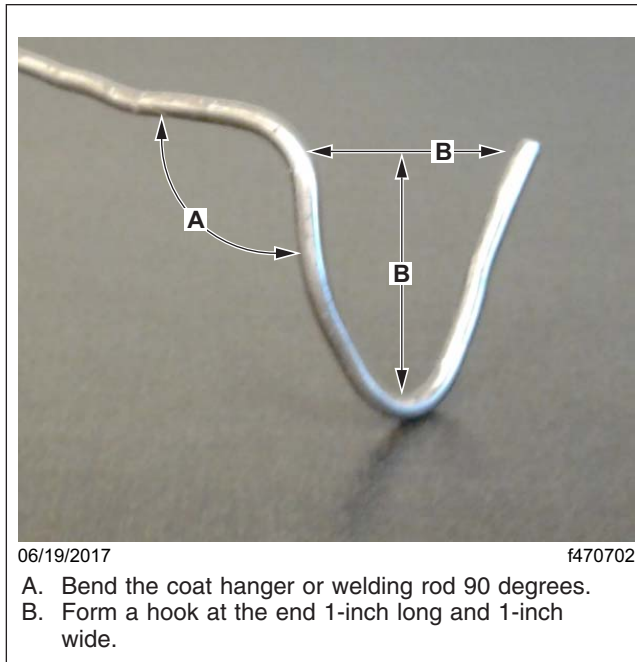

Fig. 4, Making the Hook Tool



Fig. 5, Lifting the Float

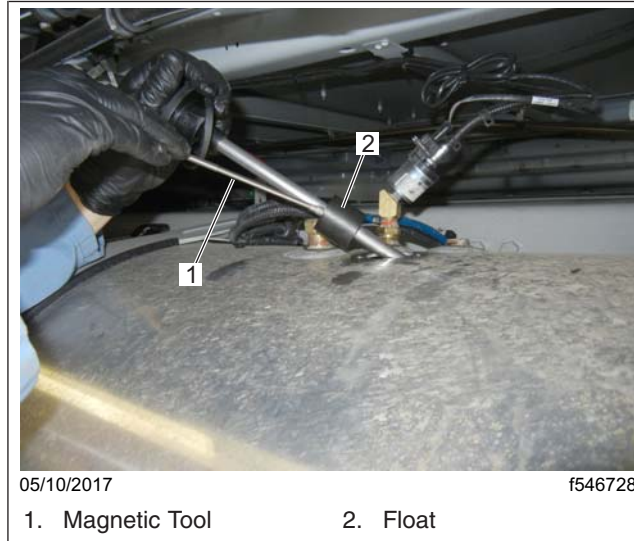

Fig. 6, Using a Magnetic Tool to Lift the Float

NOTICE

Tapping the screw holes in a new tank requires more torque than the recommended final tightening torque. The self-tapping fasteners will completely tap the tank wall before they are seated. Failure to follow the proper procedure will damage the tank and cause leaks.

9. Install new fasteners.

If installing the fuel-level sending unit in a new tank, start all five of the self tapping fasteners through the tank wall before applying the final tightening torque.

If installing the fuel-level sending unit in a used tank, start all five self tapping screws until contact is made with the top plate of the fuel-level sending unit. Do not tighten the screws at this time.

NOTICE

Do not over tighten the fasteners. Exceeding the recommended torque specification can strip out the holes in the tank, requiring tank repair or replacement.

10. Using the tightening sequence shown in [Fig. 8](#), and even progression to distribute the torque evenly around the fuel-level sending unit, sequentially tighten the screws 15 to 25 lbf·in (160 to 212 N·cm).

NOTE: When attaching the new pigtail, each wire can be connected to either wire of the chassis harness.

11. Cut the old connector from the fuel-level sending unit harness, and splice the new pigtail to the chassis harness and the sender receptacle. See [Fig. 9](#).

Fuel Level Sending Unit Retrofit

54-64

> Constellation
> Heritage
> 4700 Models

> 4800 Models
> 4900 Models
> 5700 Models

> 5900 Models
> 6900 Models

Western Star Service Bulletin

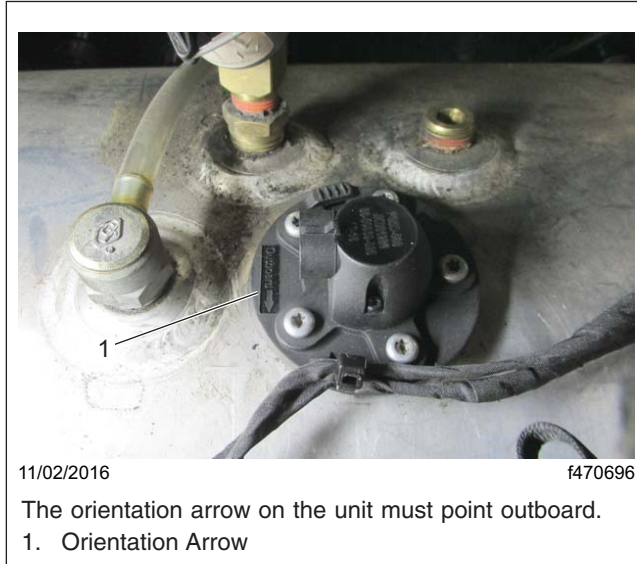

Fig. 7, Sending Unit Orientation

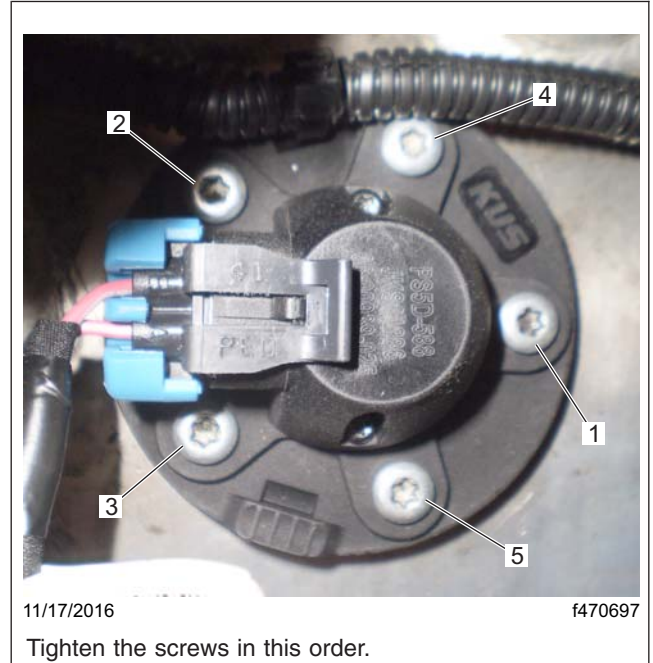

Fig. 8, Tightening Sequence

12. Connect the harness to the fuel-level sending unit.

13. Secure the harnesses to the sender with a zip-tie. See [Fig. 10](#). Do not use a P-Clamp.



Fig. 9, New Pigtail Installation

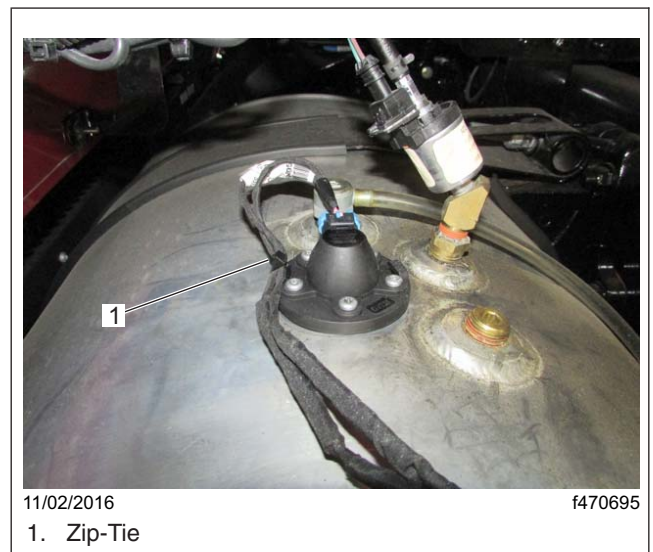

Fig. 10, Harness Connected and Secured

Parts

Parts are available through the PDC.

Fuel Tanks with Associated Senders and Gaskets					
Tank	Medallion Angular Sender	SSI Sender (focus tube)	Old Gasket	KUS Gasket *	KUS Linear Sender
22-inch Cylindrical	A22-68359-003	N/A	22-27156-000	06-95042-000	66-00939-022
23-inch Cylindrical	A22-68359-000	A22-68419-023 (A22-68428-023)		06-94788-000	66-00939-023
25-inch Cylindrical	A22-68359-001	A22-68419-025 (A22-68428-025)		06-95042-000	66-00939-025
26-inch Cylindrical	A22-68359-002	N/A		06-95042-000	66-00939-026
312 mm Rectangular	A22-68359-010	N/A	C1TF 9276 C	06-95042-000	66-00939-312
378 mm Rectangular	A22-68359-011	N/A			66-00939-378
462 mm Rectangular	A22-68359-012	N/A			66-00939-462
407 mm Between-Rail Steel	A22-66426-002	N/A			66-00939-407
Adaptor Harness, Service Only. Converts Medallion to KUS on trucks in the field.					A66-06600-000

* Reference only. KUS sensors include gaskets.

Table 1, Fuel Tanks with Associated Senders and Gaskets

Warranty

This bulletin is informational only. Warranty does not apply.